



Analysis of kVA Savings with PowerPlus under Certain Conditions

Robert N Guenther, Jr



VP- Product Development and Engineering

IEEE Fellow

Introduction

PowerPlus, our ESP switchmode power supply, was designed solely for the purpose of increasing average power into the precipitator; however, some customers have reported energy savings in the form of reduced kVA in addition to increased power into their fields. They have provided us with operating data demonstrating lower opacity readings and lower energy use with PowerPlus. Despite this documentation, this concept continues to be a source of confusion for some. This paper will clarify how PowerPlus can require lower kVA and still provide more power to the precipitator fields.

Table 1 compares the operating parameters of a standard transformer/rectifier (T/R) set to PowerPlus and calculates the resultant kVA savings:

Table 1
T/R and PowerPlus Comparison
(for 55 kV, 1000 ma, 60 Hz Power Supply vs. 70 kV, 1000ma SMPS)

Item	Conventional 60 Hz	SMPS
ESP Capacitance (nF)	100	100
V ac	480	480
I ac	196.00	86.80
kV DC	55.00	61.50
ma DC	1000	1000
kW DC	55.00	61.50
kW increase	***	11.82%
kW losses	3.5	3.8
kWin	58.5	65.3
PF	.63	.94
kVA in	92.9	69.5
kVA decrease	***	25.2%
kVA saved	***	23.4
Annual Revenue Per SMPS Unit		
Installed: (based on 365 days per year)		
at 0.04 \$/kVA-hr	at 0.05 \$/kVA-hr	at 0.06 \$/kVA-hr
\$8,199	\$10,249	\$12,299

Analysis

PowerPlus puts more kW into the ESP than a T/R, and the losses are slightly higher per unit under these conditions. It should also be noted that the standard T/R system has 3rd order harmonics, while the PowerPlus unit has harmonics starting at the 5th order. This information, combined with the higher I_{ac} currents for the standard T/R system, leads to the conclusion that the feeder cable and transformer losses for the traditional T/R system are higher than those for the PowerPlus. The net result is that the total system losses are slightly higher for the traditional SCR-CLR-T/R than for the PowerPlus. For the purposes of this paper, they will be assumed to be equal.

Fundamentally, as long as PowerPlus is putting more kW into the ESP, more kW(s) are required from the generating station. This is correct and adheres to fundamental equations for electrical power. It is also correct to assert that kVA and output power are not equivalent. kVA, also called apparent power, is the vector sum of the reactive power and real power. Reactive power is produced by the inductive or capacitive elements in a system. It is the much greater reactive power of the T/R that accounts for the kVA difference between it and PowerPlus. This is a consequence of the much lower power factor of the traditional SCR-CLR-T/R system. There are three electrical reasons for this:

1. The lagging current due to the 50% system inductive reactance of the CLR and transformer (this is the inductive element).
2. Due to the capacitive nature of the ESP load and the distorted waveforms produced by the SCR operation, the rms value of the I_{ac} is much higher than the average current (mADC reflected to the primary side). This high rms/DC ratio raises the kVA/kW_{in} ratio.
3. SCRs operate by delaying the time at which they turn-on following the zero crossing of the incoming voltage waveform. This phase delay in the turn-on of current makes the system appear to be even more inductive and pushes the power factor even lower.

The end result is that for a standard T/R operating at rated kVDC and mADC, the power factor is approximately 0.63. The fact is that this low power factor condition gets worse for other operating conditions a standard TR system is likely to encounter. Refer to Table 2 on the next page for additional operating data comparison and analysis:

Table 2. T/R and PowerPlus comparison at various loads

Comparison of STD SCR-T/R with PowerPlus 1- STD has 50% X with compensated primary drop 2- STD has I _{ff} = 1.2, V _{ff} = 1.188 3- For equivalent mA and esp performance, kVdc (P+) = SQ.ROOT(kVdc(STD)*kVpeak(STD)) 4- STD analysis done on Pspice 5- STD unit is 55kVdc, 1000 mAdc; PowerPlus is 70 kVdc, 1000 mAdc 6- esp capacitance estimated at 100 nF 7- STD losses are 3.5 kW at 55kVdc, 1000 mAdc 8- PowerPlus losses are 4.0 kW at 70 kVdc, 1000 mAdc 9-PowerPlus lac based on measurements made during prototype testing														
	STD	PowerPlus				STD	PowerPlus							
	SCR-T/R					SCR-T/R								
Standard (STD) unit at rated kVdc, rated mAdc				Standard (STD) unit at rated kVdc, 50% rated mAdc										
V _{ac}	480	480		V _{ac}	480	480								
mAdc	1000	1000		mAdc	500	500								
kVdc	55	61.47		kVdc	55.2	60.08								
K _v peak	68.7			K _v peak	65.4									
kW _{esp}	55.0	61.5		kW _{esp}	27.6	30.0								
kW loss	3.5	3.7		kW loss	2.0	2.4								
kW _{in}	58.5	65.2		kW _{in}	29.6	32.4								
PF	0.62	0.94		PF	0.55	0.93								
I _{ac}	196	83.15		I _{ac}	112	42.13								
kVA _{in}	94.08	69.13		kVA _{in}	53.76	35.03								
kVA _{save}		24.95		kVA _{save}		18.73								
Standard (STD) unit at 67% rated kVdc, rated mAdc				Standard (STD) unit at 67% rated kVdc, 50% rated mAdc										
V _{ac}	480	480		V _{ac}	480	480								
mAdc	1000	1000		mAdc	500	500								
kVdc	37.2	43.98		kVdc	37	41.88								
K _v peak	52			K _v peak	47.4									
kW _{esp}	37.2	44.0		kW _{esp}	18.5	20.9								
kW loss	3.3	3.3		kW loss	1.8	2.0								
kW _{in}	40.5	47.3		kW _{in}	20.3	23.0								
PF	0.41	0.93		PF	0.37	0.90								
I _{ac}	205	61.02		I _{ac}	114	30.55								
kVA _{in}	98.4	50.73		kVA _{in}	54.72	25.40								
kVA _{save}		47.67		kVA _{save}		29.32								

An ESP power supply rarely operates at rated kVDC and mADC. The inlet field tends to run fairly high kVDC with suppressed mADC levels. As the gas moves through subsequent fields towards the outlet of the ESP, the kVDC levels tend to drop while running at or near mADC current limit levels. In Table 2, the analysis of units running at 67% kVDC and 100% mADC is typical of units several fields in from the ESP inlet.

For this example, the standard T/R delivers 37.2 kW to the ESP versus 44.0 kW for the PowerPlus. For the standard T/R system (now down to a power factor of .41), the input kVA is 98.4 while that for the PowerPlus is only 50.73 kVA. **A huge reduction of 47.67 kVA is obtained.**

It takes more kW into the PowerPlus to get more kW into the ESP. We have also seen that even with somewhat more power into the ESP, a large reduction in the kVA required from the feeder system is obtained. What happens to this kVA that is no longer needed? Are there any benefits to the power plant? Let's start by looking at the following simplified diagram:

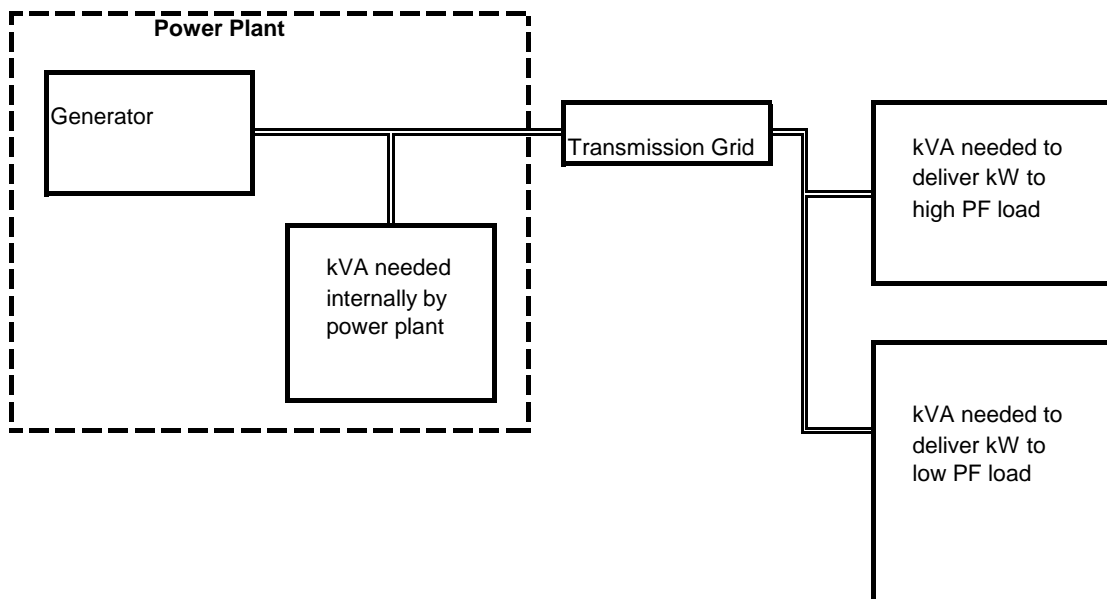

A power plant generator creates a voltage and supplies current as demanded by the loads connected to it. This generated voltage multiplied by load current x 1.73 equals Volt-amperes (or **kVA** if divided by 1000). The loads can be internal to the plant or external at various points on the transmission grid. If the kVA load in the power plant is reduced, then more amperes are available for loads connected to the grid.

Electricity usage is expressed in kW-hr, which is the unit of measure for the purchase and sale of electric power. Some users have good power factor while some have lower power factor. Lower power factor users pay a higher fee per kW-hr, or they must invest in equipment to improve their power factor. The reality is that kW-hrs are bought and purchased based on the loads connected to the grid meeting a required level of power factor. The VARs (reactive component of kVA) level required to supply the kW demand is essentially an “overhead factor” that needs to be absorbed in establishing the price per kW-hr. The end result is that when less kVA is needed in a power plant, there will be more amperes available to customers connected to the grid (holding system voltage constant means that more kVA translates into more Amperes). If the user loads demand more amperes, and therefore more kW, then more kVA is needed. The additional kW-hrs consumed translate into greater revenue for the power plant.

We have clarified that it takes more kW from the power plant to get more kW into the ESP and explained how PowerPlus reduces the amount of generated kVA required from the Power Plant. Are these improvements just theoretical, or can they be achieved in reality? The following charts, provided by one of our largest customers, show that by using PowerPlus, they have actually achieved all of the following:

1. More kW into the ESP
2. Less kVA required from the Power Plant
3. Reduced opacity at the outlet of the ESP

Performance History at Full Load

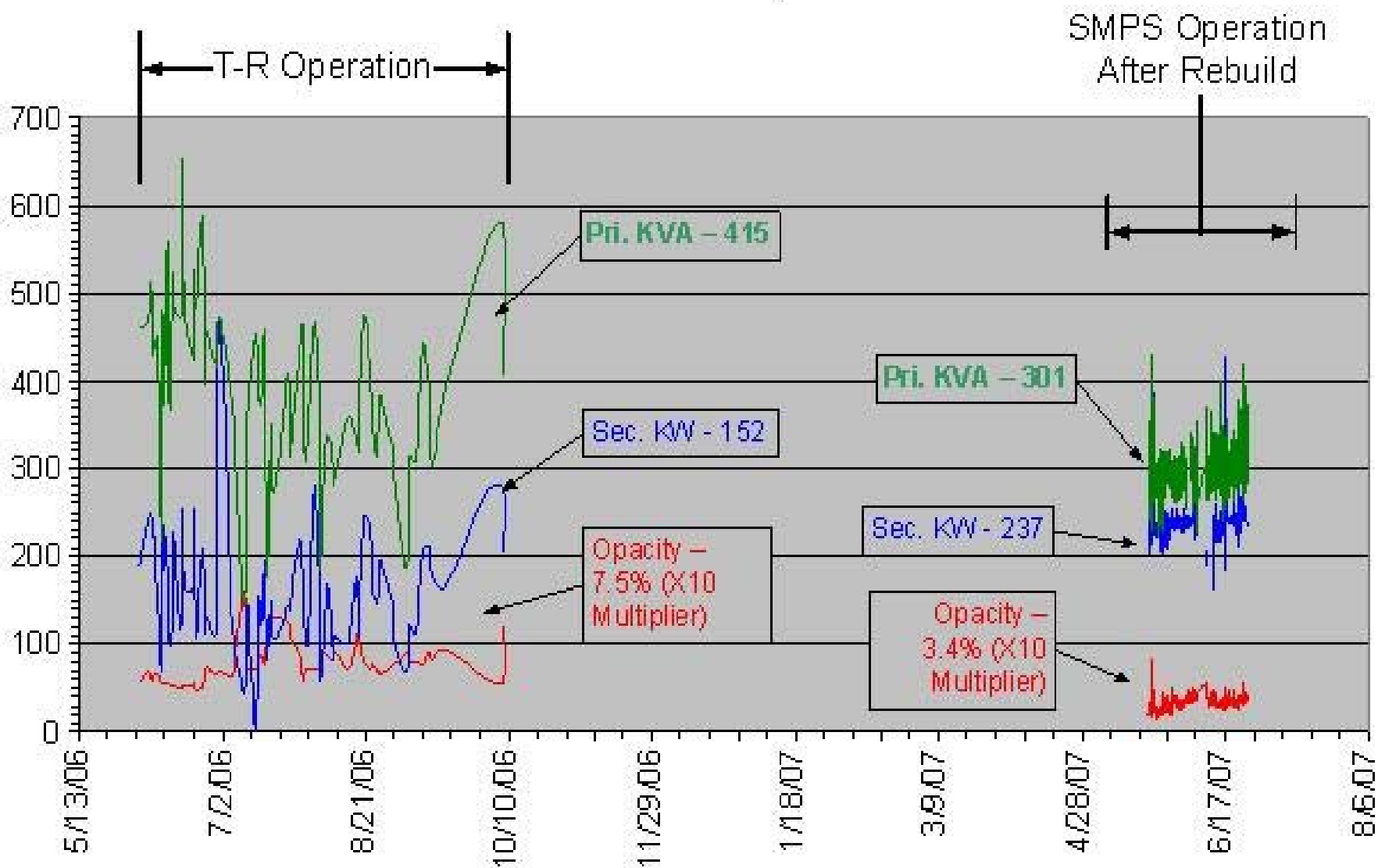

— T-R Op X10
 — T-R KW
 — T-R KVA
 — SMPS Op X10
 — SMPS KW
 — SMPS KVA

Performance History at Full Load

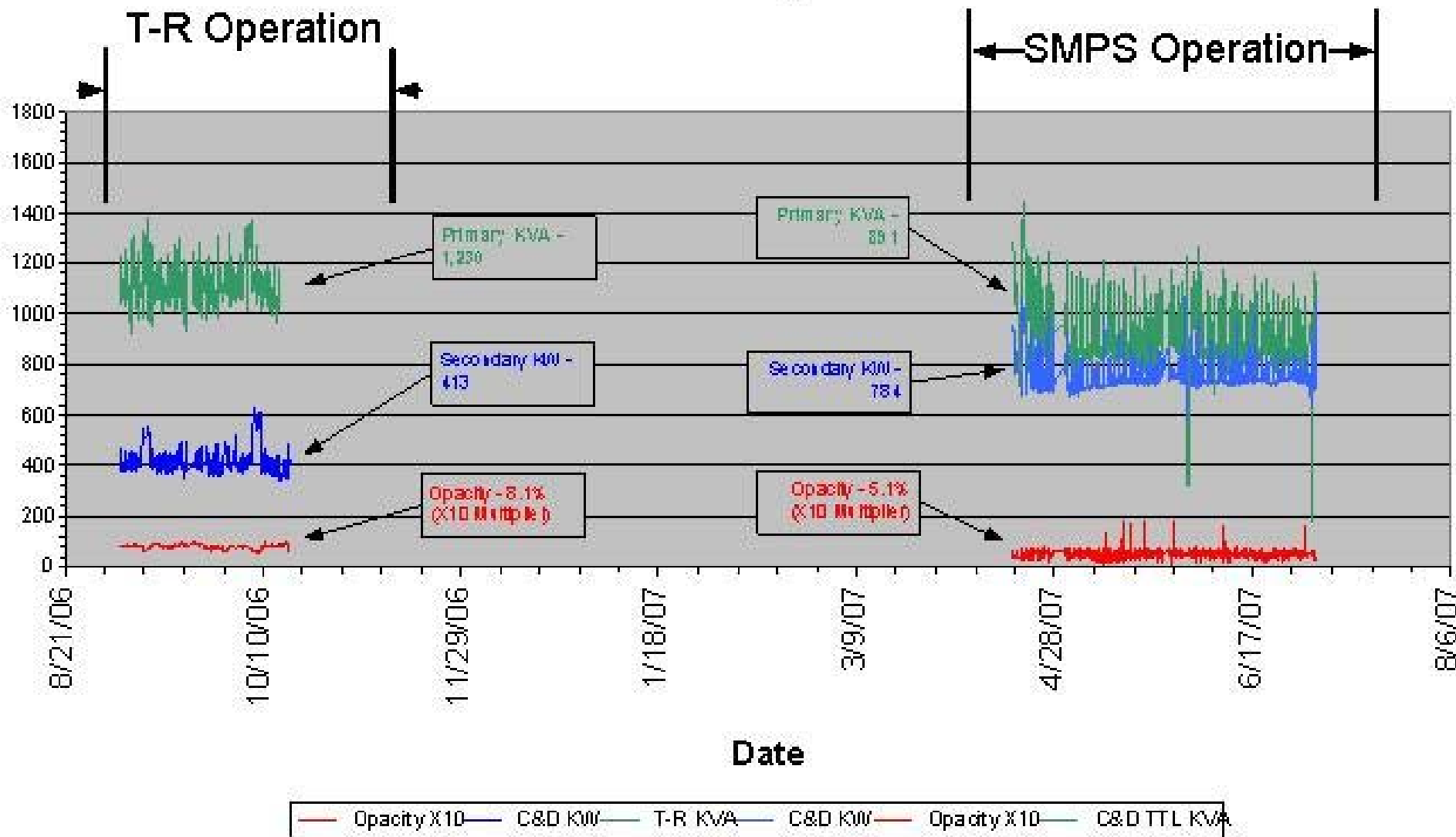

Conclusion

Although this document has focused on clarifying terminology and explaining how using less kVA in a power plant can lead to increased revenue, it must be stated that the primary reason for choosing PowerPlus is for improved particulate collection.

In the end, there are three reasons to use a PowerPlus unit on an ESP:

1. **Flexibility of operation:** The circuit topology and high frequency operation allow higher kVDC operating levels when the dust resistivity is low to moderate. For moderate to high levels, the fast and fine resolution IE mode far surpassed the control available with a standard T/R system.
2. **Higher kW into the ESP for less kVA from the plant:** The circuit topology allows the above collection improvements to be obtained without upgrading the ESP feeder system. At the same time, the power plant then has the opportunity to generate additional revenue with the kVA that has been made available to loads connected to the grid.
3. **Integrated Package:** Because the PowerPlus is a factory wired system (not just a T/R, but equivalent to a T/R + CLR + SCR control), it offers a lower installed cost with less likelihood of errors in field due to inter-wired connections required for standard T/R installations. The use of common platform parts throughout the product line enables faster delivery, more efficient spare parts management (including HV tanks), and better trained field support.