

2

1

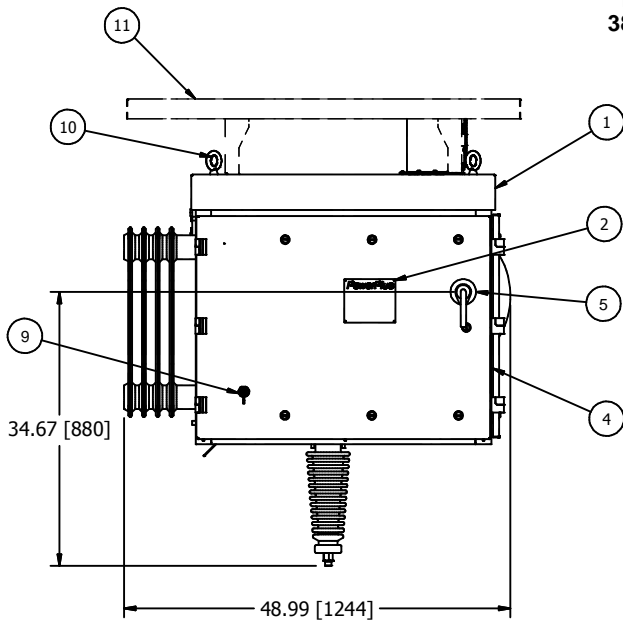

**POWERPLUS SERIES 7  
380VAC, 56kW, 83kV UNIT**



FRONT VIEW

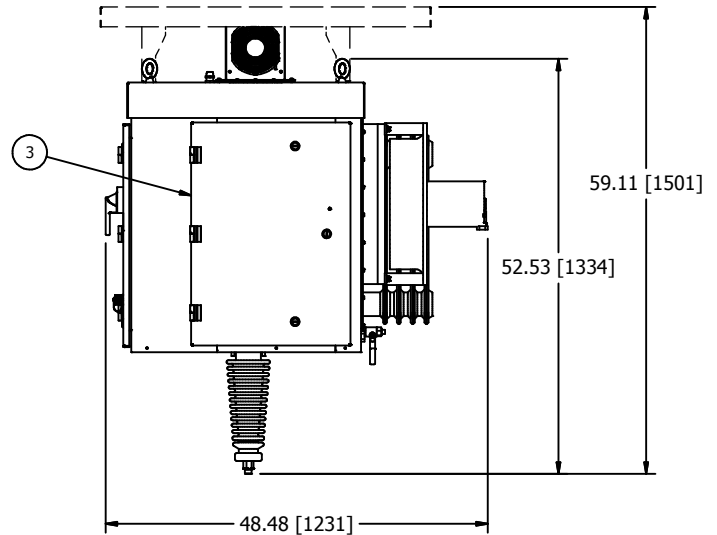

SIDE VIEW

- ① POWERPLUS UNIT
- ② RATINGS NAMEPLATE, ALUMINUM PHOTO ETCHED.
- ③ POWER ELECTRONICS SECTION WITH HINGED DOOR. ALLOW 19" [483] OF CLEARANCE FROM THIS FACE FOR DOOR SWING.
- ④ SWITCHGEAR AND CONTROL SECTION WITH HINGED DOOR. ALLOW 37" [940] OF CLEARANCE FROM THIS FACE FOR DOOR SWING.
- ⑤ INPUT CIRCUIT BREAKER SWITCH HANDLE WITH INTERLOCK PROVISION INSIDE. FOR ACCEPTABLE INTERLOCKS SEE DWG C140616.
- ⑥ 1" [25.4] DIA. CONDUIT HOLE FOR 120V CONTROL WIRING.
- ⑦ 1/2" [12.7] DIA. CONDUIT HOLE FOR LOW VOLTAGE COMMUNICATION AND OPTIONAL TRANSDUCER CONDUIT.
- ⑧ 2" [51] DIA. CONDUIT HOLE FOR 3 PHASE POWER AND GROUND.
- ⑨ WEATHER TIGHT, RJ45 CONNECTOR FOR NWL HMI CONNECTION.
- ⑩ LIFTING EYES (4 PLACES).
- ⑪ OPTIONAL SUN SHIELD MUST BE SHIPPED SEPARATELY AND INSTALL IN THE FIELD.

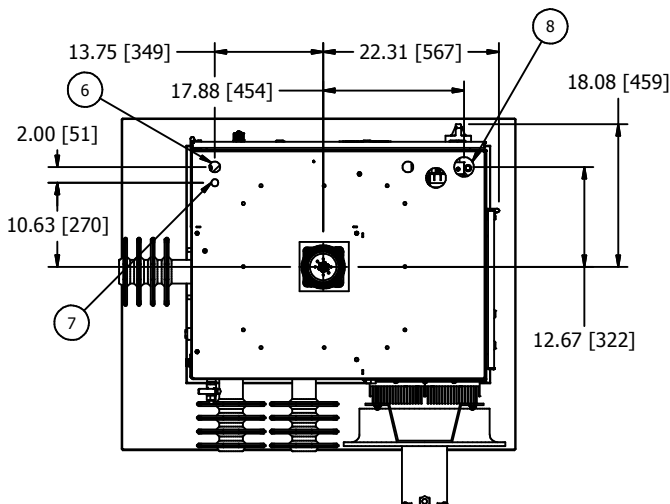

BOTTOM VIEW

**ELECTRICAL SPECIFICATIONS**

kW	kVA	Input Voltage 3Ø, 50/60 Hz, ±10%	Output Current mADC	Output Voltage kVDC	Rated Input Current Amps	Circuit Breaker Rating Amps	Losses kW
56	63	380	675	83	95	150	4.5

Min. Ambient Temp.	Max. Avg. Ambient Temp. (24 hr)	Max. Ambient Temp.
-20°C	40°C	50°C for up to 4 hours over a 24 hour period

EXPORT CRATE DIMENSIONS: 58 (1473mm)L x 58 (1473mm)W x 94 (2388mm)H.\*  
 EXPORT CRATE WEIGHT: 1700lbs (771kg).\*  
 MAXIMUM FLOOR LOADING: 305lbs/sq.ft (1489kgs/sq.m).\*  
 DIELECTRIC FLUID VOLUME: 29gal (110L).  
 FINISH: ENAMEL, ASA 61, APPROX. RAL 7042.  
 TANK AND CONTROL ENCLOSURE RATED NEMA 4/IP56.

\*DIMENSIONS AND WEIGHT ARE BASED ON POWERPLUS MOUNTED ON A SQUARE SIDE EXIT GROUND SWITCH.

DATA SHEET: 380\_56\_83\_S7

REVISION DATE: 01/29/18

APPROVED BY: RJK

ALL DIMENSIONS IN INCHES [mm]