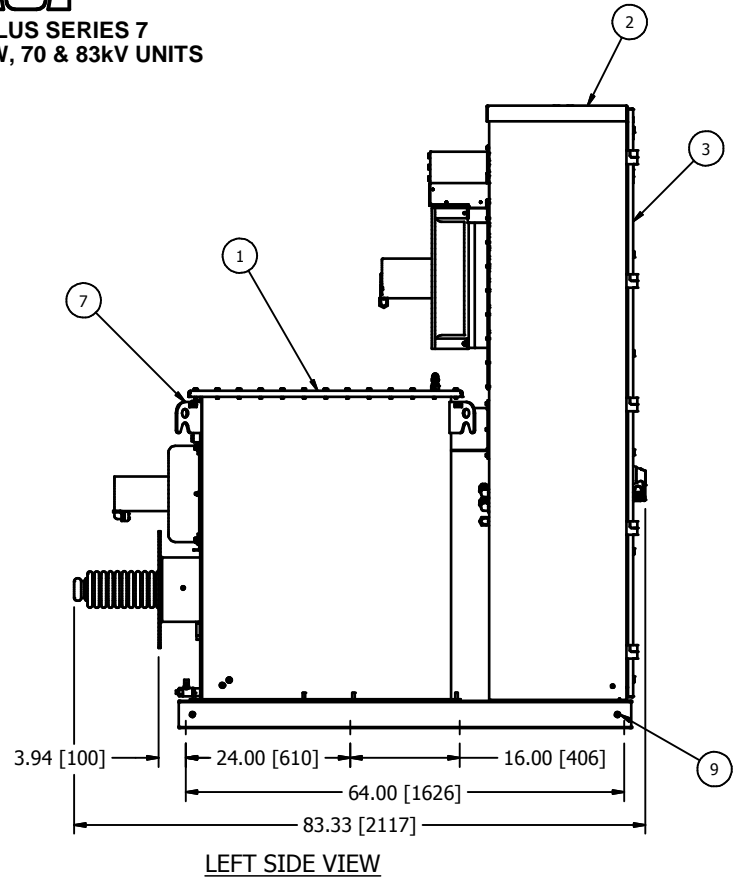
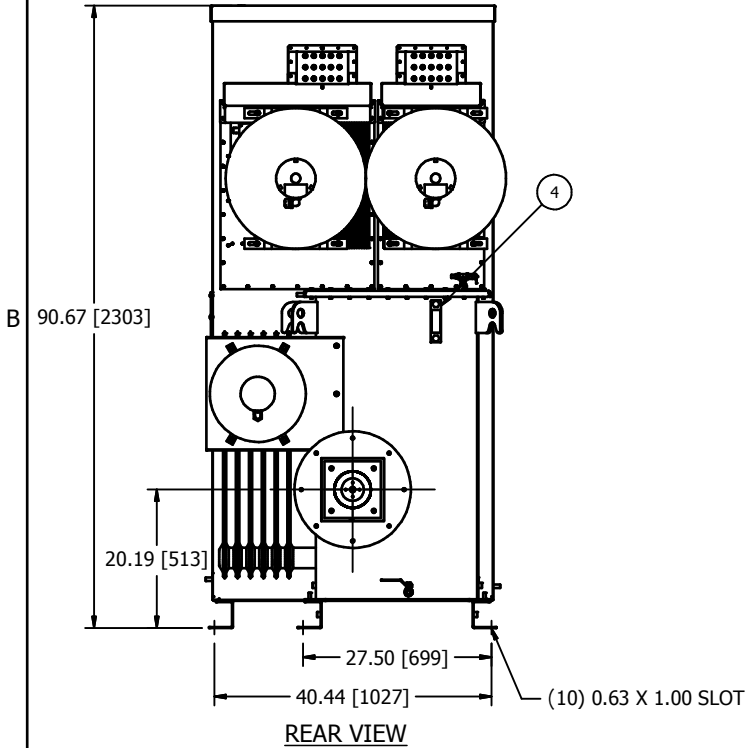

2

1

**NWL****POWERPLUS SERIES 7  
480VAC, 160kW, 70 & 83kV UNITS**

- ① POWERPLUS H.V. TANK
- ② POWERPLUS CONTROLLER UNIT.
- ③ ACCESS DOOR TO CIRCUIT BREAKER TERMINALS, FUSES AND 3 PHASE RECTIFIERS. ALLOW 42" [1067] OF CLEARANCE FROM THIS FACE FOR DOOR SWING.
- ④ LIQUID LEVEL GAUGE AND TEMPERATURE GAUGE FOR OIL TANK
- ⑤ INPUT CIRCUIT BREAKER SWITCH HANDLE WITH INTERLOCK PROVISION INSIDE. FOR ACCEPTABLE INTERLOCKS SEE DWG C140616.
- ⑥ WEATHER TIGHT, RJ45 CONNECTOR FOR NWL HMI CONNECTION.
- ⑦ LIFTING HOOKS (4 PLACES).
- ⑧ RATINGS NAMEPLATE, ALUMINUM PHOTO ETCHED.
- ⑨ EQUIPMENT SAFETY GROUND TERMINATION, 3/8-16 GROUND BOSS.

**ELECTRICAL SPECIFICATIONS**

kW	kVA	Input Voltage 3Ø, 50/60 Hz, ±10%	Output Current mADC	Output Voltage kVDC	Rated Input Current Amps	Circuit Breaker Rating Amps	Losses kW
160	180	480	2285 / 1930	70 / 83	216	300	8.4

Min. Ambient Temp.	Max. Avg. Ambient Temp. (24 hr)	Max. Ambient Temp.
-20°C	40°C	50°C for up to 4 hours over a 24 hour period

EXPORT CRATE DIMENSIONS: 92 (2337mm)L x 48 (1219mm)W x 96 (2438mm)H.  
 EXPORT CRATE WEIGHT: 4000lbs (1815kg).  
 MAXIMUM FLOOR LOADING: 240lbs/sq.ft (1172kgs/sq.m).  
 DIELECTRIC FLUID VOLUME: 134 gal (507L).  
 FINISH: ENAMEL, ASA 61, APPROX. RAL 7042.  
 TANK AND CONTROL ENCLOSURE RATED NEMA 4/IP56.

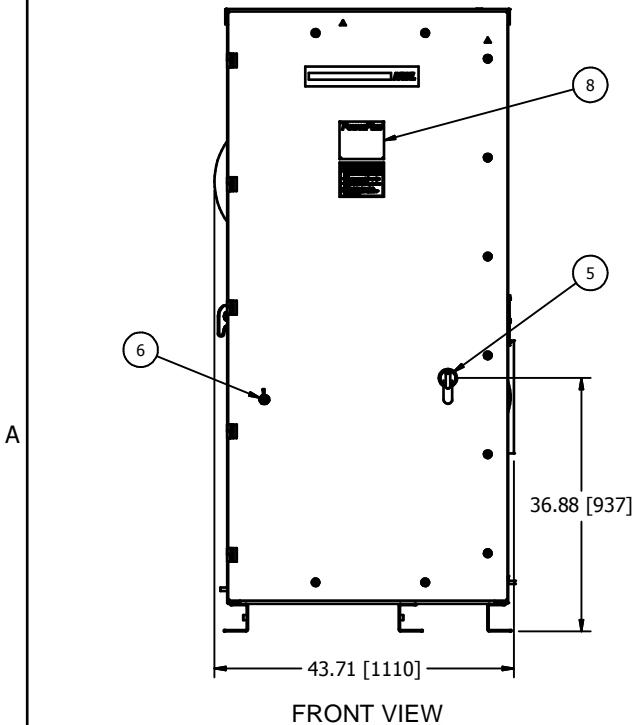

DATA SHEET: 480\_160\_83\_S7

REVISION DATE: 01/29/18

ALL DIMENSIONS IN INCHES [mm]

APPROVED BY: RJK