

2

1

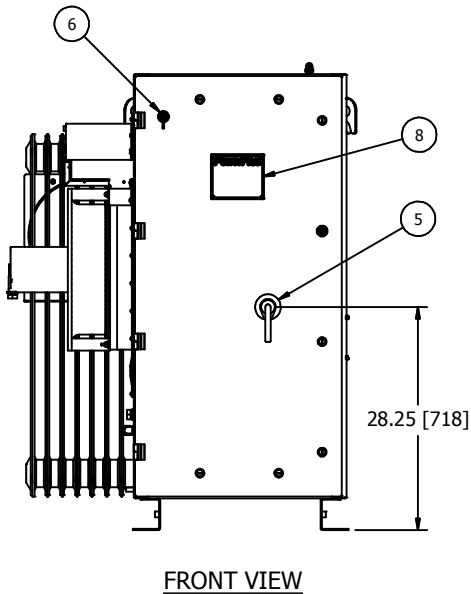

POWERPLUS SERIES 7
480VAC, 105 & 120kW, 70 & 83kV UNITS

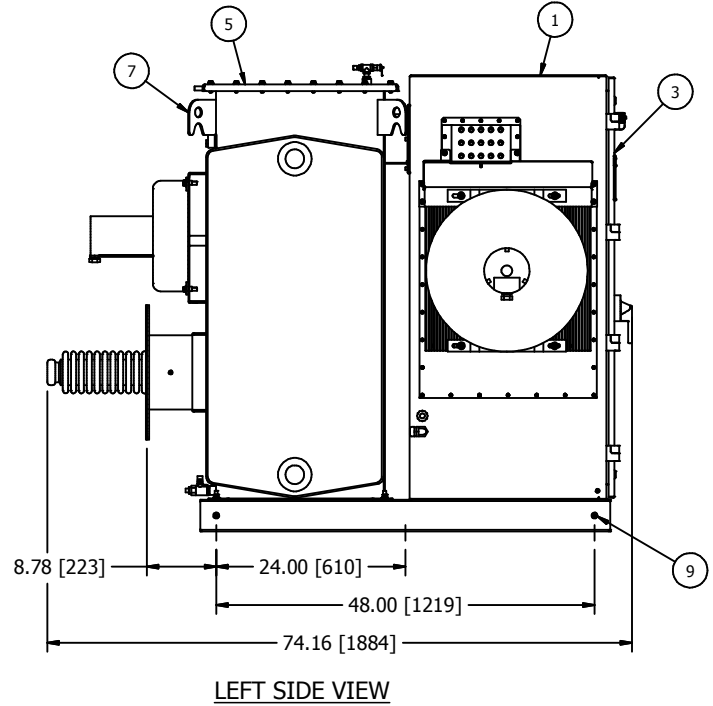
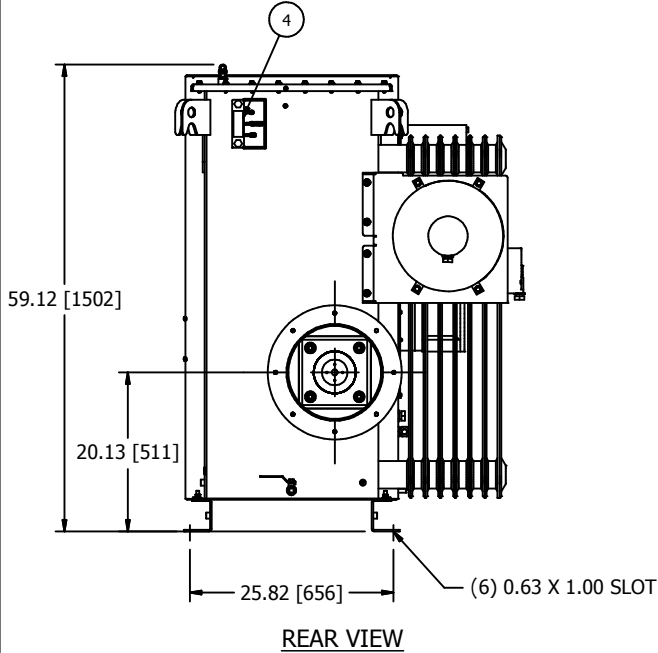

- ① POWERPLUS H.V. TANK AND BASE.
- ② POWERPLUS CONTROLLER UNIT.
- ③ ACCESS DOOR TO CIRCUIT BREAKER TERMINALS, FUSES AND 3 PHASE RECTIFIERS. ALLOW 27" [686] OF CLEARANCE FROM THIS FACE FOR DOOR SWING.
- ④ LIQUID LEVEL GAUGE AND TEMPERATURE GAUGE FOR OIL TANK.
- ⑤ INPUT CIRCUIT BREAKER SWITCH HANDLE WITH INTERLOCK PROVISION INSIDE. FOR ACCEPTABLE INTERLOCKS SEE DWG C140616.
- ⑥ WEATHER TIGHT, RJ45 CONNECTOR FOR NWL HMI CONNECTION.
- ⑦ LIFTING HOOKS (4 PLACES).
- ⑧ RATINGS NAMEPLATE, ALUMINUM PHOTO ETCHED.
- ⑨ EQUIPMENT SAFETY GROUND TERMINATION, 3/8-16 GROUND BOSS.

ELECTRICAL SPECIFICATIONS

kW	kVA	Input Voltage 3Ø, 50/60 Hz, ±10%	Output Current mADC	Output Voltage kVDC	Rated Input Current Amps	Circuit Breaker Rating Amps	Losses kW
105	119	480	1500 / 1265	70 / 83	143	200	5.5
120	134	480	1715 / 1445	70 / 83	161	250	6.3

Min. Ambient Temp.	Max. Avg. Ambient Temp. (24 hr)	Max. Ambient Temp.
-20°C	40°C	50°C for up to 4 hours over a 24 hour period

*NOTE AT 480V ONLY 140kW UNIT AVAILABLE IS LIMITED TO 40°C MAX.

EXPORT CRATE DIMENSIONS: 82 (2082mm)L x 52 (1321mm)W x 68 (1727mm)H.
 EXPORT CRATE WEIGHT: 2220lbs (1007kg).
 MAXIMUM FLOOR LOADING: 200lbs/sq.ft (977kgs/sq.m).
 DIELECTRIC FLUID VOLUME: 100gal (379L).
 FINISH: ENAMEL, ASA 61, APPROX. RAL 7042.
 TANK AND CONTROL ENCLOSURE RATED NEMA 4/IP56.

DATA SHEET: 480_120_83_S7
 REVISION DATE: 01/29/18

ALL DIMENSIONS IN INCHES [mm]

APPROVED BY: RJK