

2

1

POWERPLUS SERIES 7
480VAC, 28 & 35kW, 70 & 83kV UNITS

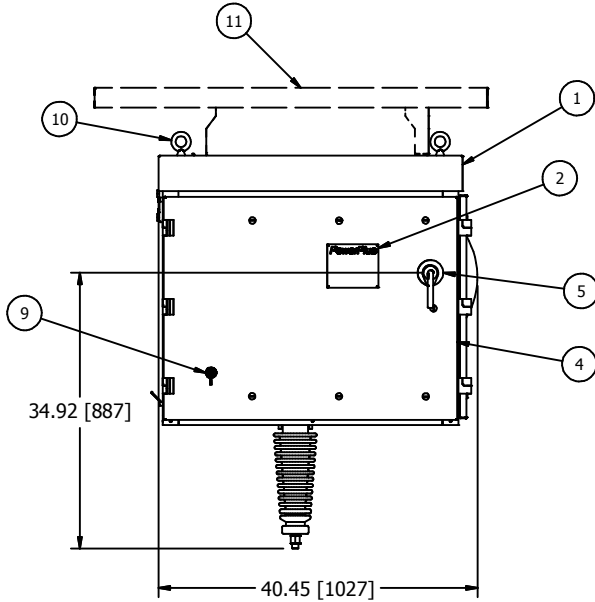

FRONT VIEW

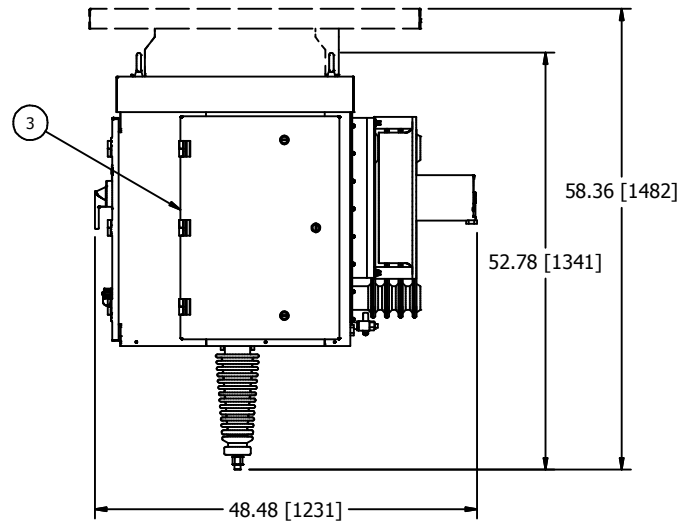

SIDE VIEW

- ① POWERPLUS UNIT
- ② RATINGS NAMEPLATE, ALUMINUM PHOTO ETCHED.
- ③ POWER ELECTRONICS SECTION WITH HINGED DOOR. ALLOW 19" [483] OF CLEARANCE FROM THIS FACE FOR DOOR SWING.
- ④ SWITCHGEAR AND CONTROL SECTION WITH HINGED DOOR. ALLOW 37" [940] OF CLEARANCE FROM THIS FACE FOR DOOR SWING.
- ⑤ INPUT CIRCUIT BREAKER SWITCH HANDLE WITH INTERLOCK PROVISION INSIDE. FOR ACCEPTABLE INTERLOCKS SEE DWG C140616.
- ⑥ 1" [25.4] DIA. CONDUIT HOLE FOR 120V CONTROL WIRING.
- ⑦ 1/2" [12.7] DIA. CONDUIT HOLE FOR LOW VOLTAGE COMMUNICATION AND OPTIONAL TRANSDUCER CONDUIT.
- ⑧ 2" [51] DIA. CONDUIT HOLE FOR 3 PHASE POWER AND GROUND.
- ⑨ WEATHER TIGHT, RJ45 CONNECTOR FOR NWL HMI CONNECTION.
- ⑩ LIFTING EYES (4 PLACES).
- ⑪ OPTIONAL SUN SHIELD MUST BE SHIPPED SEPARATELY AND INSTALL IN THE FIELD.

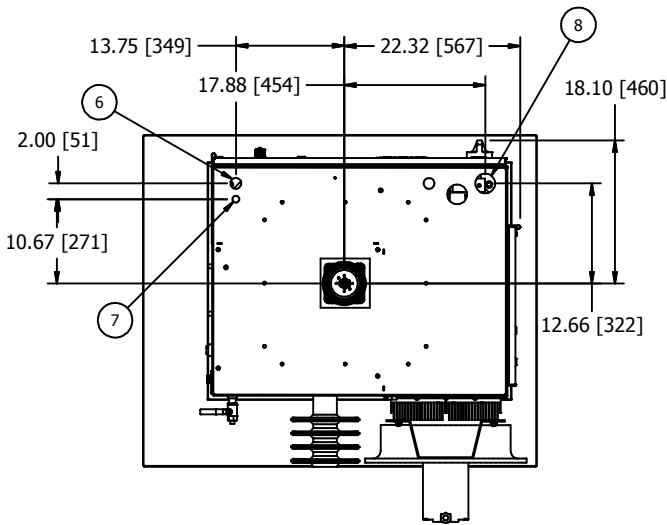

BOTTOM VIEW

ELECTRICAL SPECIFICATIONS

| kW | kVA | Input Voltage 3Ø, 50/60 Hz, ±10% | Output Current mADC | Output Voltage KVDC | Rated Input Current Amps | Circuit Breaker Rating Amps | Losses kW |
|----|------|----------------------------------------|------------------------|------------------------|-----------------------------|--------------------------------|--------------|
| 28 | 32.2 | 480 | 400 / 335 | 70 / 83 | 39 | 60 | 2.0 |
| 35 | 39.1 | 480 | 500 / 420 | 70 / 83 | 48 | 70 | 2.1 |

| Min. Ambient Temp. | Max. Avg. Ambient Temp. (24 hr) | Max. Ambient Temp. |
|--------------------|---------------------------------|----------------------------------------------|
| -20°C | 40°C | 50°C for up to 4 hours over a 24 hour period |

EXPORT CRATE DIMENSIONS: 58 (1473mm)L x 50 (1270mm)W x 94 (2388mm)H.*
 EXPORT CRATE WEIGHT: 1611lbs (731kg).*
 MAXIMUM FLOOR LOADING: 280lbs/sq.ft (1368kgs/sq.m).*
 DIELECTRIC FLUID VOLUME: 26gal (99L).
 FINISH: ENAMEL, ASA 61, APPROX. RAL 7042.
 TANK AND CONTROL ENCLOSURE RATED NEMA 4/IP56.

*DIMENSIONS AND WEIGHT ARE BASED ON POWERPLUS MOUNTED ON A SQUARE SIDE EXIT GROUND SWITCH.

DATA SHEET: 480_35_83_S7

REVISION DATE: 01/29/18

APPROVED BY: RJK

ALL DIMENSIONS IN INCHES [mm]

C:\vaulwork\Inventor Designs\480_35_83_S7.idw