

2

1



POWERPLUS SERIES 7
480VAC, 56 & 70kW, 70 & 83kV UNITS

B

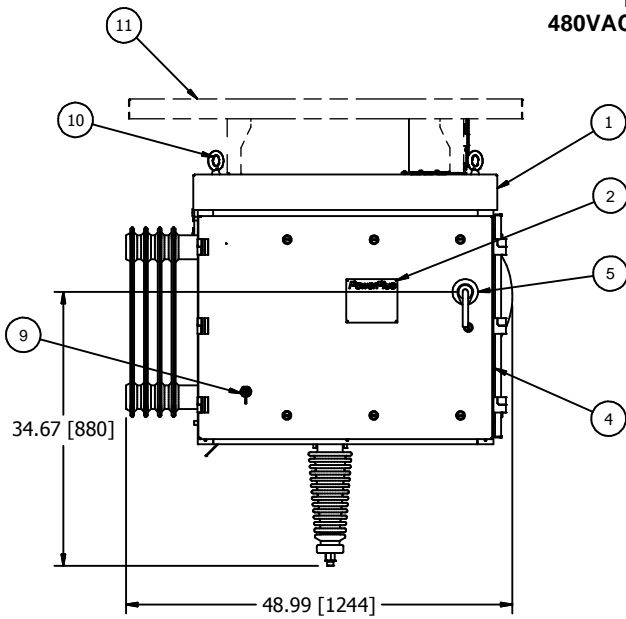

FRONT VIEW

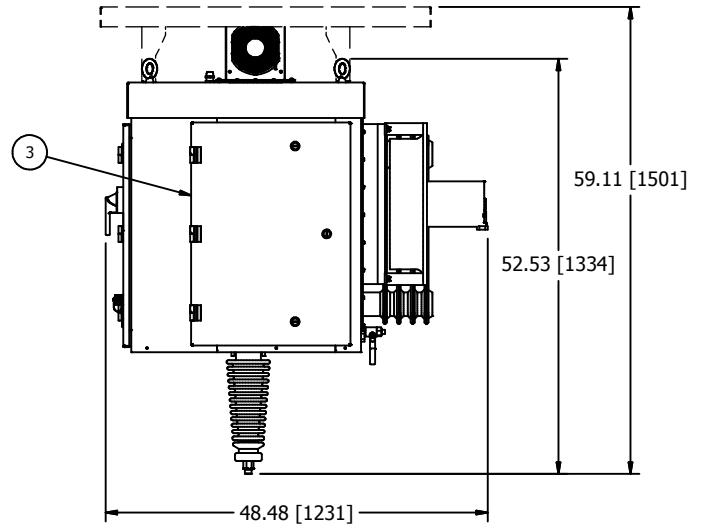

SIDE VIEW

- ① POWERPLUS UNIT
- ② RATINGS NAMEPLATE, ALUMINUM PHOTO ETCHED.
- ③ POWER ELECTRONICS SECTION WITH HINGED DOOR. ALLOW 19" [483] OF CLEARANCE FROM THIS FACE FOR DOOR SWING.
- ④ SWITCHGEAR AND CONTROL SECTION WITH HINGED DOOR. ALLOW 37" [940] OF CLEARANCE FROM THIS FACE FOR DOOR SWING.
- ⑤ INPUT CIRCUIT BREAKER SWITCH HANDLE WITH INTERLOCK PROVISION INSIDE. FOR ACCEPTABLE INTERLOCKS SEE DWG C140616.
- ⑥ 1" [25.4] DIA. CONDUIT HOLE FOR 120V CONTROL WIRING.
- ⑦ 1/2" [12.7] DIA. CONDUIT HOLE FOR LOW VOLTAGE COMMUNICATION AND OPTIONAL TRANSDUCER CONDUIT.
- ⑧ 2" [51] DIA. CONDUIT HOLE FOR 3 PHASE POWER AND GROUND.
- ⑨ WEATHER TIGHT, RJ45 CONNECTOR FOR NWL HMI CONNECTION.
- ⑩ LIFTING EYES (4 PLACES).
- ⑪ OPTIONAL SUN SHIELD MUST BE SHIPPED SEPARATELY AND INSTALL IN THE FIELD.

A

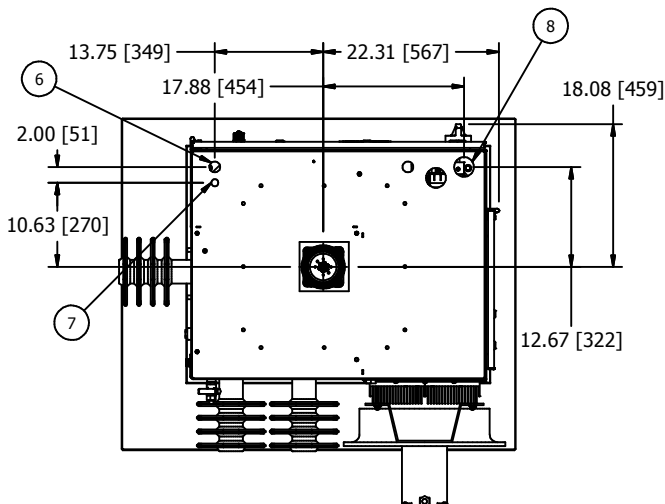

BOTTOM VIEW

ELECTRICAL SPECIFICATIONS

kW	kVA	Input Voltage 3Ø, 50/60 Hz, ±10%	Output Current mADC	Output Voltage kVDC	Rated Input Current Amps	Circuit Breaker Rating Amps	Losses kW
56	63	480	800 / 675	70 / 83	76	100	3.6
70	78	480	1000 / 840	70 / 83	94	150	4.4

Min. Ambient Temp.	Max. Avg. Ambient Temp. (24 hr)	Max. Ambient Temp.
-20°C	40°C	50°C for up to 4 hours over a 24 hour period

EXPORT CRATE DIMENSIONS: 58 (1473mm)L x 58 (1473mm)W x 94 (2388mm)H.*
 EXPORT CRATE WEIGHT: 1700lbs (771kg).*
 MAXIMUM FLOOR LOADING: 305lbs/sq.ft (1489kgs/sq.m).*
 DIELECTRIC FLUID VOLUME: 29gal (110L).
 FINISH: ENAMEL, ASA 61, APPROX. RAL 7042.
 TANK AND CONTROL ENCLOSURE RATED NEMA 4/IP56.

*DIMENSIONS AND WEIGHT ARE BASED ON POWERPLUS MOUNTED
 ON A SQUARE SIDE EXIT GROUND SWITCH.

DATA SHEET: 480_70_83_S7

REVISION DATE: 8/1/16

APPROVED BY: RJK

ALL DIMENSIONS IN INCHES [mm]