

DETAIL A
SCALE 1 / 7

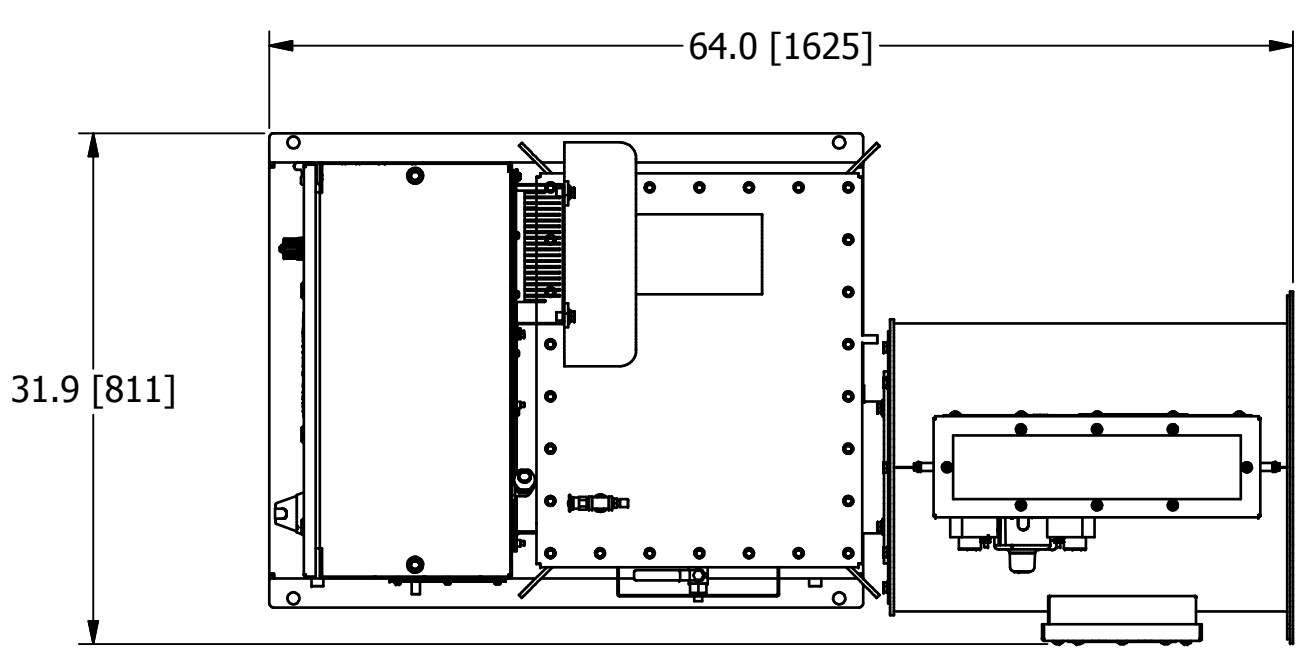

TOP VIEW

3 PHASE CIRCUIT BREAKER PER DWG ESPELECT-06
TABS TO ACCEPT 3/8" LUGS, TORQUE TO 80in-lbs.

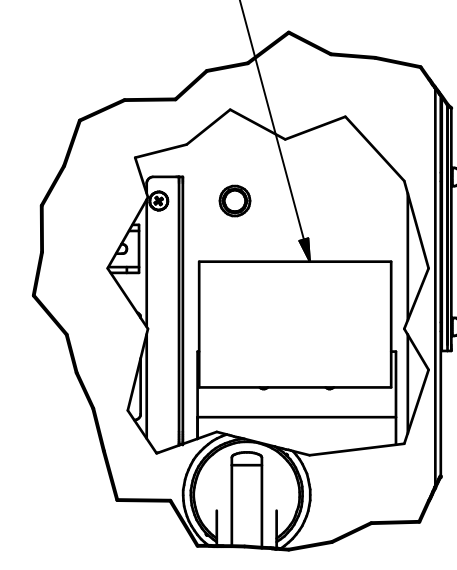

DETAIL C
CIRCUIT BREAKER DETAIL
SCALE 1 / 4

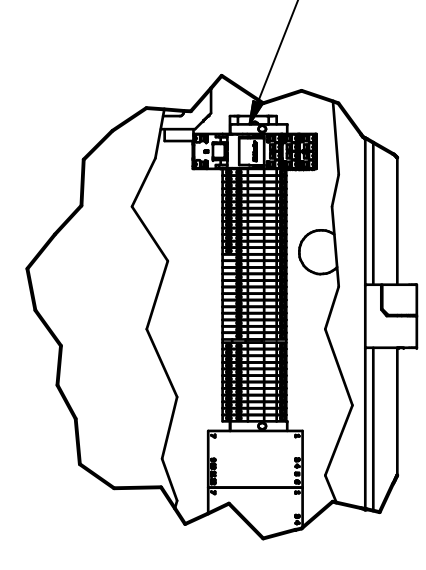

DETAIL D
'2TB' TERMINAL BLOCK RAIL ASSY
SCALE 1 / 6

FOR DETAILS REFER TO
DWG ESPELECT-06

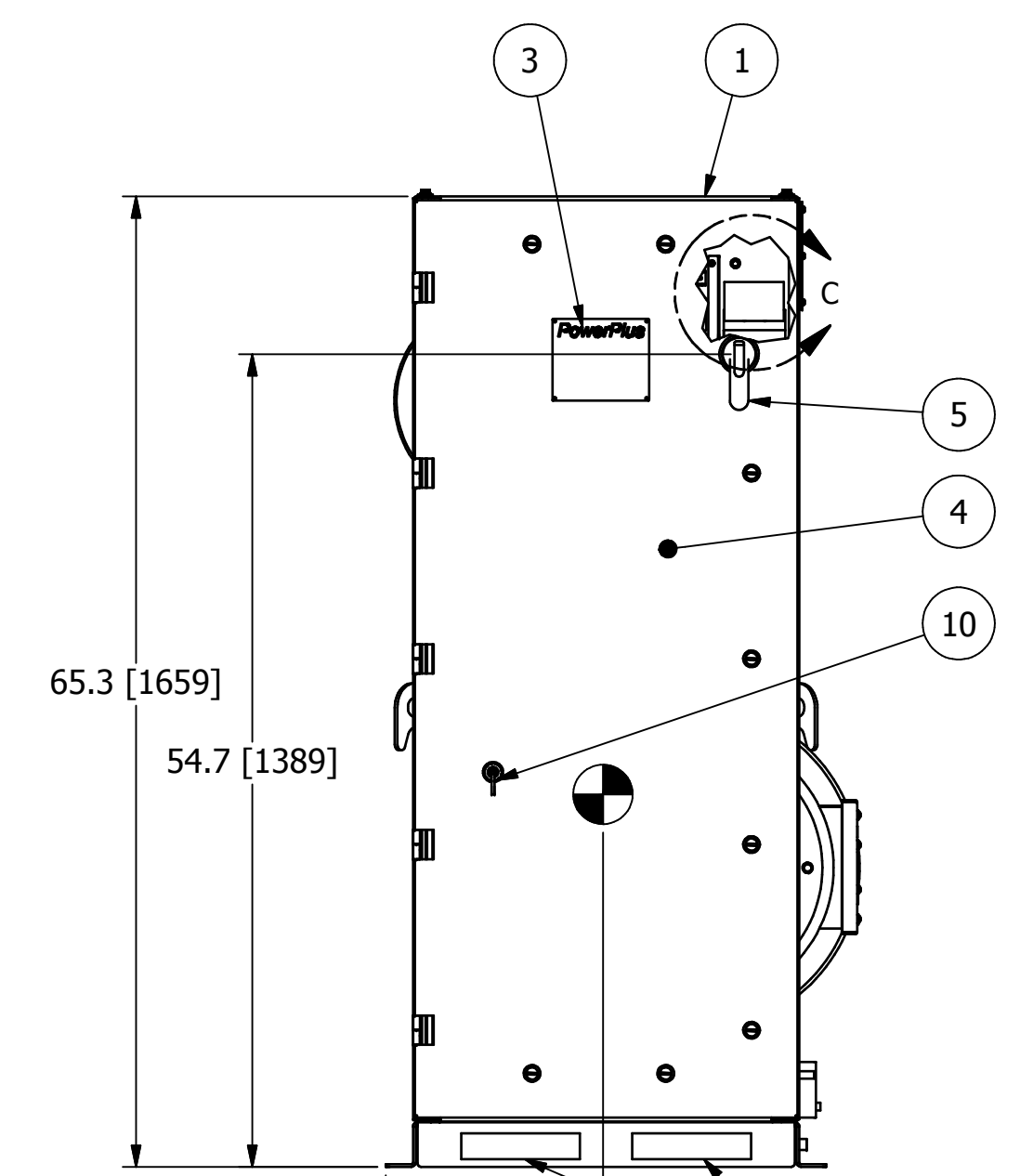
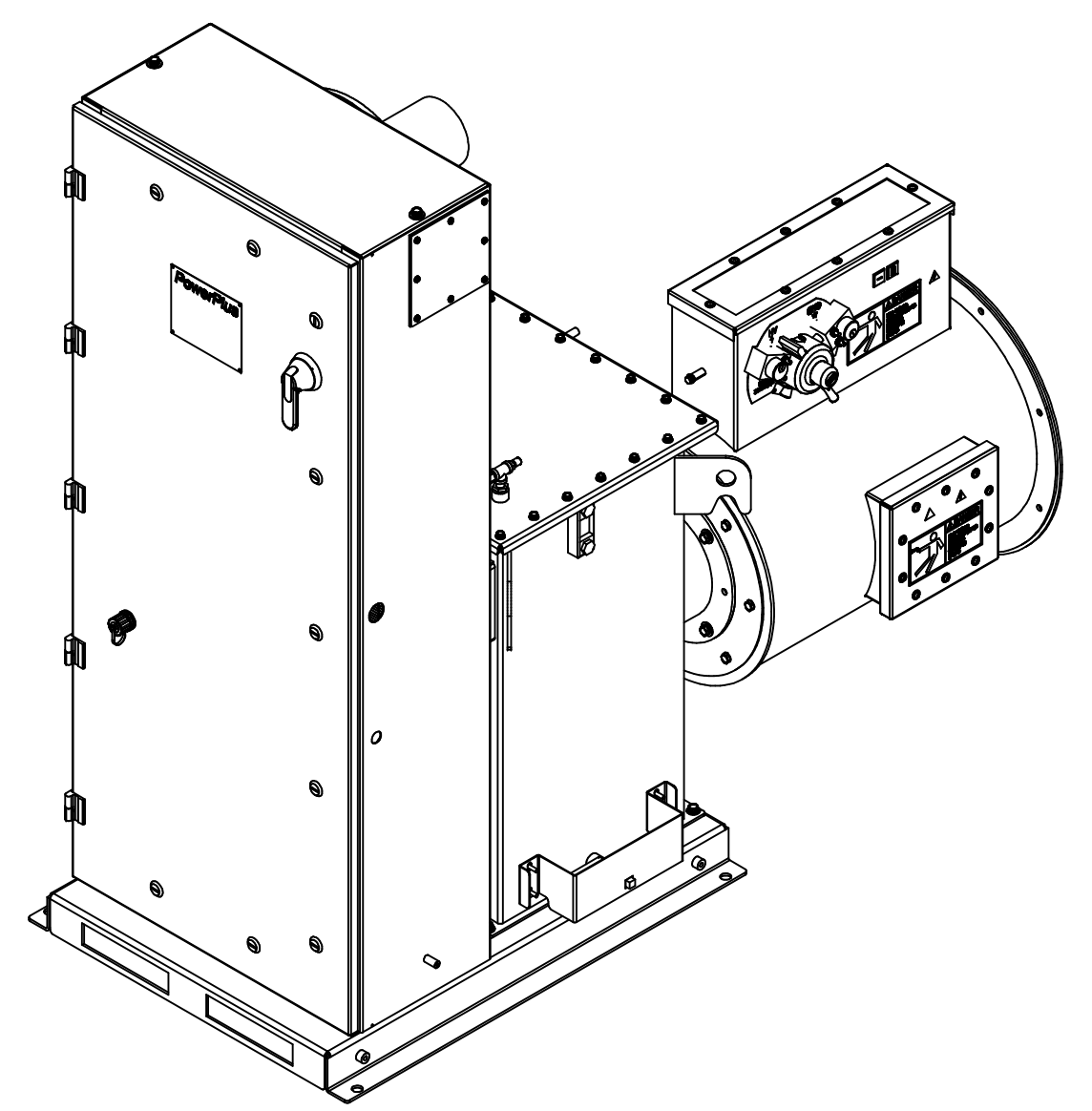

FRONT VIEW

FORK LIFT
PROVISIONS

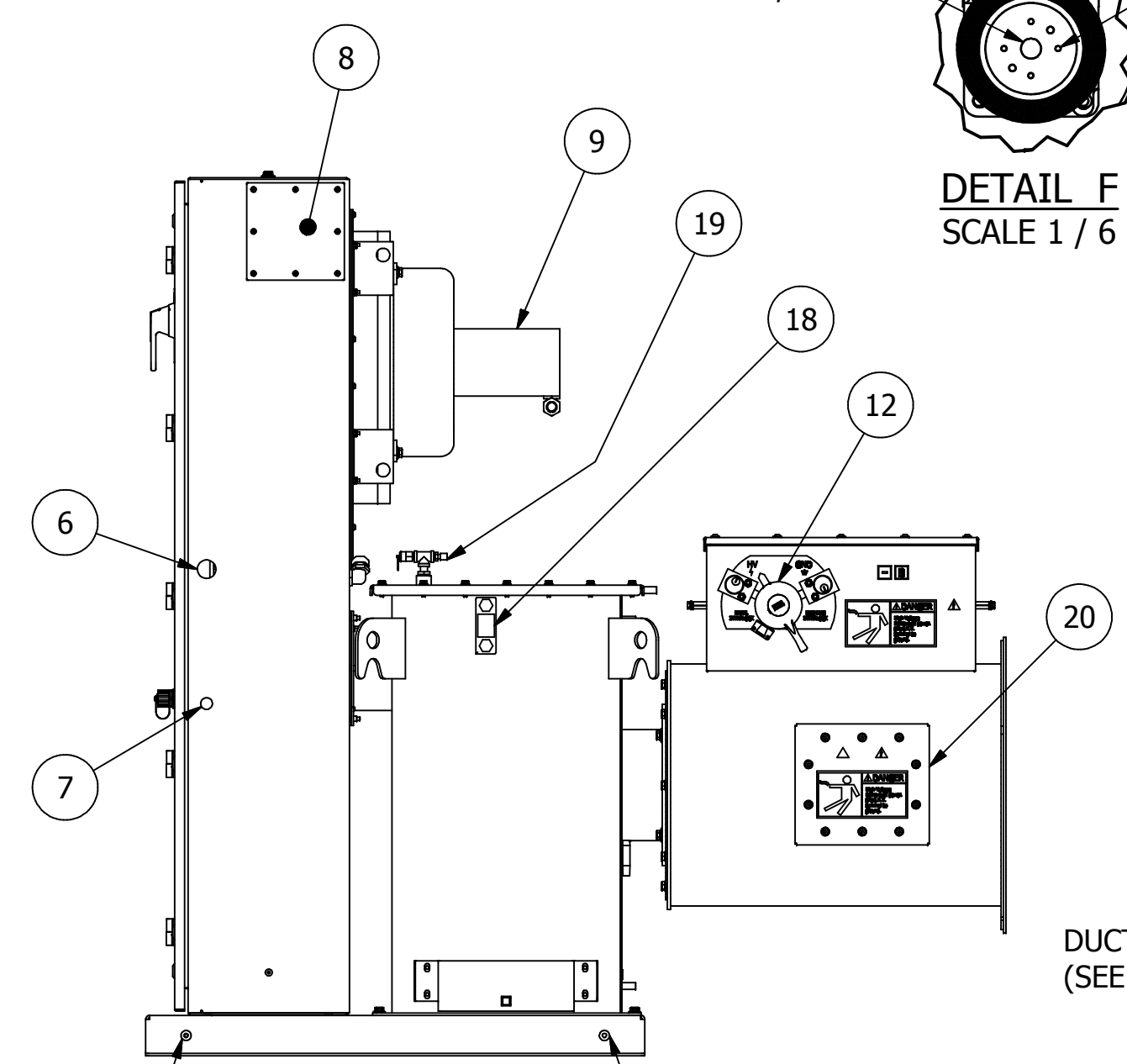

RIGHT VIEW

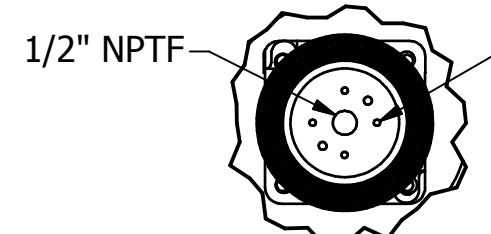

DETAIL F
SCALE 1 / 6

(4) 1/4-20 UNC - 1B
EQUALLY SPACED ON
A Ø2.00 BC

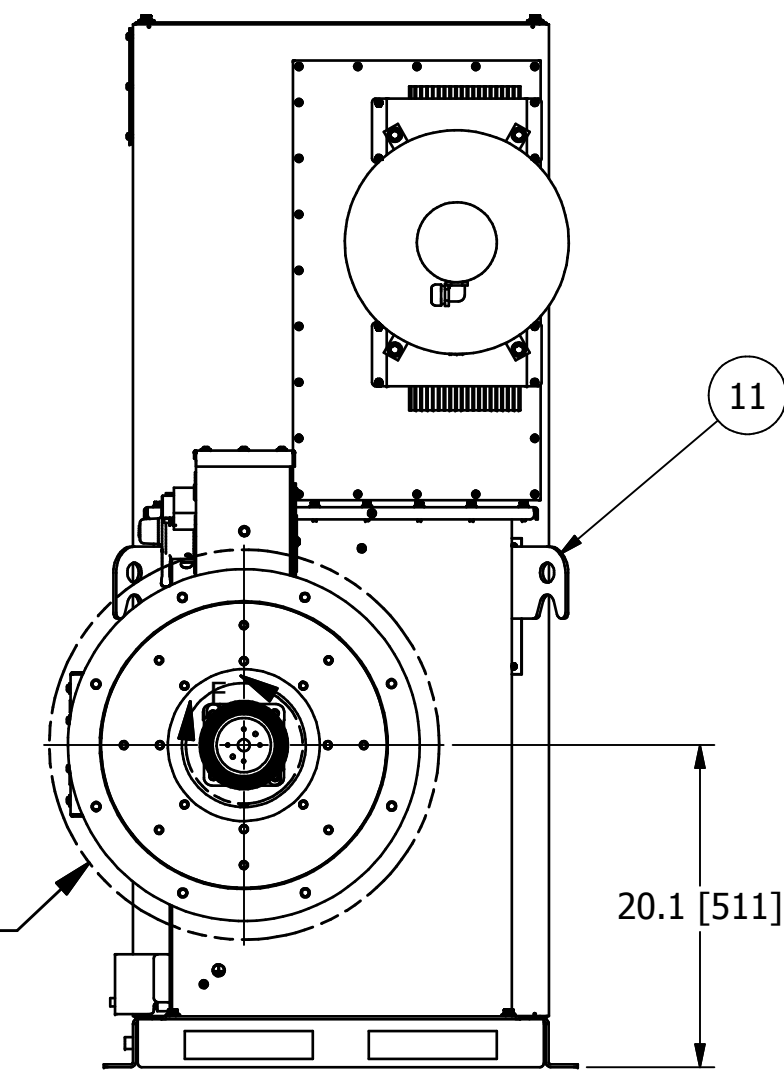

REAR VIEW

DUCT OPENING
(SEE DETAIL 'A')

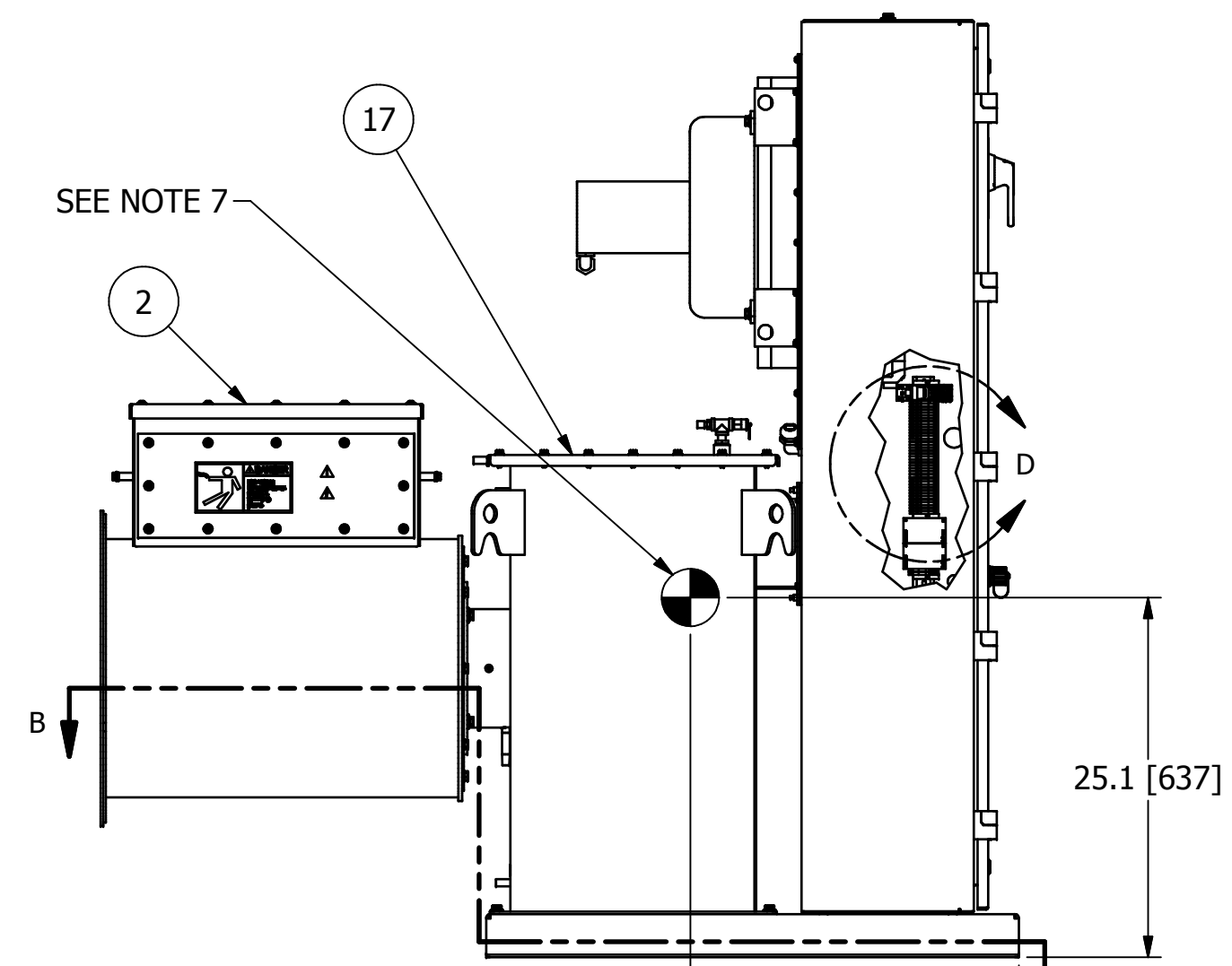

LEFT VIEW

SEE NOTE 7

- BALLOONED NUMBERS:**
- ① POWERPLUS UNIT.
 - ② GROUND SWITCH
 - ③ RATINGS NAMEPLATE, ALUMINUM PHOTO ETCHED.
 - ④ ACCESS DOOR TO SWITCHGEAR AND CONTROL SECTION. ALLOW 27" [686] OF CLEARANCE FROM THIS FACE FOR DOOR SWING.
 - ⑤ INPUT CIRCUIT BREAKER SWITCH HANDLE W/ INTERLOCK PROVISION INSIDE. SEE DWG C140616.
 - ⑥ 1" [25.4] DIA. CONDUIT HOLE FOR 120V CONTROL WIRING.
 - ⑦ 1/2" [12.7] DIA. CONDUIT HOLE FOR LOW VOLTAGE TRANSDUCER AND COMMUNICATION LINK CONDUIT.
 - ⑧ GLAND PLATE FOR 3 PHASE POWER AND GROUND.
 - ⑨ COOLING FAN FOR IGBT HEATSINK ASSEMBLY.
 - ⑩ WEATHER TIGHT, RJ45 CONNECTOR FOR NWL HMI CONNECTION
 - ⑪ LIFTING HOOKS (4 PLACES).
 - ⑫ H.V. SWITCH MECHANISM W/ VIEWING WINDOW AND INTERLOCK PROVISIONS. SEE DWG A105812.
 - ⑬ SIDE EXIT 18" DUCT MOUNTING PROVISION. INCLUDES GASKETS AND 3/8-16 HARDWARE, (8) PLACES ON A 20" [508] DIA. WITH 18" [457] DIA. DUCT OPENING.
 - ⑭ 1/2" NPT OUTPUT CONNECTION.
 - ⑮ OPTIONAL METRIC ADAPTER FOR H.V. BUSHING CONNECTION. CONVERTS 1/2" NPT TO M20-1.5. SEE DWGA117570.
 - ⑯ EQUIPMENT SAFETY GROUND TERMINATION, 3/8-16 GROUND BOSS.
 - ⑰ HIGH VOLTAGE OIL TANK W/OIL LEVEL SIGHT GLASS AND PRESSURE RELIEF VALVE.
 - ⑱ OIL LEVEL SIGHT GLASS
 - ⑲ PRESSURE RELIEF VALVE
 - ⑳ REMOVABLE ACCESS PANEL FOR BUSHING CONNECTION AND MAINTENANCE.

- SHIPPING NOTES:**
1. POWERPLUS WILL BE SHIPPED WITH ROUND GROUND SWITCH.
 2. ROUND GROUND SWITCH WILL BE SHIPPED WITH GASKET AND MOUNTING HARDWARE.
 3. POWERPLUS SHIPPING WEIGHT: 950lbs [431kg]
 4. ROUND GROUND SWITCH SHIPPING WEIGHT: 100lbs [46kg]
 5. DIELECTRIC FLUID VOLUME: 41gal [154L]
 6. FINISH: ENAMEL, ASA 61, APPROX. RAL 7042.
 7. INDICATES CENTER OF GRAVITY

- INSTALLATION NOTES:**
1. POWERPLUS MUST BE MOUNTED ON LEVEL SURFACE OR SHIMMED TO WITHIN 1/8" [3.2] RISE PER 12" [305] RUN.
 2. COLD ROOF MAY NEED TO BE REINFORCED TO ACCEPT THE WEIGHT OF THE POWERPLUS UNIT.
 3. MAXIMUM ALLOWABLE DUCT INTERNAL TEMPERATURE: 122°F (50°C). MAXIMUM ALLOWABLE DUCT INTERNAL PRESSURE: 1 PSI (2.04" Hg). THE INSTALLER MUST USE AN ENTRANCE BUSHING IN ROOF TO MEET THESE SPECIFICATIONS.
 4. POWERPLUS MUST BE GROUNDED TO THE COLD ROOF BY THE END USER. REFER TO DWG B126972 FOR GROUNDING DETAILS.
 5. ALLOW 120" MINIMUM CLEARANCE ABOVE THE FLOOR TO LIFT AND REMOVE THE T/R RIG ASSEMBLY FROM THE OIL TANK. CLEARANCE DOES NOT INCLUDE RIGGING HEIGHT.
 6. POWERPLUS AND SWITCH ARE SEALED, RATED NEMA 4/IP56.

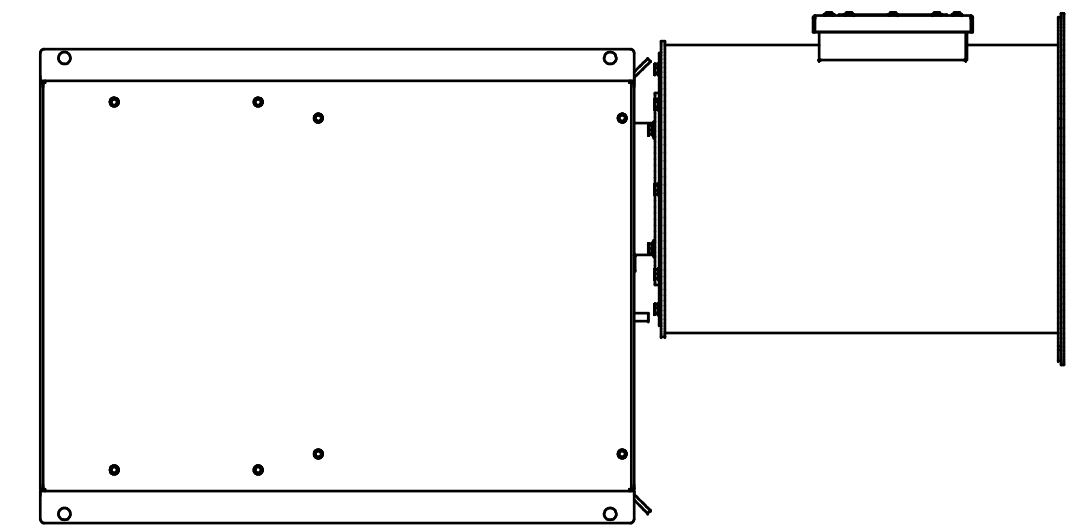

BOTTOM VIEW

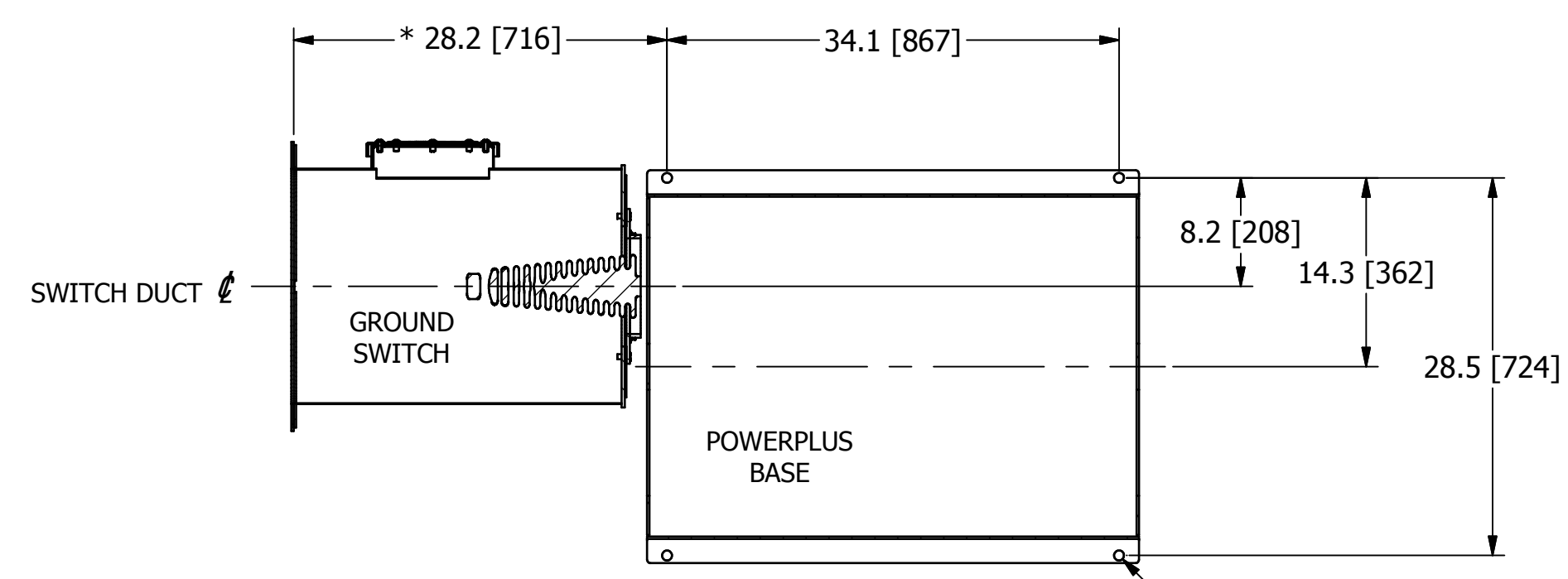

MOUNTING ARRANGEMENT FROM TOP VIEW
(SECTION B-B)

* FOR REFERENCE ONLY. POWERPLUS ASSEMBLY
MUST BE FIELD FITTED TO THE H.V. DUCT WORK
PRIOR TO SECURING TO ROOF.

ALL DIMENSIONS IN INCHES [mm]

NWL 312 RISING SUN RD BORDENTOWN, NJ 08505 TEL. (609) 298-7300 FAX. (609) 298-1982		
TITLE:	HF ESP, POWERPLUS SERIES 7, 17-21kW UNITS, w/ GROUND SWITCH	
SCALE:	APP'D BY:	REVISION DATE:
N/A	RJK	01/29/18
DWG BY:	D.E.:	DWG:
KAF	RJK	17-21RD_S7
TOLERANCES: (UNLESS OTHERWISE SPECIFIED) ANGLES +/- 5 DEG DECIMALS +/- 0.05 FRACTIONS +/- 3/16		NWL PROPRIETARY INFORMATION, NOT TO BE REPRODUCED WITHOUT WRITTEN CONSENT