

8 7 6 5 4 3 2 1

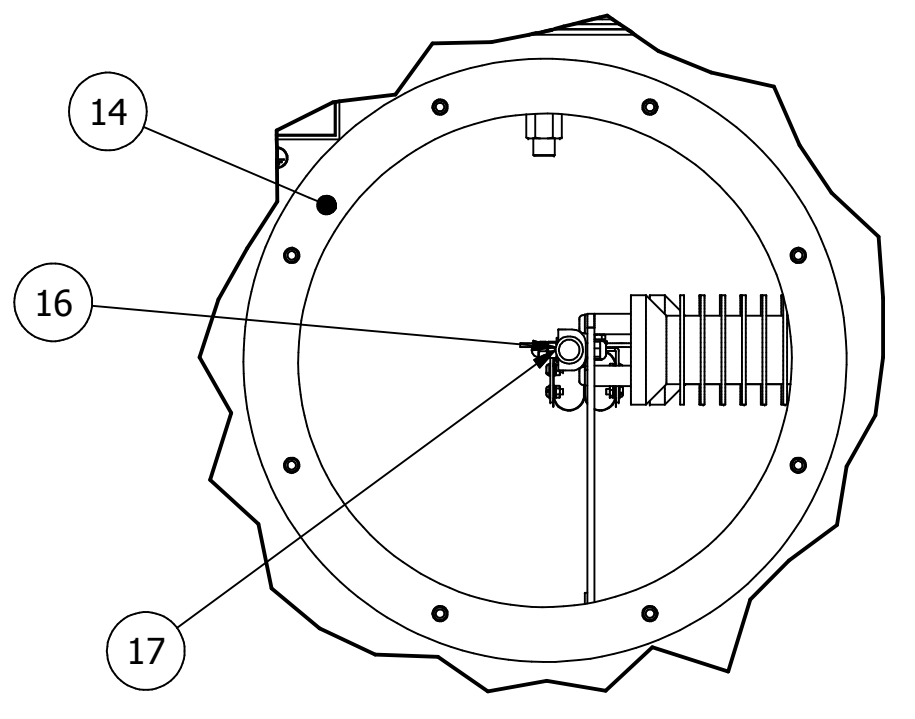

**DETAIL A**  
SCALE 1 / 7

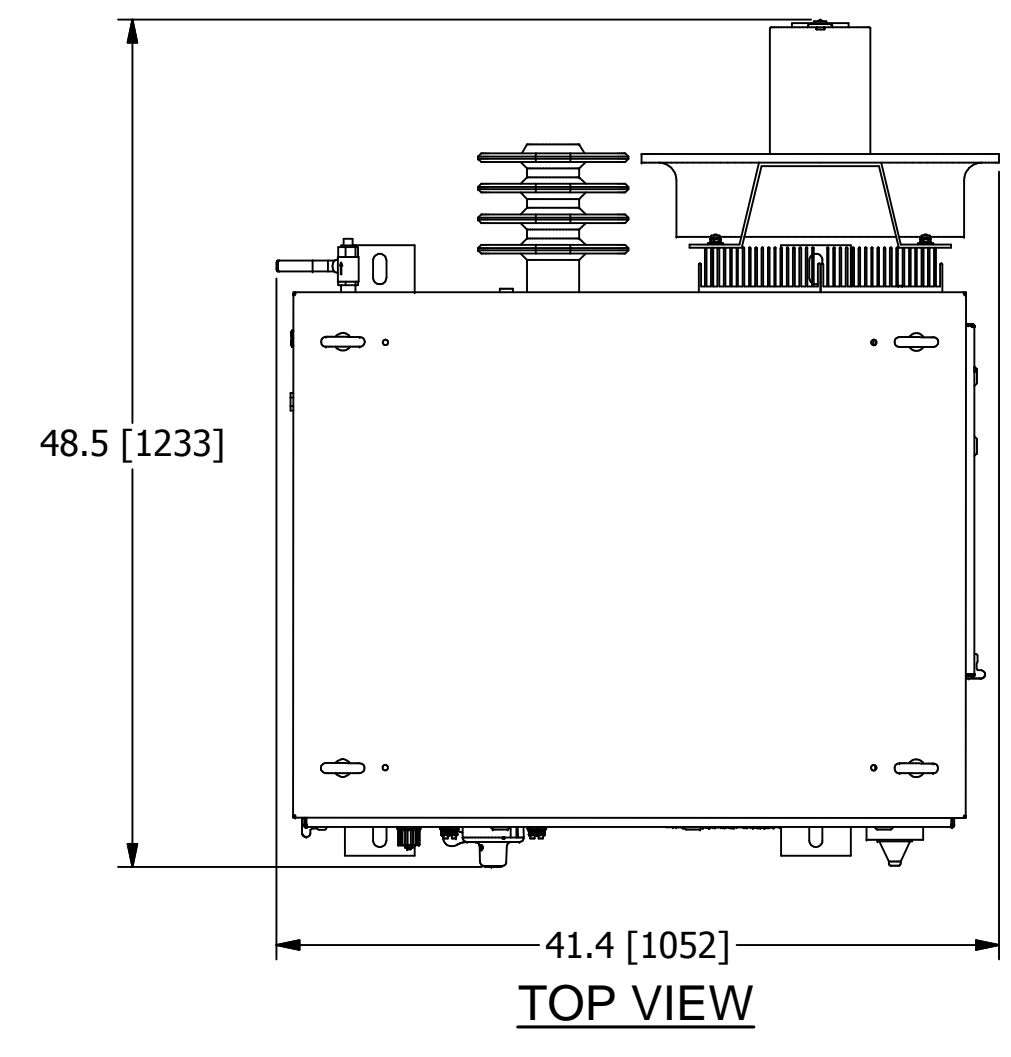

**TOP VIEW**

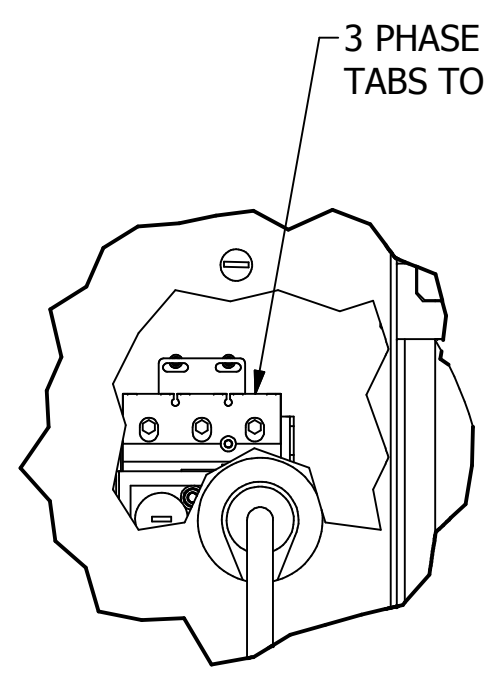

**DETAIL C**  
CIRCUIT BREAKER DETAIL  
SCALE 1 / 5

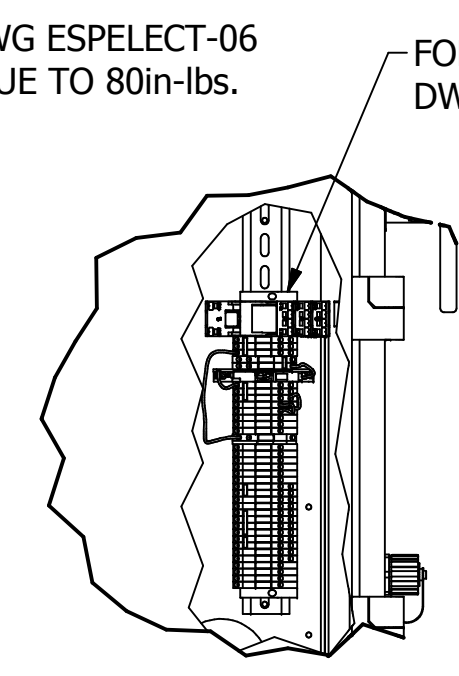

**DETAIL D**  
'2TB' TERMINAL BLOCK RAIL ASSY  
SCALE 1/6

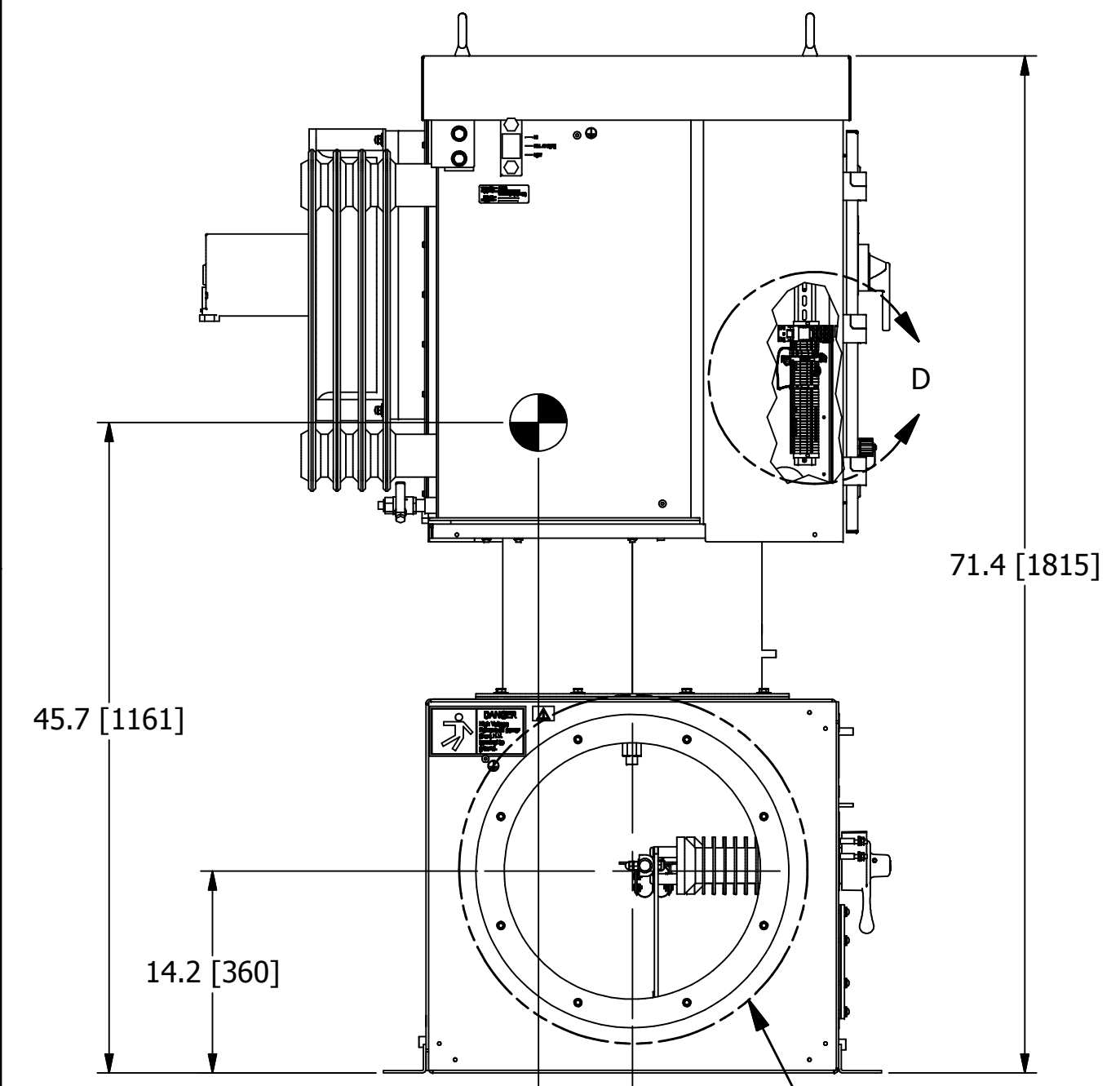
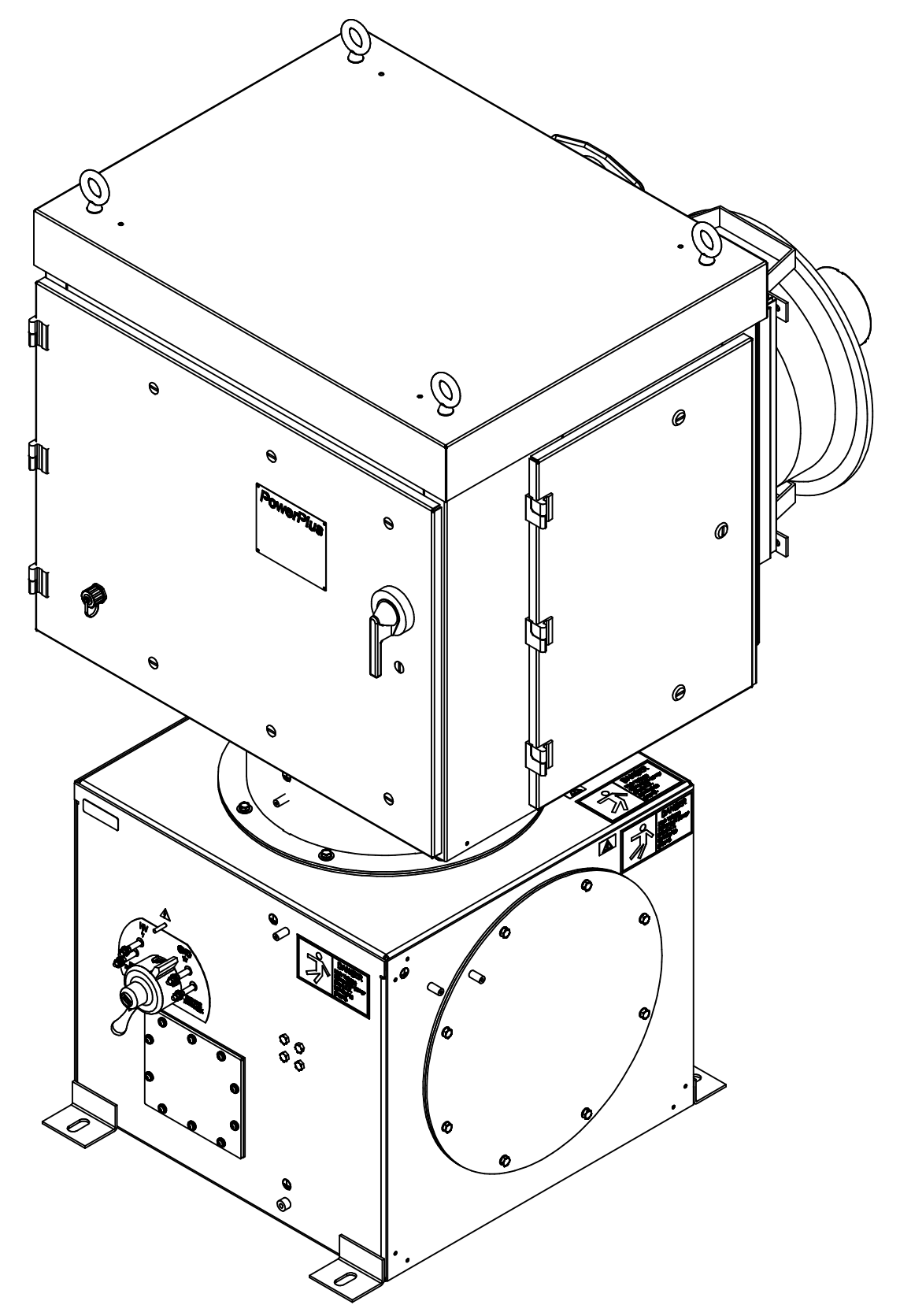

**LEFT VIEW**

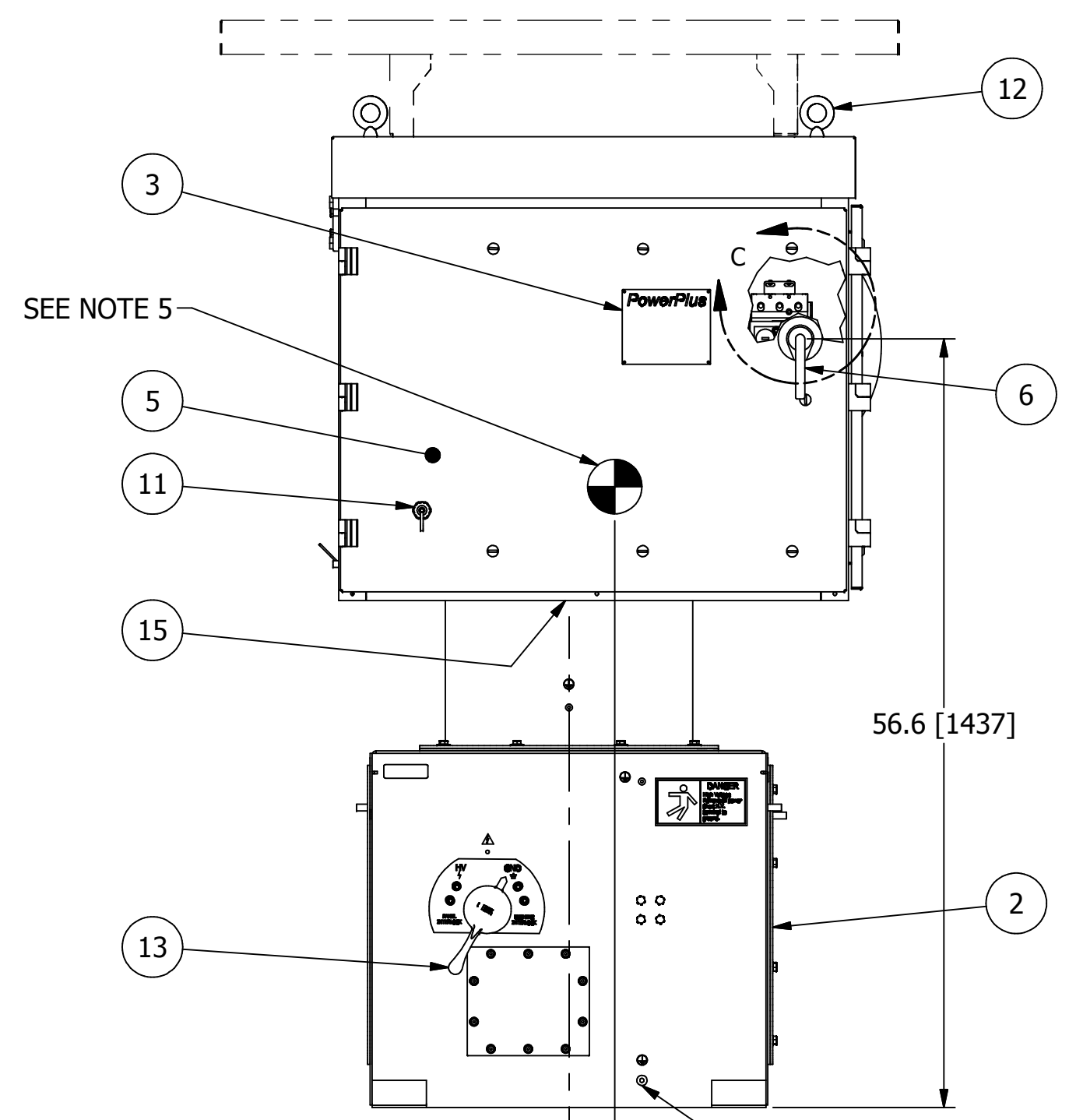

**FRONT VIEW**

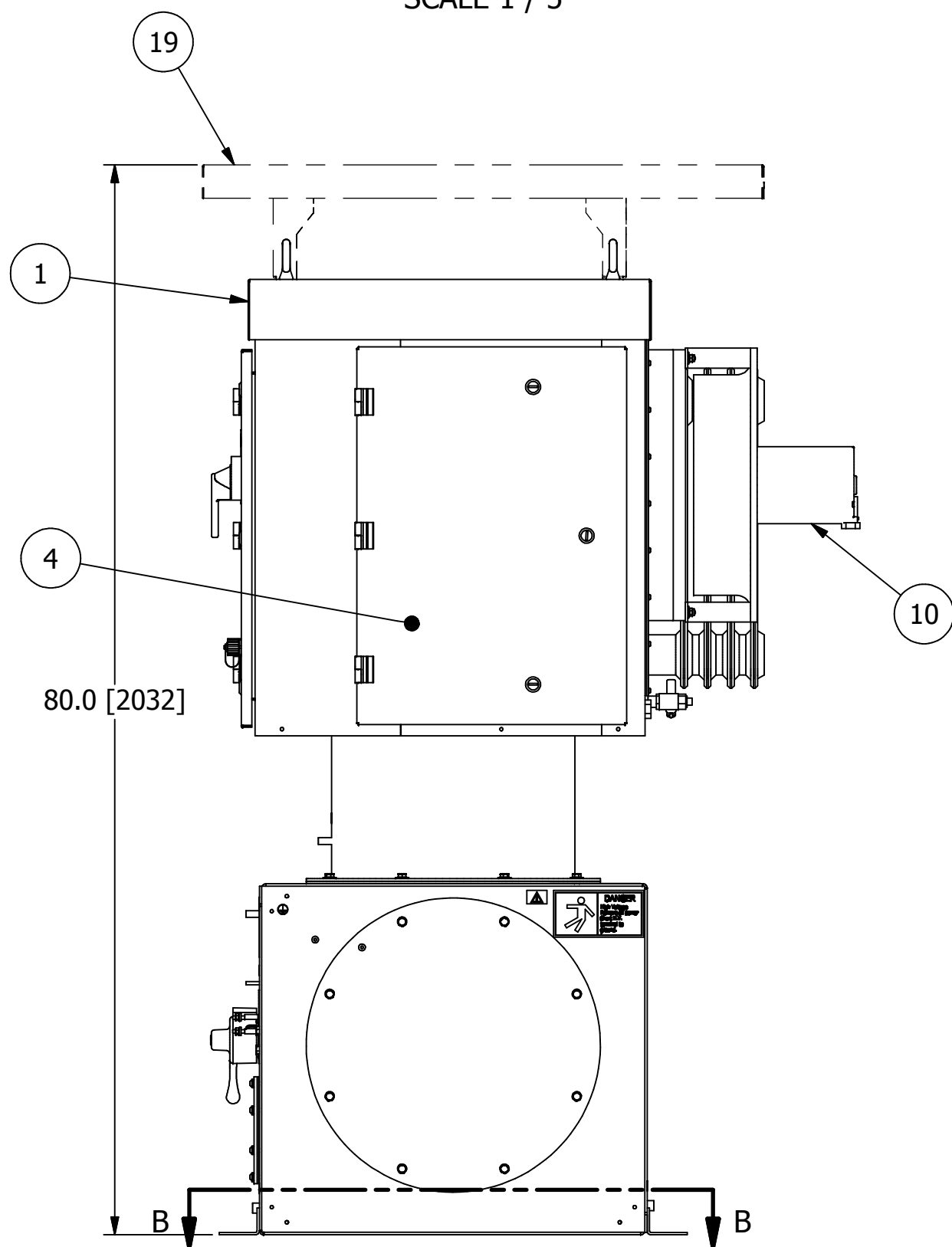

**RIGHT VIEW**

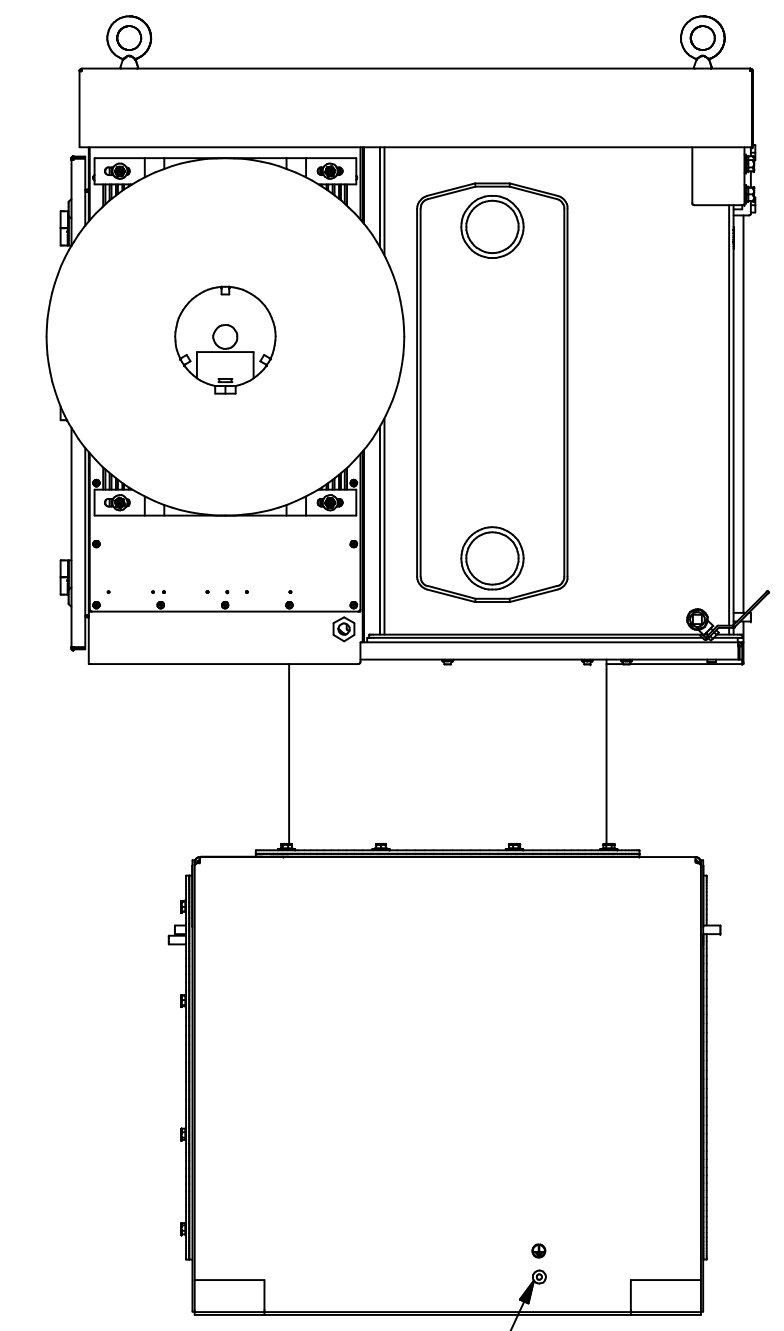

**REAR VIEW**

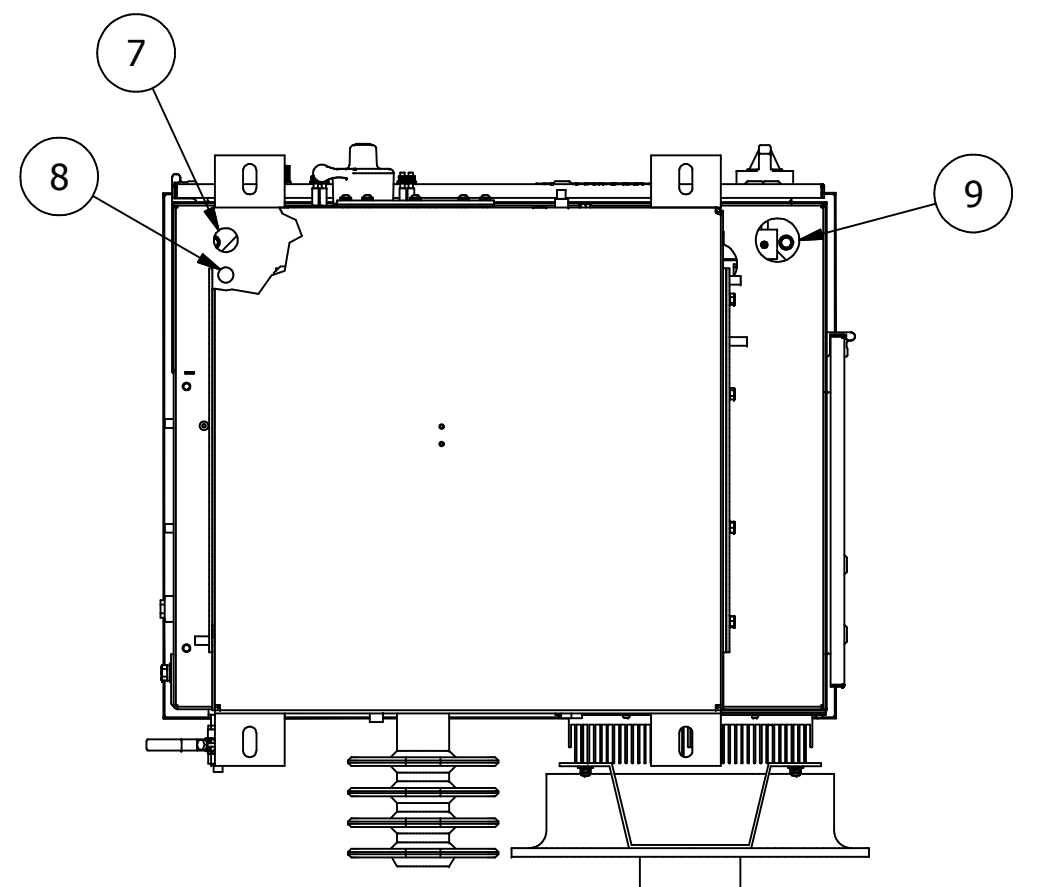

**BOTTOM VIEW**

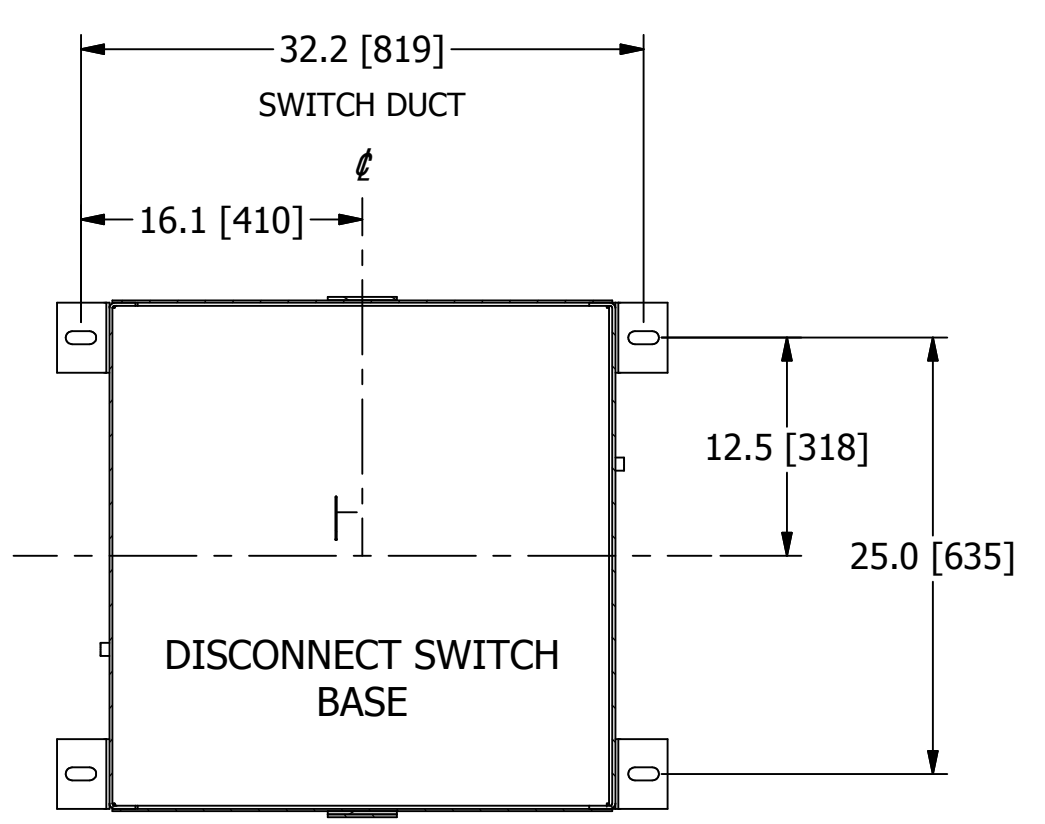

**MOUNTING ARRANGEMENT FROM TOP VIEW**  
SECTION B-B

**SHIPPING NOTES:**  
 1. POWERPLUS WILL BE SHIPPED WITH DISCONNECT GROUND SWITCH.  
 2. POWERPLUS AND DISCONNECT GROUND SWITCH COMBINED SHIPPING WEIGHT: 1200lbs [544kg]  
 3. DIELECTRIC FLUID VOLUME: 29gal [110L]  
 4. FINISH: ENAMEL, ASA 61, APPROX. RAL 7042.  
 5. INDICATES CENTER OF GRAVITY.

**INSTALLATION NOTES:**  
 1. POWERPLUS MUST BE MOUNTED ON LEVEL SURFACE OR SHIMMED TO WITHIN 1/8" [3.2] RISE PER 12" [305] RUN.  
 2. COLD ROOF MAY NEED TO BE REINFORCED TO ACCEPT THE WEIGHT OF THE POWERPLUS UNIT.  
 3. MAXIMUM ALLOWABLE DUCT INTERNAL TEMPERATURE: 122°F (50°C). MAXIMUM ALLOWABLE DUCT INTERNAL PRESSURE: 1 PSI (2.04" Hg). THE INSTALLER MUST USE AN ENTRANCE BUSHING IN ROOF TO MEET THESE SPECIFICATIONS.  
 4. POWERPLUS MUST BE GROUNDED TO THE COLD ROOF BY THE END USER. REFER TO DWG B126972 FOR GROUNDING DETAILS.  
 5. ALLOW 120" MINIMUM CLEARANCE ABOVE THE FLOOR TO LIFT AND REMOVE THE T/R RIG ASSEMBLY FROM THE OIL TANK. CLEARANCE DOES NOT INCLUDE RIGGING HEIGHT.  
 6. POWERPLUS AND SWITCH ARE SEALED, RATED NEMA 4/IP56.

- BALLOONED NUMBERS:**
- 1 POWERPLUS UNIT.
  - 2 ROUND BOTTOM EXIT GROUND SWITCH.
  - 3 RATINGS NAMEPLATE, ALUMINUM PHOTO ETCHED.
  - 4 ACCESS DOOR TO POWER ELECTRONICS SECTION. ALLOW 19" [483] OF CLEARANCE FROM THIS FACE FOR DOOR SWING.
  - 5 ACCESS DOOR TO SWITCHGEAR AND CONTROL SECTION. ALLOW 37" [940] OF CLEARANCE FROM THIS FACE FOR DOOR SWING.
  - 6 INPUT CIRCUIT BREAKER SWITCH HANDLE W/ INTERLOCK PROVISION INSIDE. SEE DWG C140616.
  - 7 1" [25.4] DIA. CONDUIT HOLE FOR 120V CONTROL WIRING.
  - 8 1/2" [12.7] DIA. CONDUIT HOLE FOR LOW VOLTAGE TRANSDUCER AND COMMUNICATION LINK CONDUIT.
  - 9 2" [51] DIA. CONDUIT HOLE FOR 3 PHASE POWER AND GROUND.
  - 10 COOLING FAN FOR IGBT HEATSINK ASSEMBLY.
  - 11 WEATHER TIGHT, RJ45 CONNECTOR FOR NWL HMI CONNECTION.
  - 12 LIFTING HOOKS (4 PLACES).
  - 13 H.V. SWITCH MECHANISM W/ VIEWING WINDOW AND INTERLOCK PROVISIONS. SEE DWG A105811.
  - 14 SIDE EXIT 18" DUCT MOUNTING PROVISION. INCLUDES GASKETS AND 3/8-16 HARDWARE, (8) PLACES ON A 20" [508] DIA. WITH 18" [457] DIA. DUCT OPENING.
  - 15 S.S. GROUND CABLE TO GROUND EACH SECTION, INCLUDING ACCESS COVERS.
  - 16 HIGH VOLTAGE SEMI-OUTDOOR BUSHING, SEE DETAIL 'A'.
  - 17 OPTIONAL METRIC ADAPTER FOR H.V. BUSHING CONNECTION. CONVERTS 1/2" NPT TO M20-1.5. SEE DWG A117570.
  - 18 EQUIPMENT SAFETY GROUND TERMINATION, 3/8-16 GROUND BOSS.
  - 19 OPTIONAL SUN SHIELD MUST BE SHIPPED SEPARATELY AND INSTALLED IN THE FIELD.

ALL DIMENSIONS IN INCHES [mm]

<b>NWL</b> 312 RISING SUN RD BORDENTOWN, NJ 08505 TEL. (609) 298-7300 FAX. (609) 298-1982		
TITLE: HF ESP, POWERPLUS SERIES 7, 28-35kW UNITS, w/ DISCONNECT SWITCH		
SCALE: N/A	APP'D BY: RJK	REVISION DATE: 01/29/18
DWG BY: KAF	D.E.: RJK	DWG: 28-35DS_S7
TOLERANCES: (UNLESS OTHERWISE SPECIFIED) ANGLES +/- 5 DEG DECIMALS: .XX +/- 0.05 FRACTIONS: +/- 3/16		NWL PROPRIETARY INFORMATION, NOT TO BE REPRODUCED WITHOUT WRITTEN CONSENT

8 7 6 5 4 3 2 1