

DETAIL A
SCALE 1 / 7

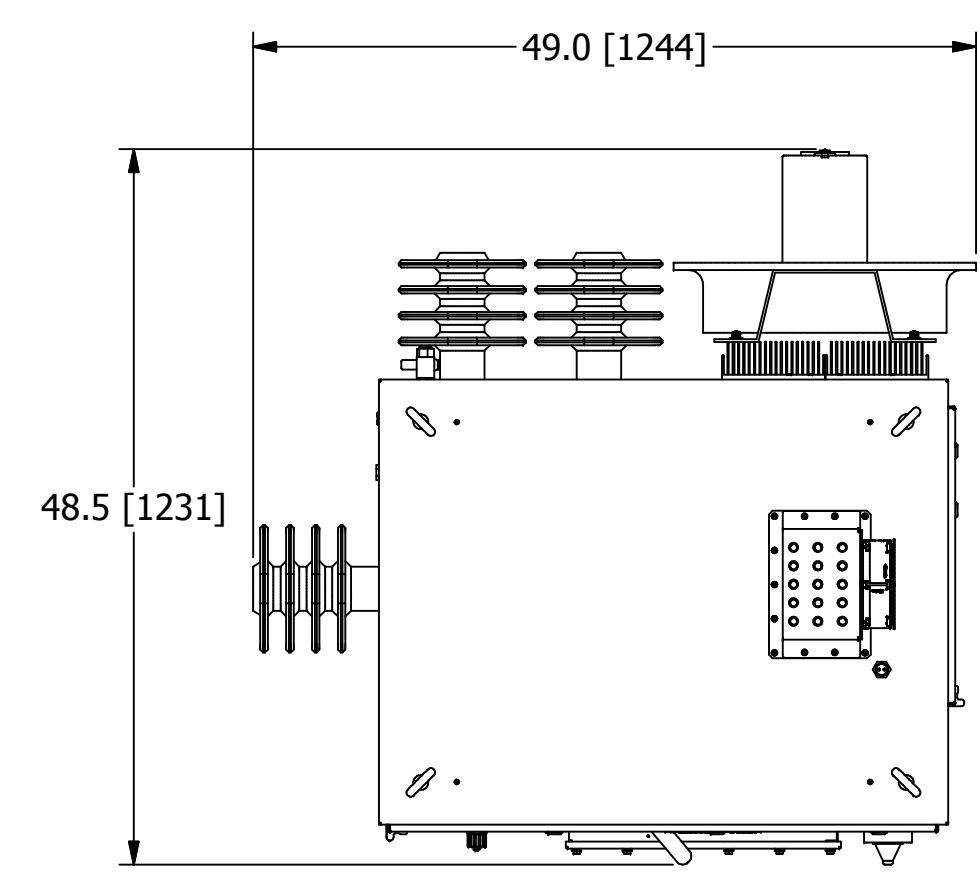

TOP

3 PHASE CIRCUIT BREAKER PER DWG ESPELECT-06
TABS TO ACCEPT 3/8" LUGS, TORQUE TO 80in-lbs.

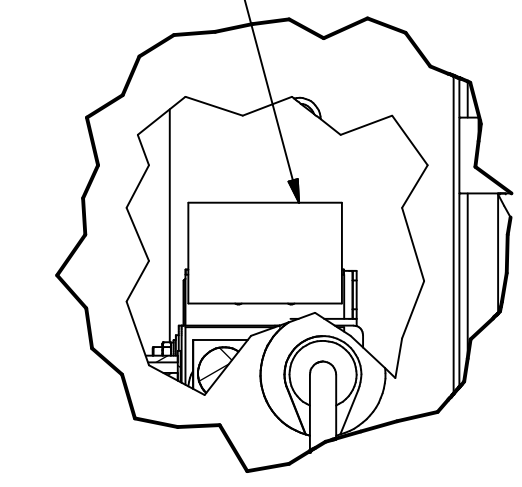

DETAIL C
CIRCUIT BREAKER DETAIL
SCALE 1 / 5

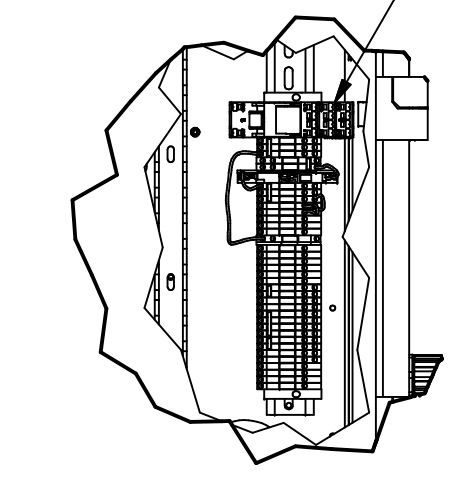

DETAIL D
'2TB' TERMINAL BLOCK RAIL ASSY
SCALE 1/6

FOR DETAILS REFER TO
DWG ESPELECT-06

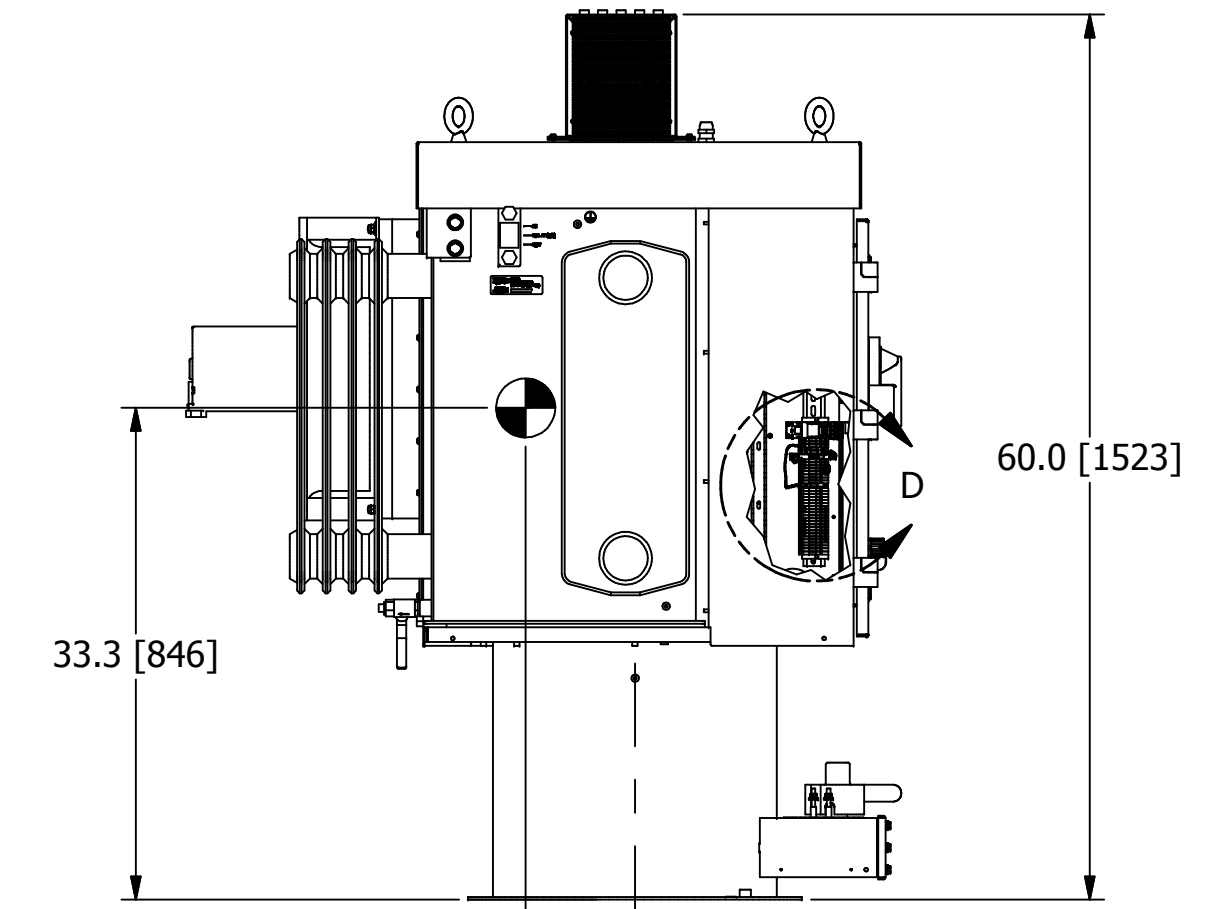
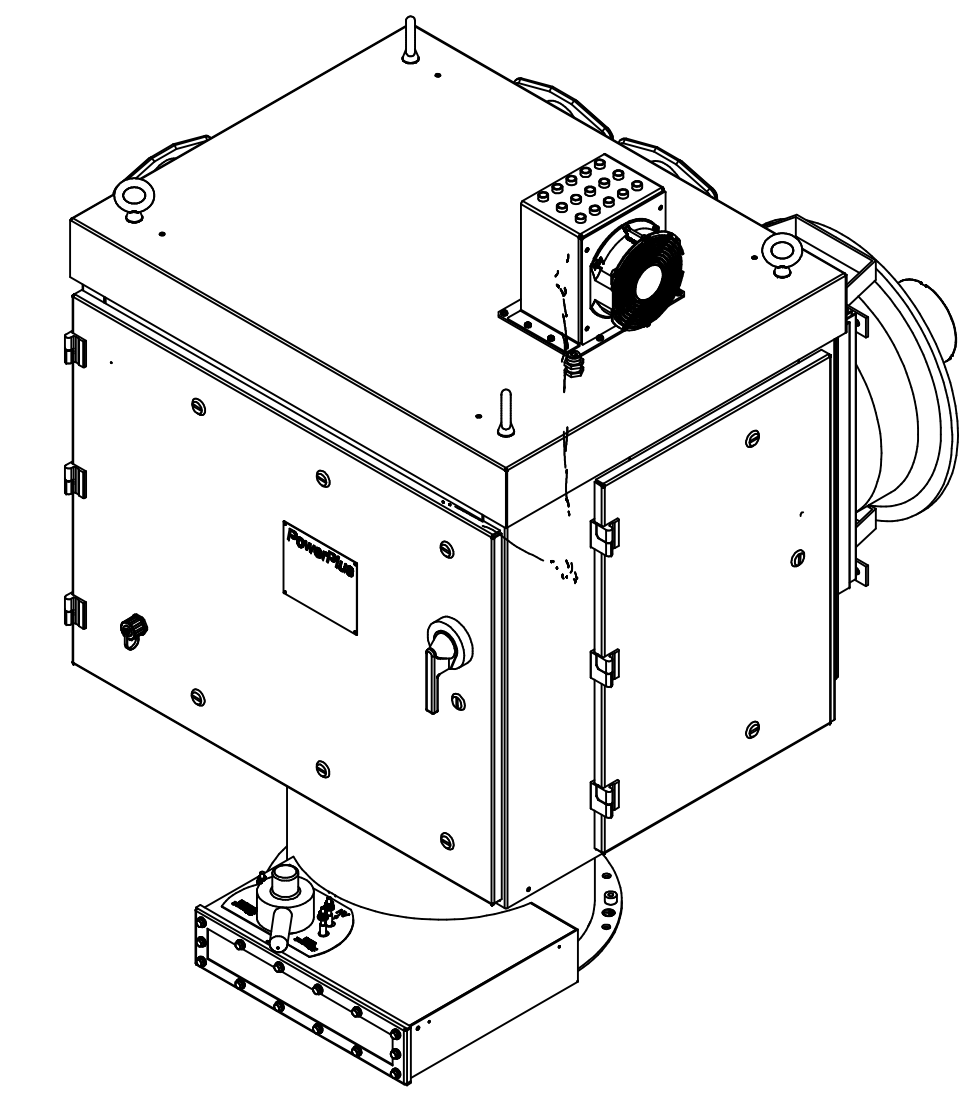

LEFT SIDE

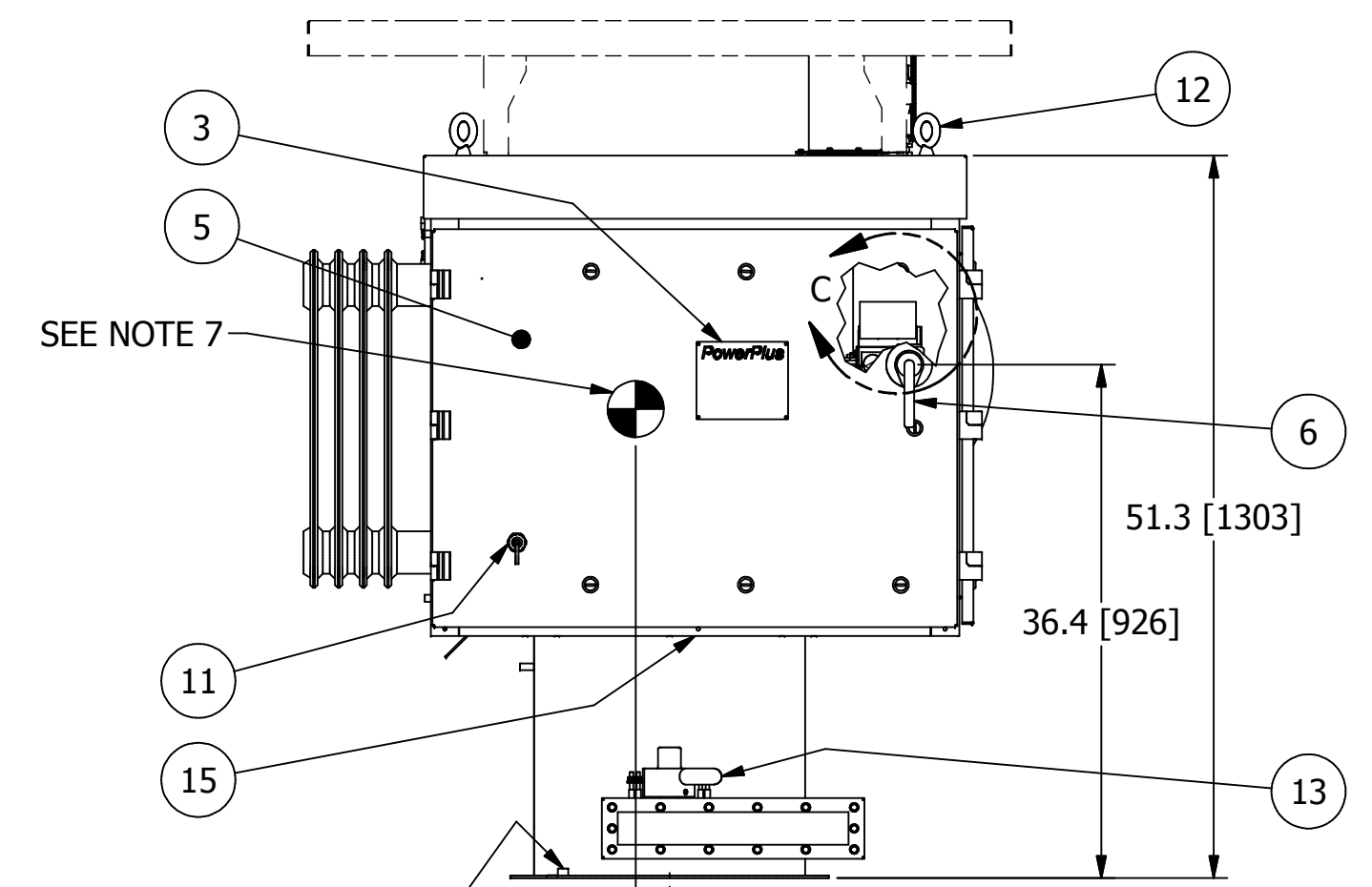

FRONT

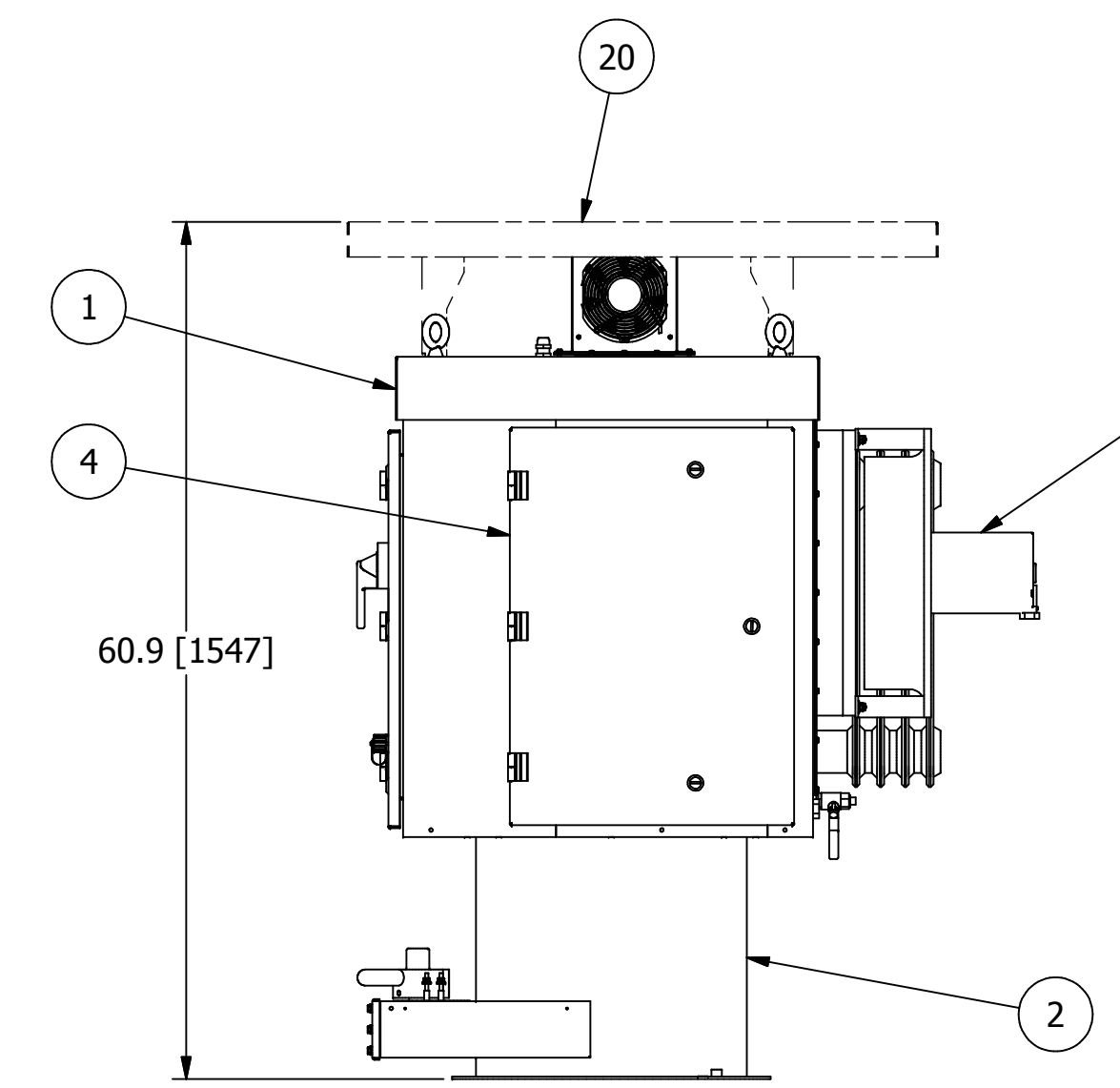

RIGHT SIDE

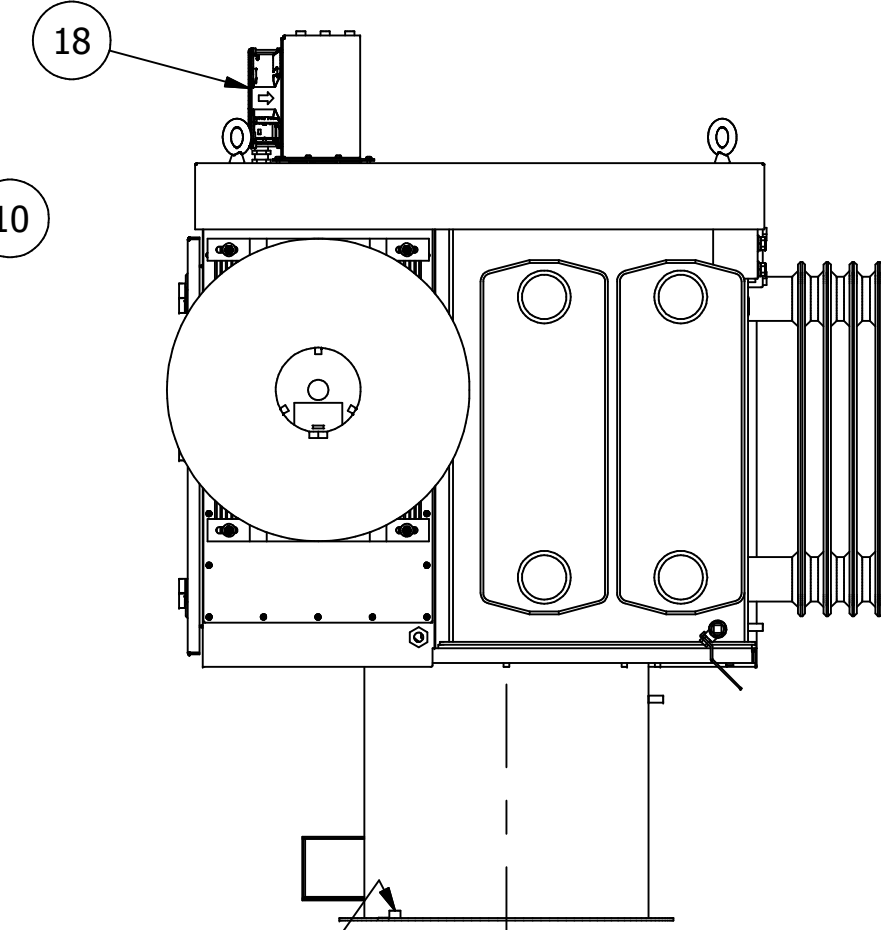

BACK

BALLOONED NUMBERS:

- ① POWERPLUS UNIT.
- ② ROUND BOTTOM EXIT GROUND SWITCH.
- ③ RATINGS NAMEPLATE, ALUMINUM PHOTO ETCHED.
- ④ ACCESS DOOR TO POWER ELECTRONICS SECTION. ALLOW 19" [483] OF CLEARANCE FROM THIS FACE FOR DOOR SWING.
- ⑤ ACCESS DOOR TO SWITCHGEAR AND CONTROL SECTION. ALLOW 37" [940] OF CLEARANCE FROM THIS FACE FOR DOOR SWING.
- ⑥ INPUT CIRCUIT BREAKER SWITCH HANDLE W/ INTERLOCK PROVISION INSIDE. SEE DWG C140616.
- ⑦ 1" [25.4] DIA. CONDUIT HOLE FOR 120V CONTROL WIRING.
- ⑧ 1/2" [12.7] DIA. CONDUIT HOLE FOR LOW VOLTAGE TRANSDUCER AND COMMUNICATION LINK CONDUIT.
- ⑨ 2" [51] DIA. CONDUIT HOLE FOR 3 PHASE POWER AND GROUND.
- ⑩ COOLING FAN FOR IGBT HEATSINK ASSEMBLY.
- ⑪ WEATHER TIGHT, RJ45 CONNECTOR FOR NWL HMI CONNECTION.
- ⑫ LIFTING EYES (4 PLACES).
- ⑬ H.V. SWITCH MECHANISM W/ VIEWING WINDOW AND INTERLOCK PROVISIONS. SEE DWG A105811.
- ⑭ BOTTOM EXIT DUCT FLANGE, 22.63" [575] O.D. X 19.00" [483] I.D. w/ (12) 0.50" [12.7] DIA. HOLES EQUALLY SPACED ON A 21.44" [545] DIA. BOLT CIRCLE (GASKET NOT INCLUDED).
- ⑮ S.S. GROUND CABLE TO GROUND EACH SECTION, INCLUDING ACCESS COVERS.
- ⑯ HIGH VOLTAGE SEMI-OUTDOOR BUSHING, SEE DETAIL 'A'.
- ⑰ OPTIONAL METRIC ADAPTER FOR H.V. BUSHING CONNECTION. CONVERTS 1/2" NPT TO M20-1.5. SEE DWG A117570.
- ⑱ HEAT EXCHANGER ASSEMBLY.
- ⑲ EQUIPMENT SAFETY GROUND TERMINATION, 3/8-16 GROUND BOSS.
- ⑳ OPTIONAL SUN SHIELD MUST BE SHIPPED SEPARATELY AND INSTALLED IN THE FIELD.

SHIPPING NOTES:

1. POWERPLUS WILL BE SHIPPED WITH ROUND GROUND SWITCH.
2. POWERPLUS AND SWITCH COMBINED SHIPPING WEIGHT: 1100lbs [499kg]
3. GROUND SWITCH SHIPPING WEIGHT: 75lbs [35kg]
4. DIELECTRIC FLUID VOLUME: 29gal [110L]
5. FINISH: ENAMEL, ASA 61, APPROX. RAL 7042.
6. INDICATES CENTER OF GRAVITY.

INSTALLATION NOTES:

1. POWERPLUS MUST BE MOUNTED ON LEVEL SURFACE OR SHIMMED TO WITHIN 1/8" [3.2] RISE PER 12" [305] RUN.
2. MAXIMUM FLOOR LOADING: 305lbs/sq.ft [1489kgs/sq.m]
3. COLD ROOF MAY NEED TO BE REINFORCED TO ACCEPT THE WEIGHT OF THE POWERPLUS UNIT.
4. MAXIMUM ALLOWABLE DUCT INTERNAL TEMPERATURE: 122°F (50°C). MAXIMUM ALLOWABLE DUCT INTERNAL PRESSURE: 1 PSI (2.04" Hg). THE INSTALLER MUST USE AN ENTRANCE BUSHING IN ROOF TO MEET THESE SPECIFICATIONS.
5. POWERPLUS MUST BE GROUNDED TO THE COLD ROOF BY THE END USER. REFER TO DWG B126972 FOR GROUNDING DETAILS.
6. ALLOW 120" MINIMUM CLEARANCE ABOVE THE FLOOR TO LIFT AND REMOVE THE T/R RIG ASSEMBLY FROM THE OIL TANK. CLEARANCE DOES NOT INCLUDE RIGGING HEIGHT.
7. POWERPLUS AND SWITCH ARE SEALED, RATED NEMA 4/IP56.

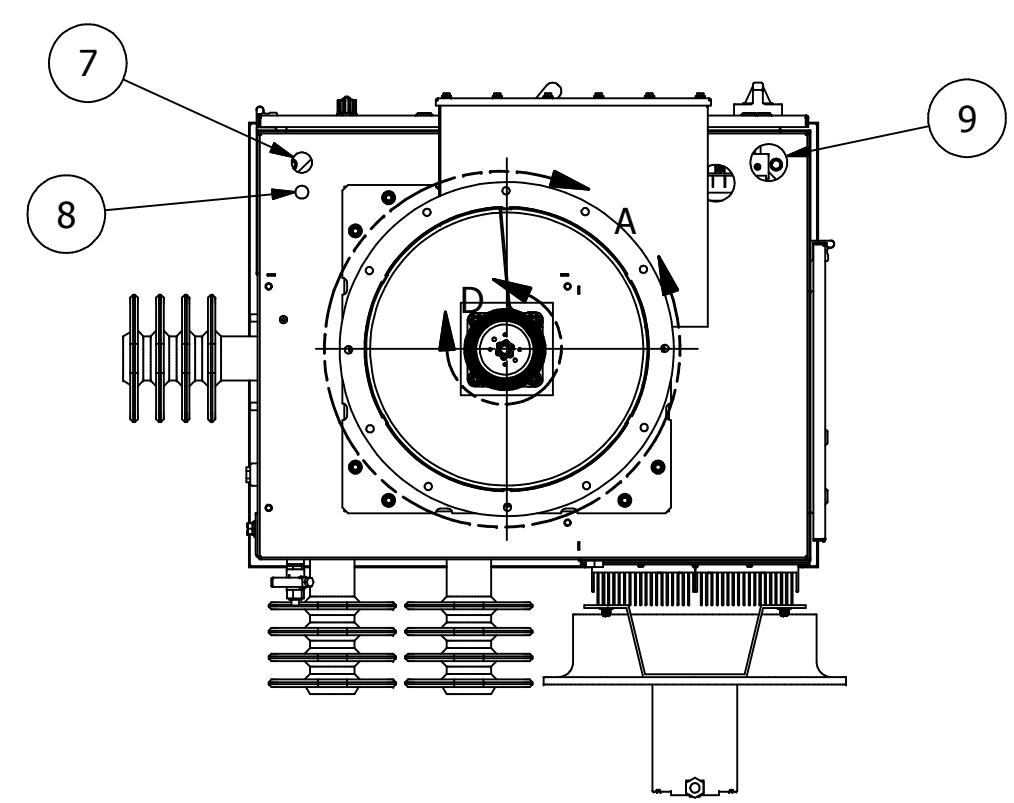

BOTTOM

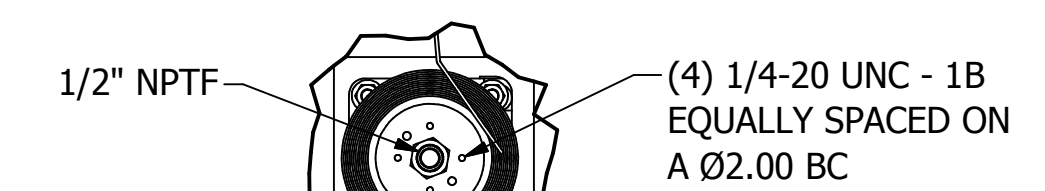

DETAIL D
SCALE 1 / 6

ALL DIMENSIONS IN INCHES [mm]

NWL 312 RISING SUN RD BORDENTOWN, NJ 08505 TEL. (609) 298-7300 FAX. (609) 298-1982		
TITLE: HF ESP, POWERPLUS SERIES 7, 45-70kW UNITS, w/ ROUND GROUND SWITCH		
SCALE: N/A	APP'D BY: RJK	REVISION DATE: 01/29/18
DWG BY: KAF	D.E.: RJK	DWG: 45-70RD_S7
TOLERANCES: (UNLESS OTHERWISE SPECIFIED) ANGLES +/- 5 DEG DECIMALS: XX +/- 0.05 FRACTIONS: +/- 3/16		NWL PROPRIETARY INFORMATION, NOT TO BE REPRODUCED WITHOUT WRITTEN CONSENT