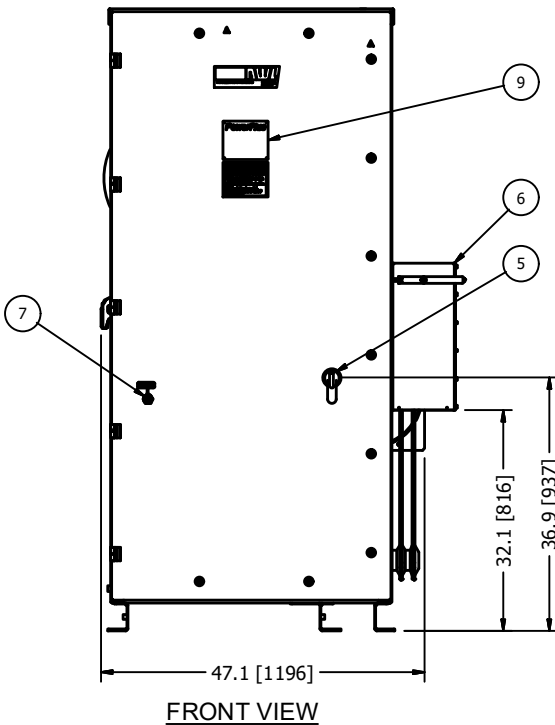
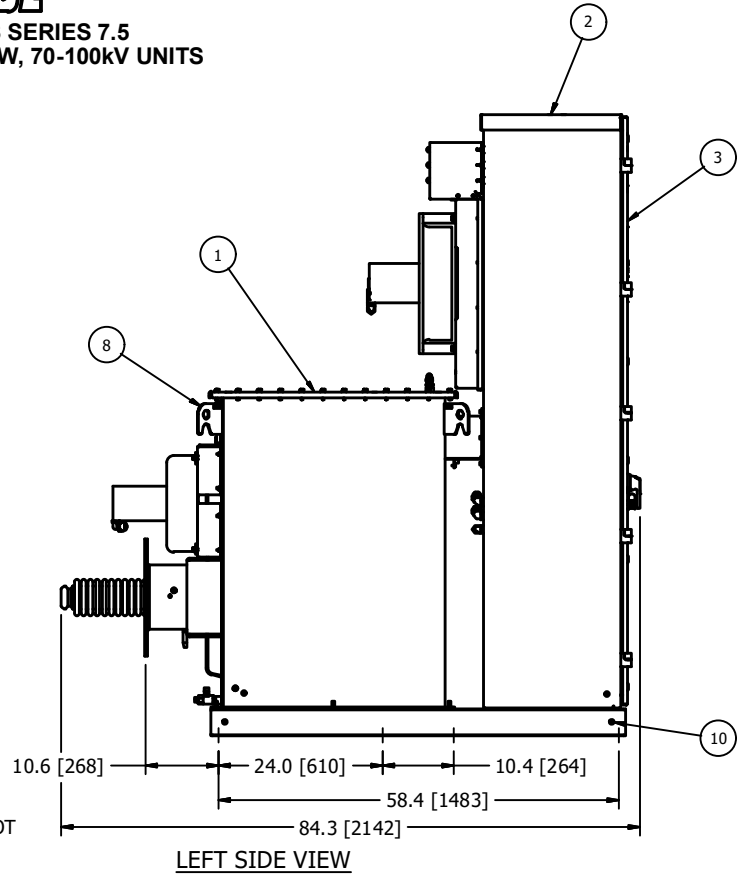
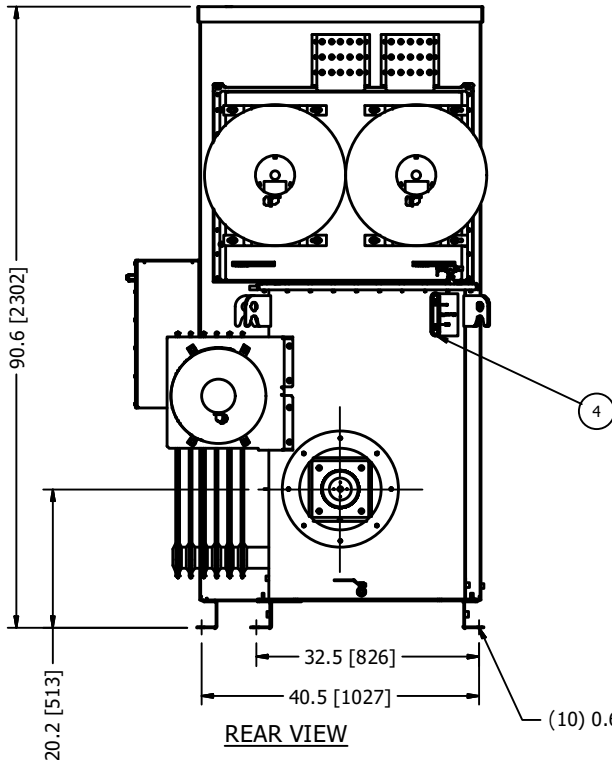

2

1

NWL**POWERPLUS SERIES 7.5**
480VAC, 160 & 200kW, 70-100kV UNITS

- ① POWERPLUS H.V. TANK
- ② POWERPLUS CONTROLLER UNIT.
- ③ ACCESS DOOR TO CIRCUIT BREAKER TERMINALS, FUSES AND 3 PHASE RECTIFIERS. ALLOW 42" [1067] OF CLEARANCE FROM THIS FACE FOR DOOR SWING.
- ④ LIQUID LEVEL GAUGE AND TEMPERATURE GAUGE FOR OIL TANK
- ⑤ INPUT CIRCUIT BREAKER SWITCH HANDLE WITH INTERLOCK PROVISION INSIDE. FOR ACCEPTABLE INTERLOCKS SEE DWG C140616.
- ⑥ AC INPUT ENTRY JUNCTION BOX.
- ⑦ WEATHER TIGHT, RJ45 CONNECTOR FOR NWL HMI CONNECTION.
- ⑧ LIFTING HOOKS (4 PLACES).
- ⑨ RATINGS NAMEPLATE, ALUMINUM PHOTO ETCHED.
- ⑩ EQUIPMENT SAFETY GROUND TERMINATION, 3/8-16 GROUND BOSS.

ELECTRICAL SPECIFICATIONS

kW	kVA	Input Voltage 3Ø, 50/60 Hz, ±10%	Output Current mADC	Output Voltage kVDC	Rated Input Current Amps	Circuit Breaker Rating Amps	Losses kW
160	180	480	1600	100	216	300	8.4
200	224	480	2860 / 2410	70 / 83	269	400	10.5
200	224	480	2000	100	269	400	10.5

Min. Ambient Temp.	Max. Avg. Ambient Temp. (24 hr)	Max. Ambient Temp.
-20°C	40°C	50°C for up to 4 hours over a 24 hour period

EXPORT CRATE DIMENSIONS: 92 (2337mm)L x 48 (1219mm)W x 96 (2438mm)H.
 EXPORT CRATE WEIGHT: 4100lbs (1860kg).
 MAXIMUM FLOOR LOADING: 250lbs/sq.ft (1221kgs/sq.m).
 DIELECTRIC FLUID VOLUME: 145 gal (549L).
 FINISH: ENAMEL, ASA 61, APPROX. RAL 7042.
 TANK AND CONTROL ENCLOSURE RATED NEMA 4/IP56.

DATA SHEET: 480_200_100_S7.5-B
 REVISION DATE: 08/19/20
 APPROVED BY: RJK

ALL DIMENSIONS IN INCHES [mm]