

DETAIL A
SCALE 1/7

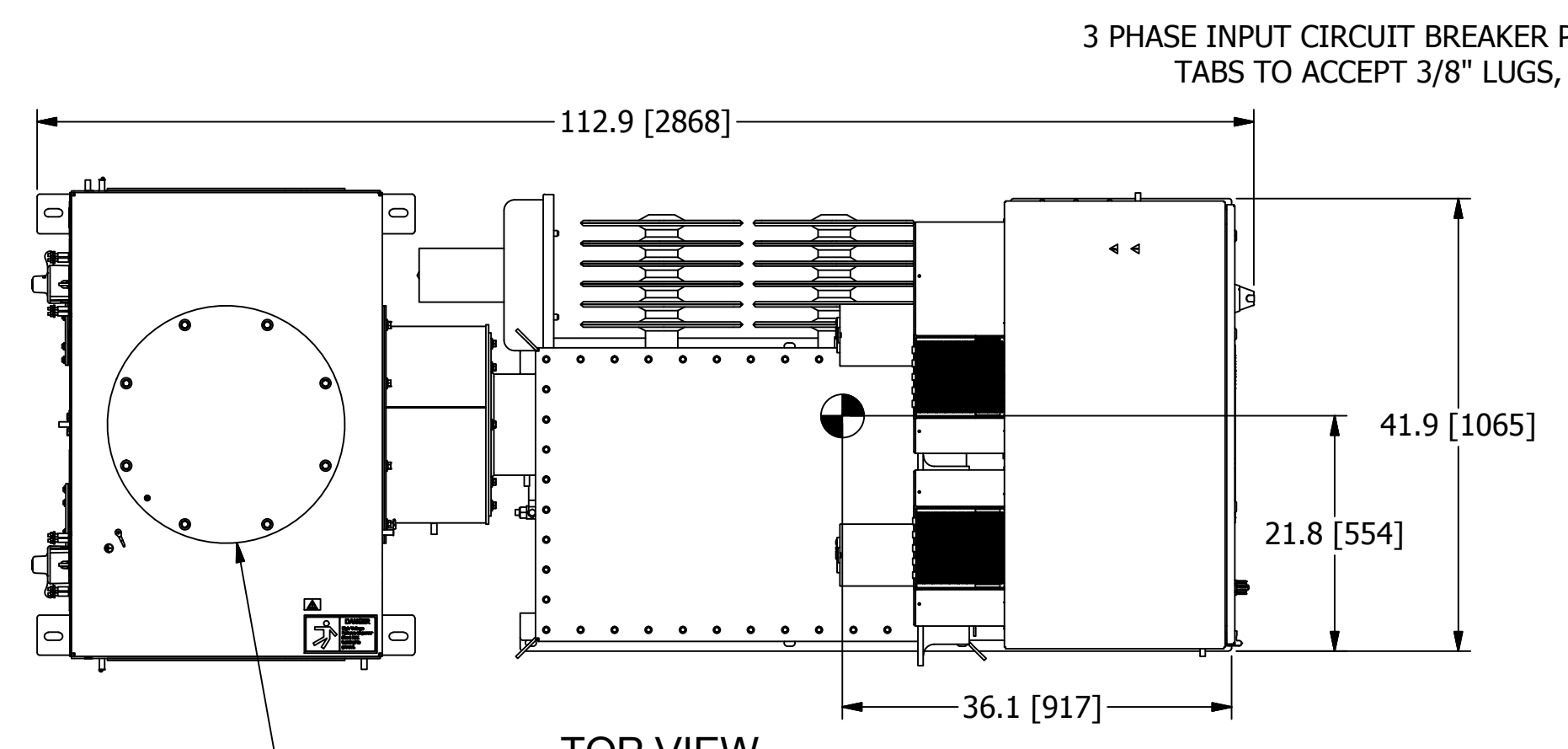

TOP VIEW

3 PHASE INPUT CIRCUIT BREAKER PER DWG ESPELECT-06
TABS TO ACCEPT 3/8" LUGS, TORQUE TO 252in-lbs.

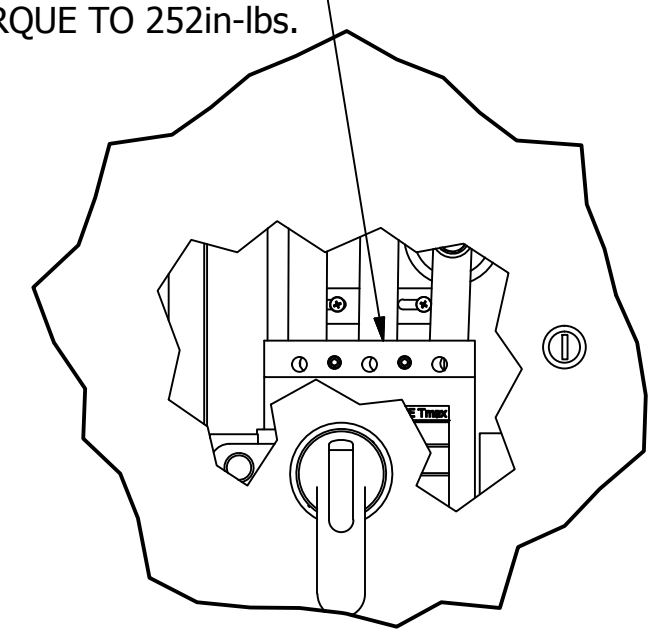

DETAIL C
SCALE 1/5
CIRCUIT BREAKER DETAIL

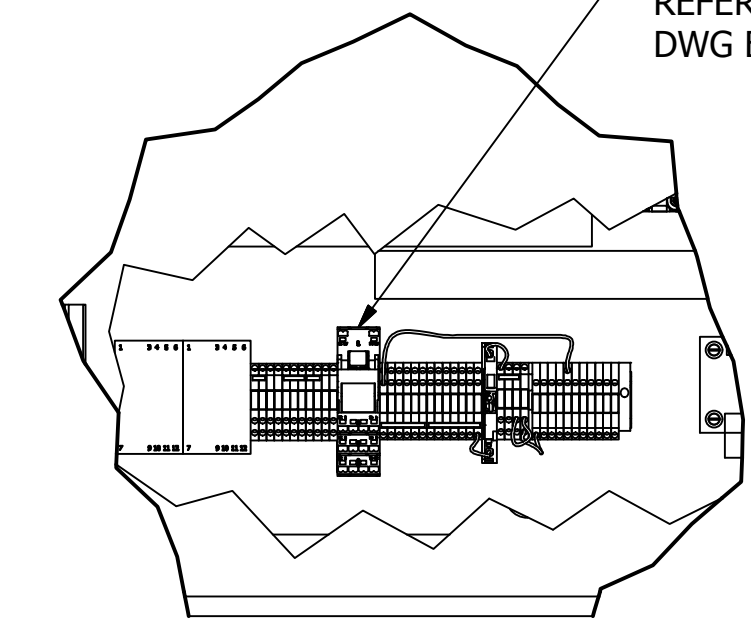

DETAIL D
SCALE 1/5
'2TB' TERMINAL BLOCK RAIL ASSEMBLY

FOR DETAILS
REFER TO
DWG ESPELECT-06

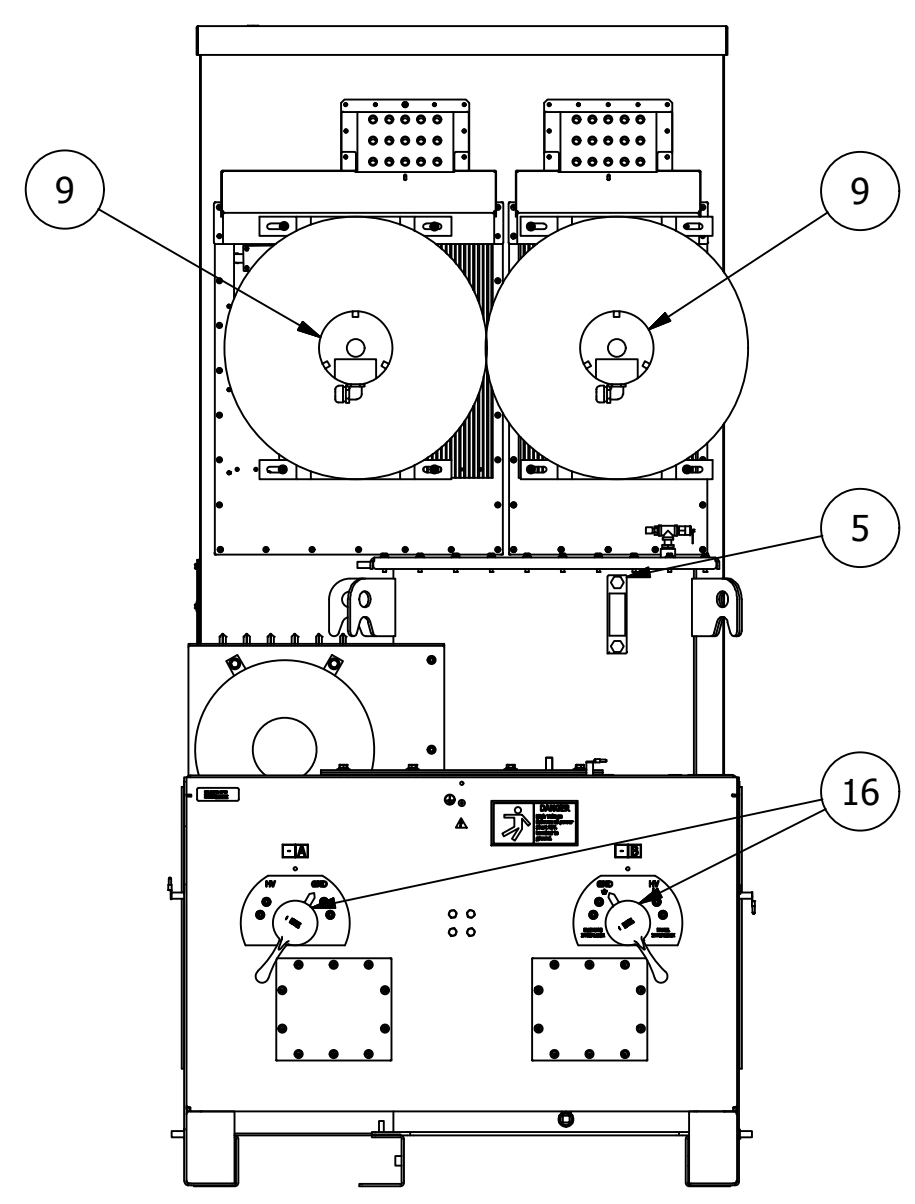
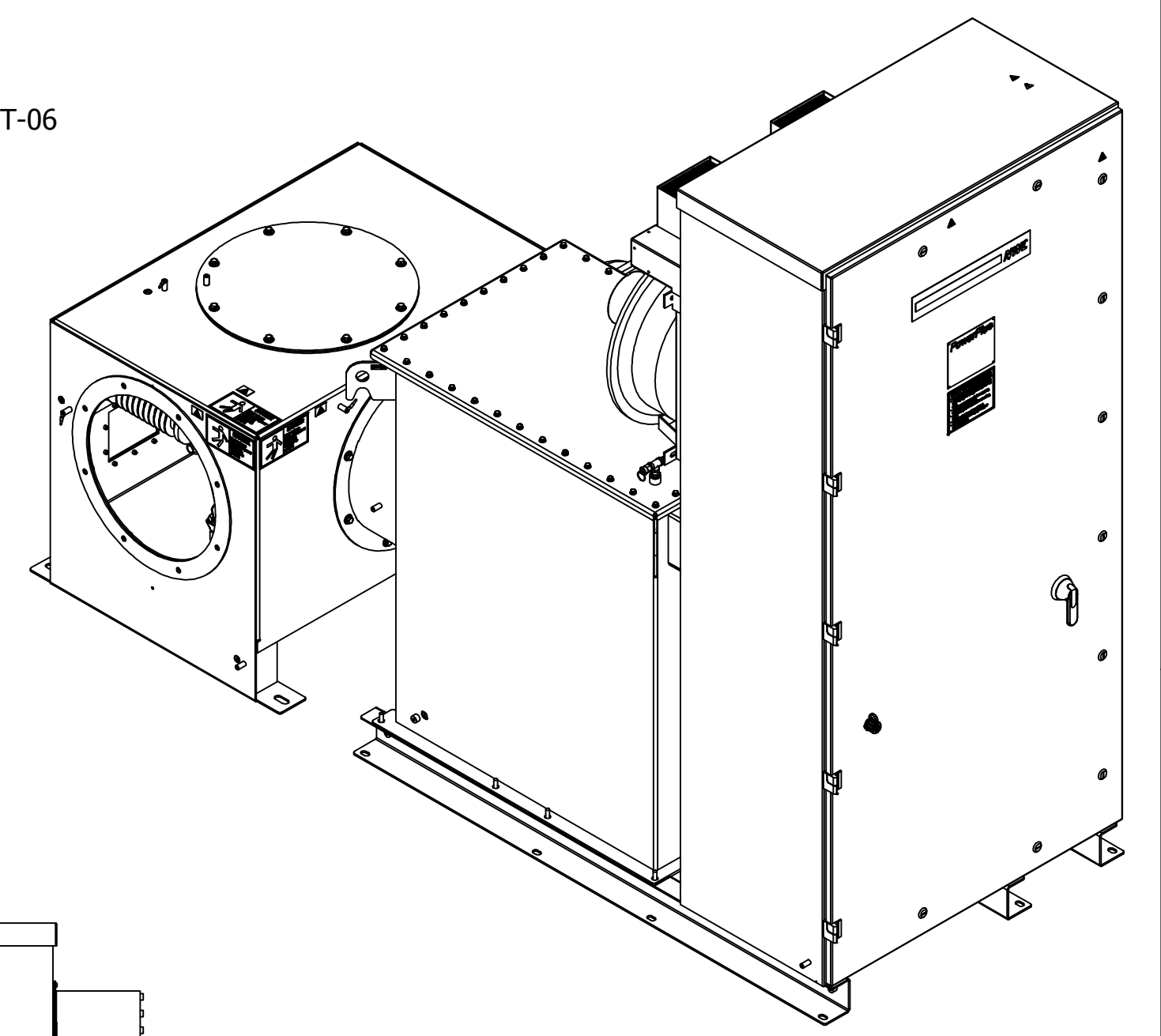

REAR VIEW

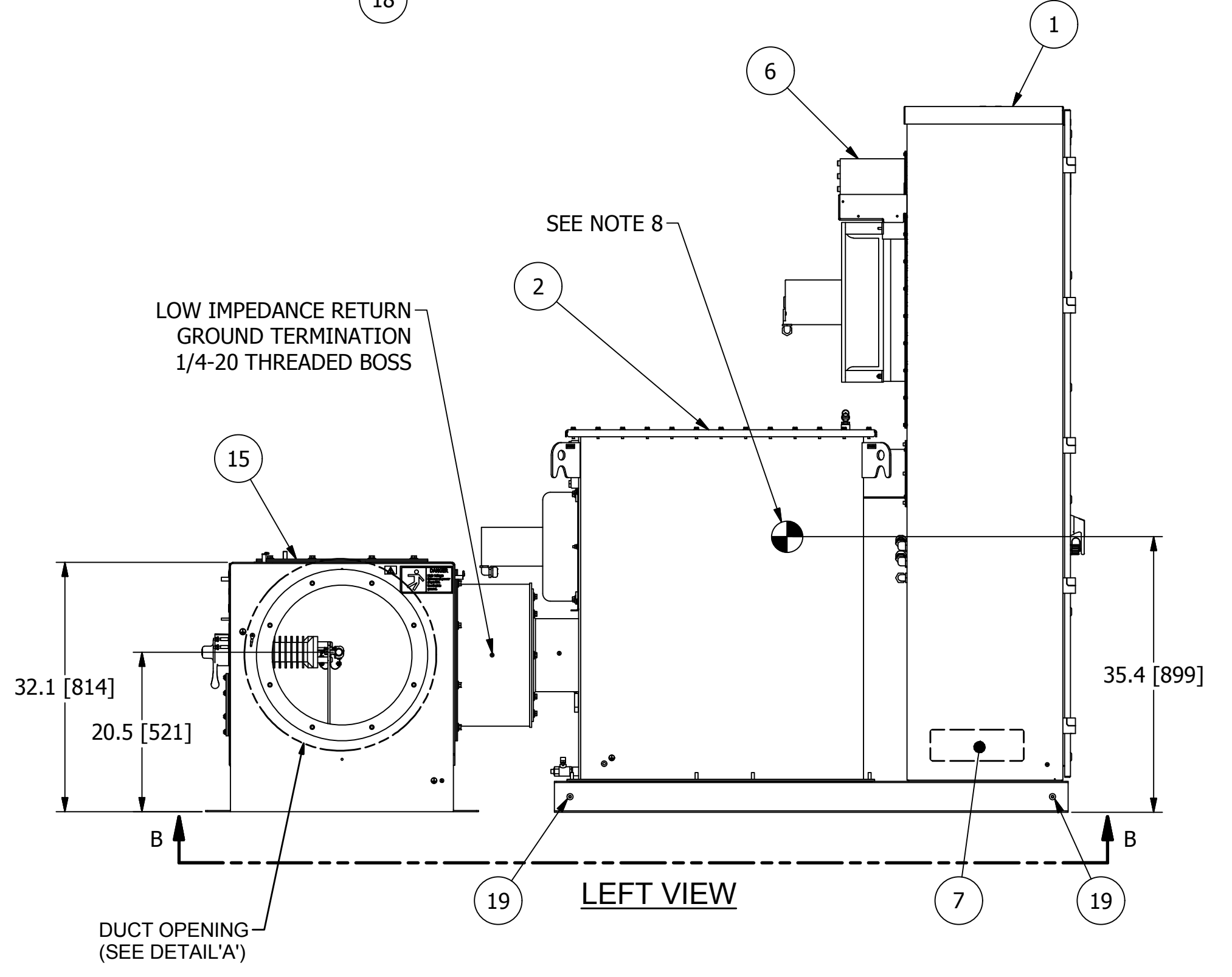

LEFT VIEW

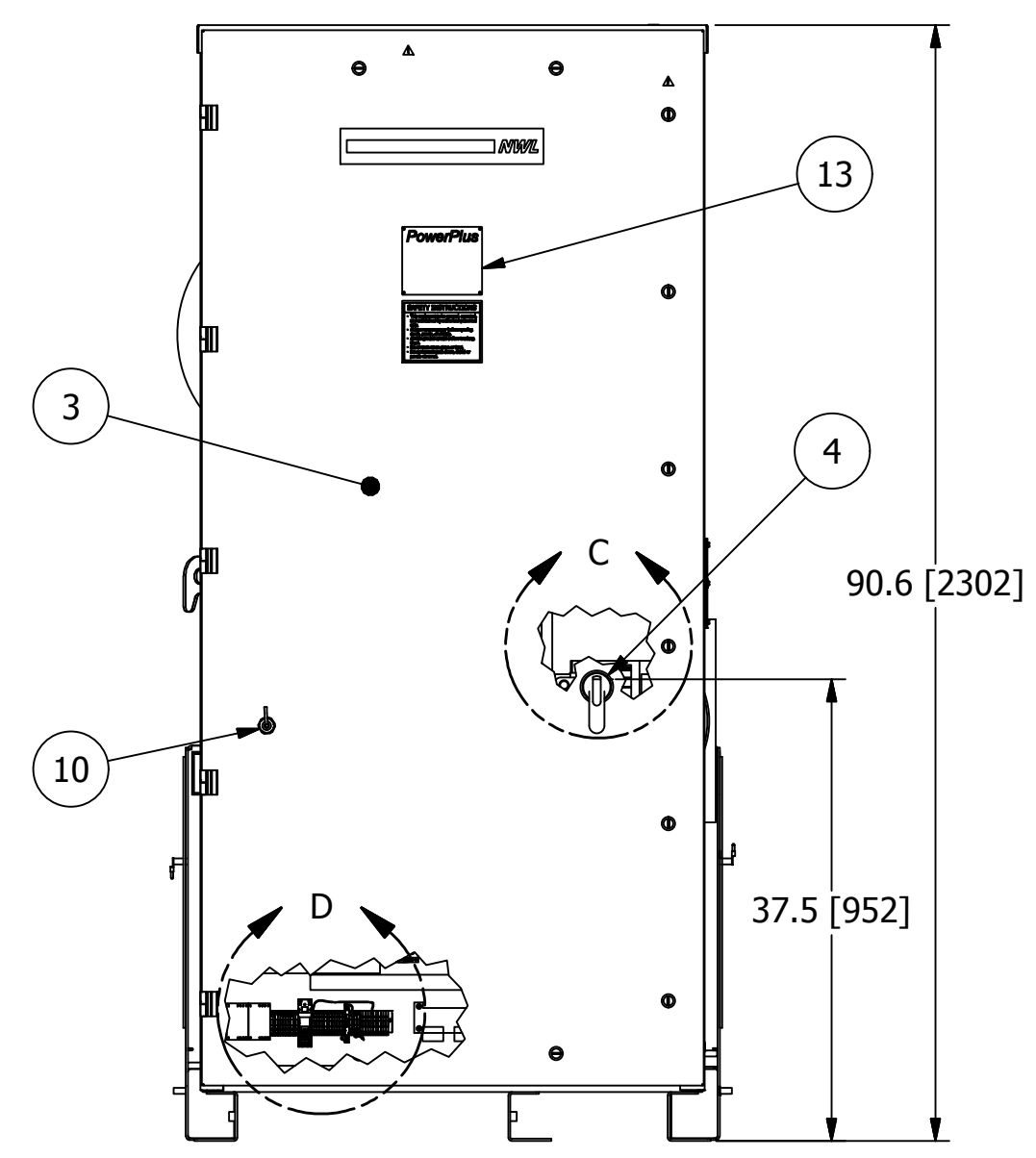

FRONT VIEW

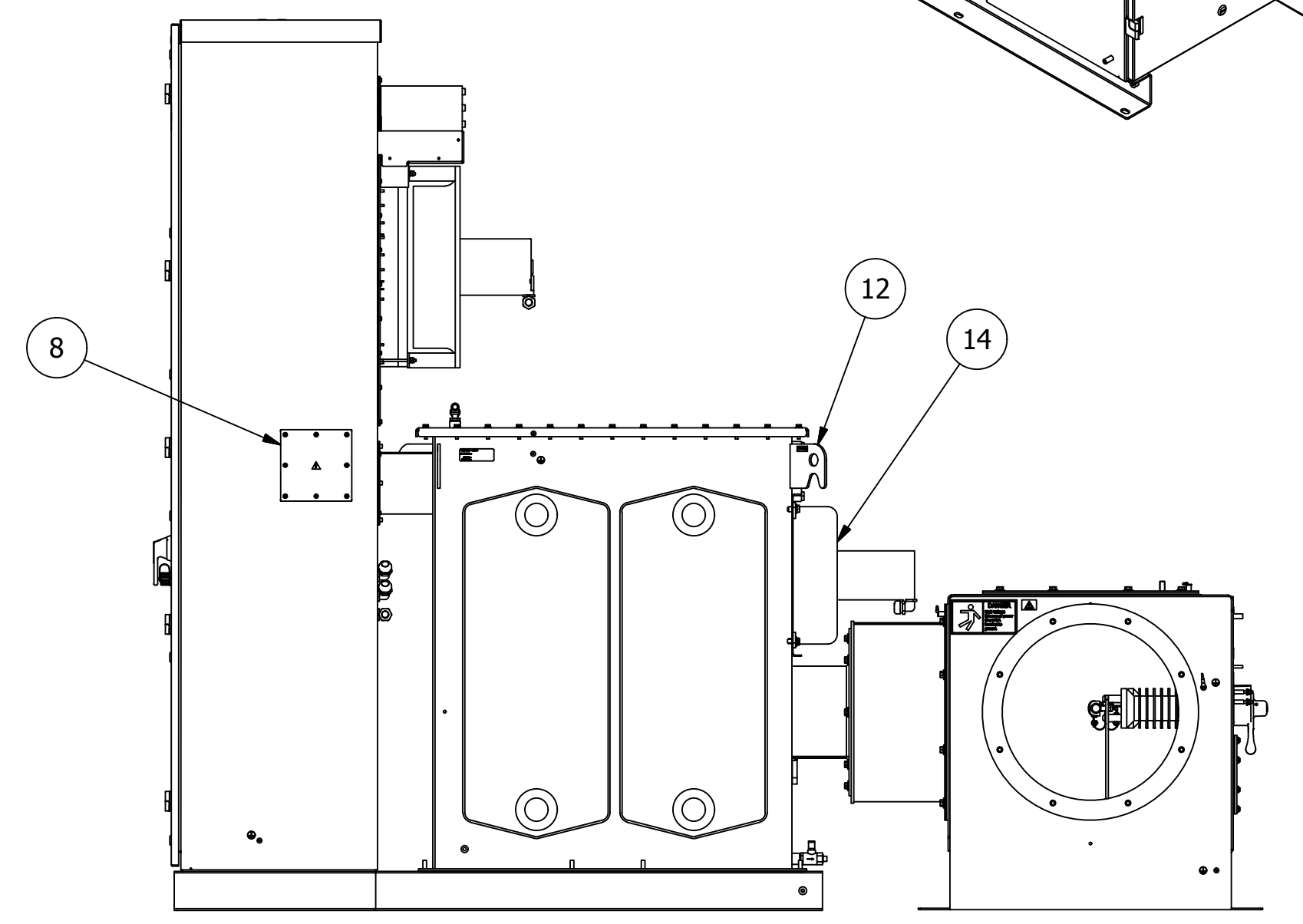

RIGHT VIEW

SHIPPING NOTES:
 1. POWERPLUS WILL BE SHIPPED SEPARATELY.
 2. SPLITTER SWITCH MUST BE SHIPPED SEPARATELY AND INSTALLED IN THE FIELD.
 3. SPLITTER SWITCH WILL BE SHIPPED WITH DUCT GASKET AND MOUNTING HARDWARE.
 4. POWERPLUS SHIPPED WEIGHT: 3400lbs [1543kg]
 5. SPLITTER SWITCH SHIPPED WEIGHT: 350lbs [159kg]
 6. DIELECTRIC FLUID VOLUME: 134gal [507L]
 7. FINISH: ENAMEL, ASA 61, APPROX. RAL 7042.
 8. INDICATES CENTER OF GRAVITY

INSTALLATION NOTES:
 1. POWERPLUS MUST BE MOUNTED ON LEVEL SURFACE OR SHIMMED TO WITHIN 1/8" [3.2] RISE PER 12" [305] RUN.
 2. COLD ROOF MAY NEED TO BE REINFORCED TO ACCEPT THE WEIGHT OF THE POWERPLUS UNIT.
 3. MAXIMUM ALLOWABLE DUCT INTERNAL TEMPERATURE: 122°F (50°C). MAXIMUM ALLOWABLE DUCT INTERNAL PRESSURE: 1 PSI (2.04" Hg). THE INSTALLER MUST USE AN ENTRANCE BUSHING IN ROOF TO MEET THESE SPECIFICATIONS.
 4. POWERPLUS MUST BE GROUNDED TO THE COLD ROOF BY THE END USER. REFER TO DWG B126972 FOR GROUNDING DETAILS.
 5. ALLOW 100" MINIMUM CLEARANCE ABOVE THE FLOOR TO LIFT AND REMOVE THE T/R RIG ASSEMBLY FROM THE OIL TANK. CLEARANCE DOES NOT INCLUDE RIGGING HEIGHT.
 6. POWERPLUS AND SWITCH ARE SEALED, RATED NEMA 4/IP56.

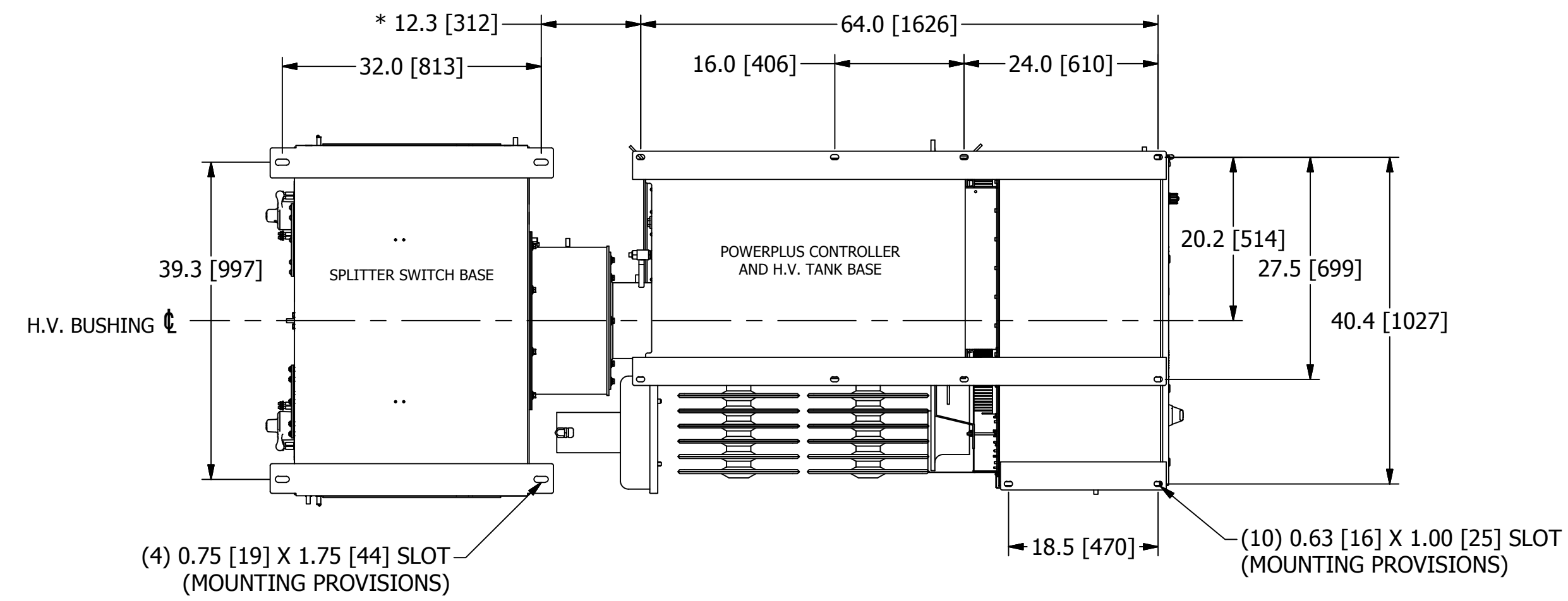

MOUNTING ARRANGEMENT FROM BOTTOM VIEW
(SECTION B-B)

* FOR REFERENCE ONLY. POWERPLUS AND SWITCH ASSEMBLY MUST BE FIELD FITTED TO THE H. V. DUCT WORK PRIOR TO SECURING TO ROOF.

BALLOONED NUMBERS:

- ① POWERPLUS CONTROLLER CABINET.
- ② POWERPLUS H.V. TANK.
- ③ ACCESS DOOR TO FUSE/CONTACTOR, 3 PHASE RECTIFIER ASSEMBLY AND CONTROL SECTION. ALLOW 42" [1067] OF CLEARANCE FROM THIS FACE FOR DOOR SWING.
- ④ INPUT CIRCUIT BREAKER SWITCH HANDLE W/ INTERLOCK PROVISION INSIDE. FOR ACCEPTABLE INTERLOCKS SEE DWG C140616.
- ⑤ LIQUID LEVEL GAUGE AND TEMPERATURE GAUGE FOR OIL TANK.
- ⑥ CONTROLLER HEAT EXCHANGER (2) PLACES.
- ⑦ RECOMMENDED CUSTOMER CONTROLS AND FEEDBACK CONDUIT LOCATION.
- ⑧ GLAND PLATE FOR 3 PHASE POWER AND GROUND.
- ⑨ COOLING FAN FOR IGBT HEATSINK ASSEMBLY (2) PLACES.
- ⑩ WEATHER TIGHT, RJ45 CONNECTOR FOR NWL HMI CONNECTION.
- ⑪ HIGH VOLTAGE SEMI-OUTDOOR BUSHING.
- ⑫ LIFTING HOOKS (4) PLACES.
- ⑬ RATINGS NAMEPLATE, ALUMINUM PHOTO ETCHED.
- ⑭ RADIATOR COOLING FAN.
- ⑮ SPLITTER GROUND SWITCH (SHIPS SEPARATELY).
- ⑯ H.V. SWITCH MECHANISM WITH VIEWING WINDOW AND INTERLOCK PROVISIONS. FOR INTERLOCK AND BOLT EXTENSION INFORMATION SEE DWG A105812.
- ⑰ SIDE EXIT 18" DUCT MOUNTING PROVISION. INCLUDES GASKETS AND 3/8-16 HARDWARE (8) PLACES ON A 20" [508] DIA B.C. WITH 18" [457] DIA DUCT OPENING.
- ⑱ SIDE EXIT 22" ACCESS COVER. INCLUDES GASKETS AND 3/8-16 HARDWARE (8) PLACES ON A 20" [508] DIA WITH 18" [457] DIA DUCT OPENING.
- ⑲ EQUIPMENT SAFETY GROUND TERMINATION, 3/8-16 GROUND BOSS.
- ⑳ OPTIONAL METRIC ADAPTER FOR H.V. BUSHING CONNECTION. CONVERTS 1/2" NPT TO M20-1.5. SEE DWG A117570.
- ㉑ 1/2" NPT OUTPUT CONNECTION.

ALL DIMENSIONS IN INCHES [mm]

NWL 312 RISING SUN RD BORDENTOWN, NJ 08505 TEL. (609) 298-7300 FAX. (609) 298-1982		
TITLE: HF ESP, POWERPLUS SERIES 7.5, 128-160KW UNITS, w/ SPLITTER SWITCH		
SCALE: N/A	APP'D BY: RJK	REVISION DATE: 2/15/19
DWG BY: SDE	D.E. RJK	DWG: 128-160SP_S7.5
<small> TOLERANCES: (UNLESS OTHERWISE SPECIFIED) ANGLES: +5 DEG DECIMALS: .XX +/- .005 FRACTIONS: +/- 3/16 DECIMALS: .XX +/- .005 DECIMALS: .XXX +/- .005 </small>		
<small> NWL PROPRIETARY INFORMATION. NOT TO BE REPRODUCED WITHOUT WRITTEN CONSENT. </small>		