

8 7 6 5 4 3 2 1

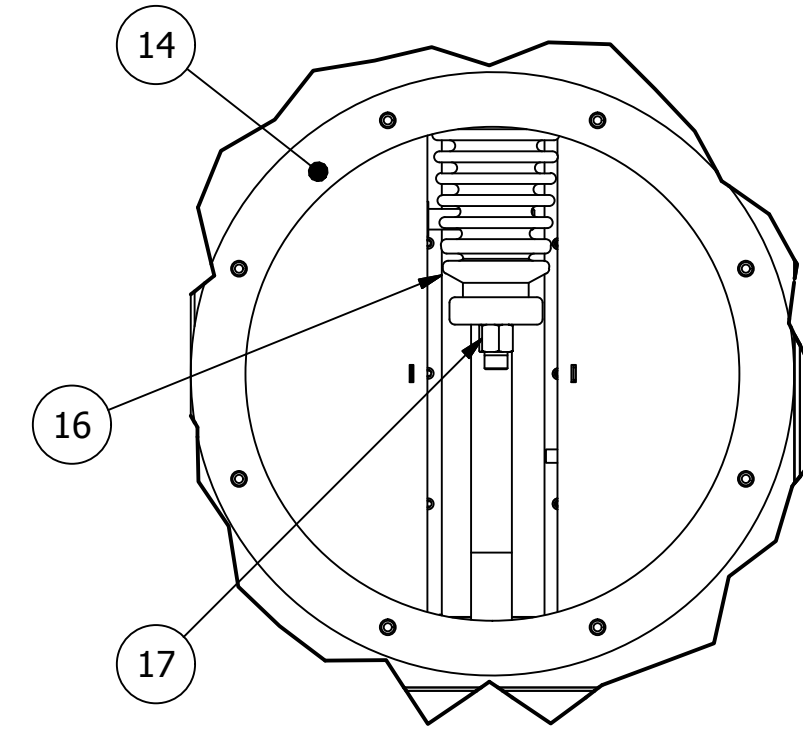

DETAIL A  
SCALE 1/7

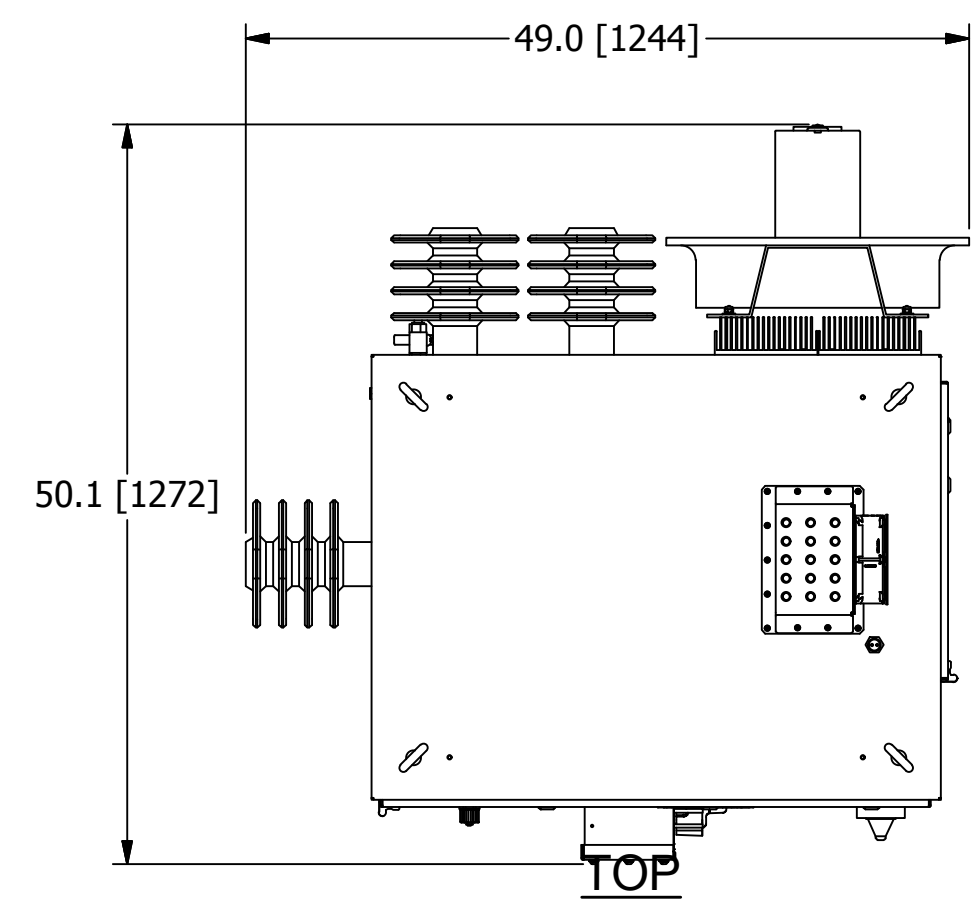

TOP

3 PHASE CIRCUIT BREAKER PER DWG ESPELECT-06  
TABS TO ACCEPT 3/8" LUGS, TORQUE TO 80in-lbs.

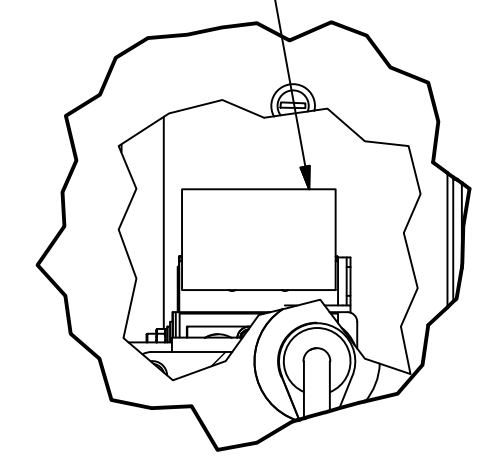

DETAIL C  
CIRCUIT BREAKER DETAIL  
SCALE 1/5

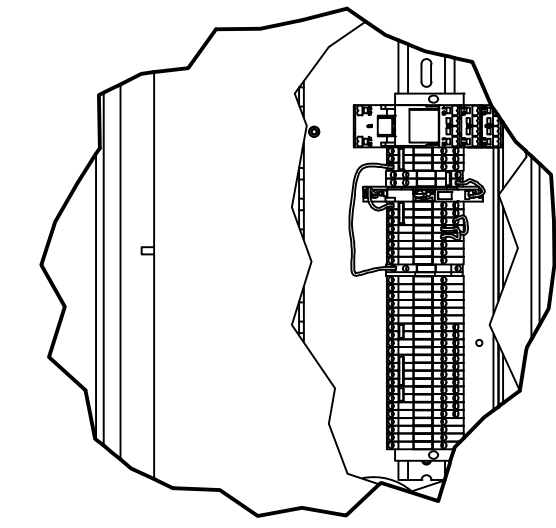

DETAIL D  
'2TB' TERMINAL BLOCK RAIL ASSY  
SCALE 1/5

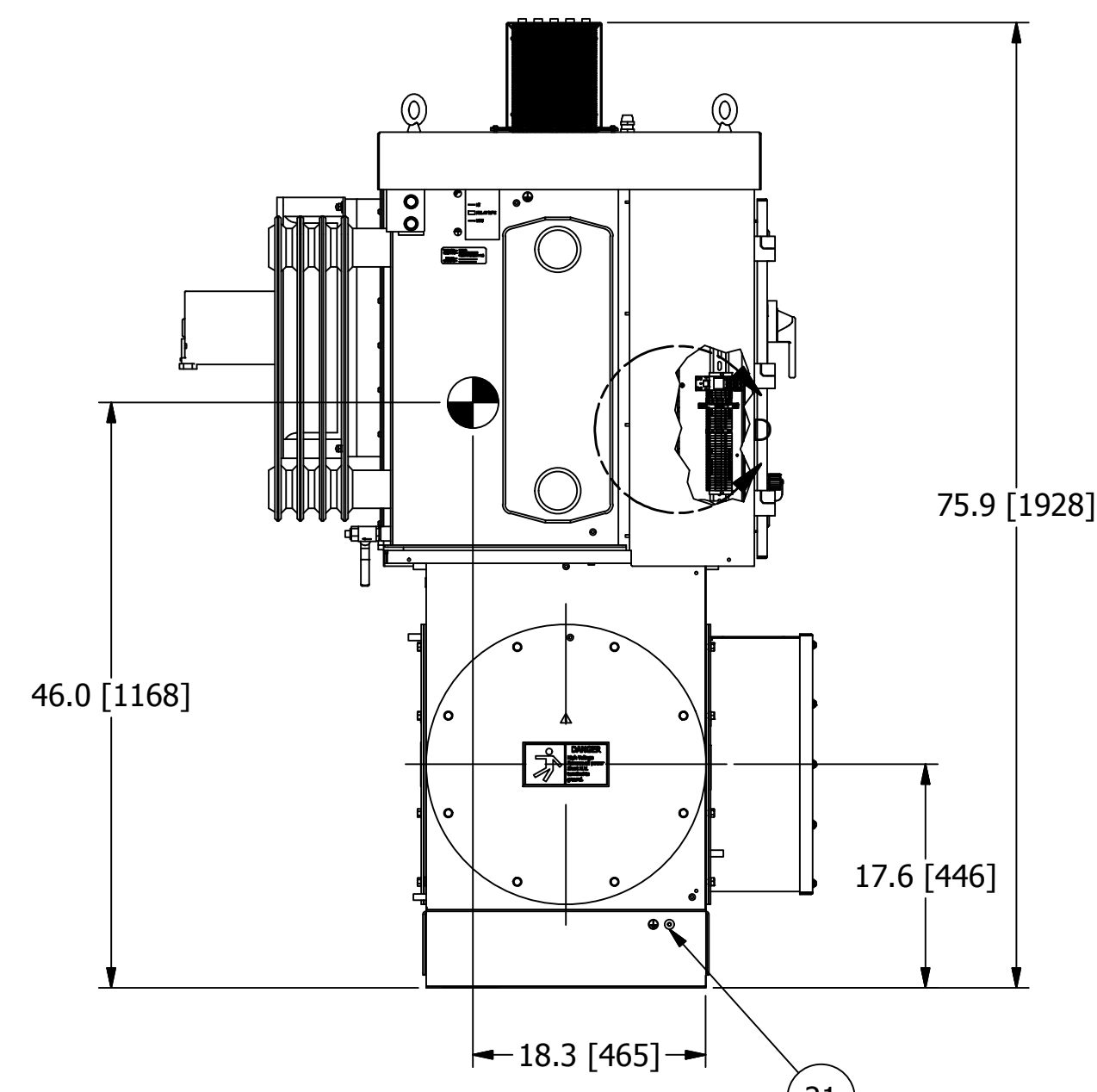
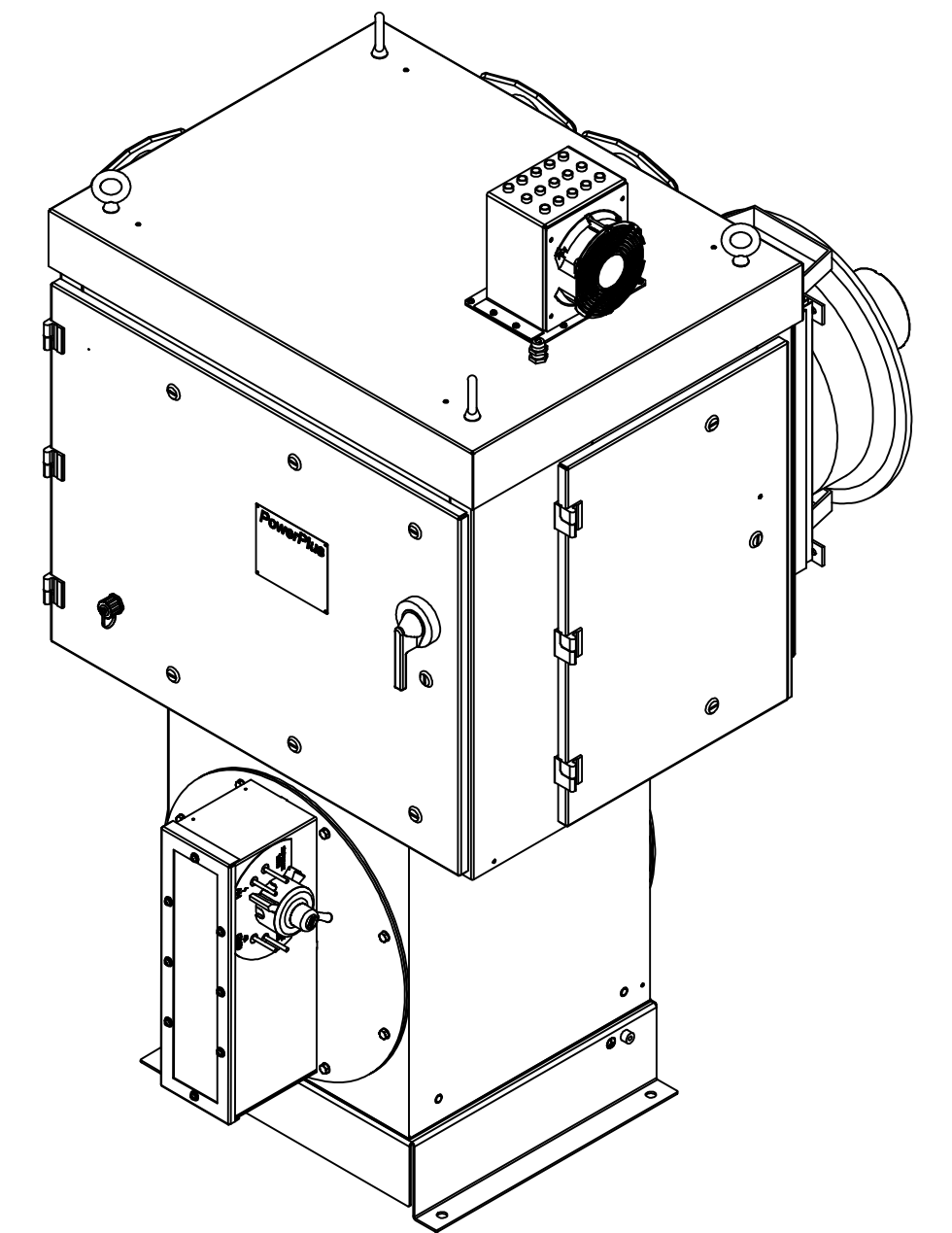

LEFT SIDE

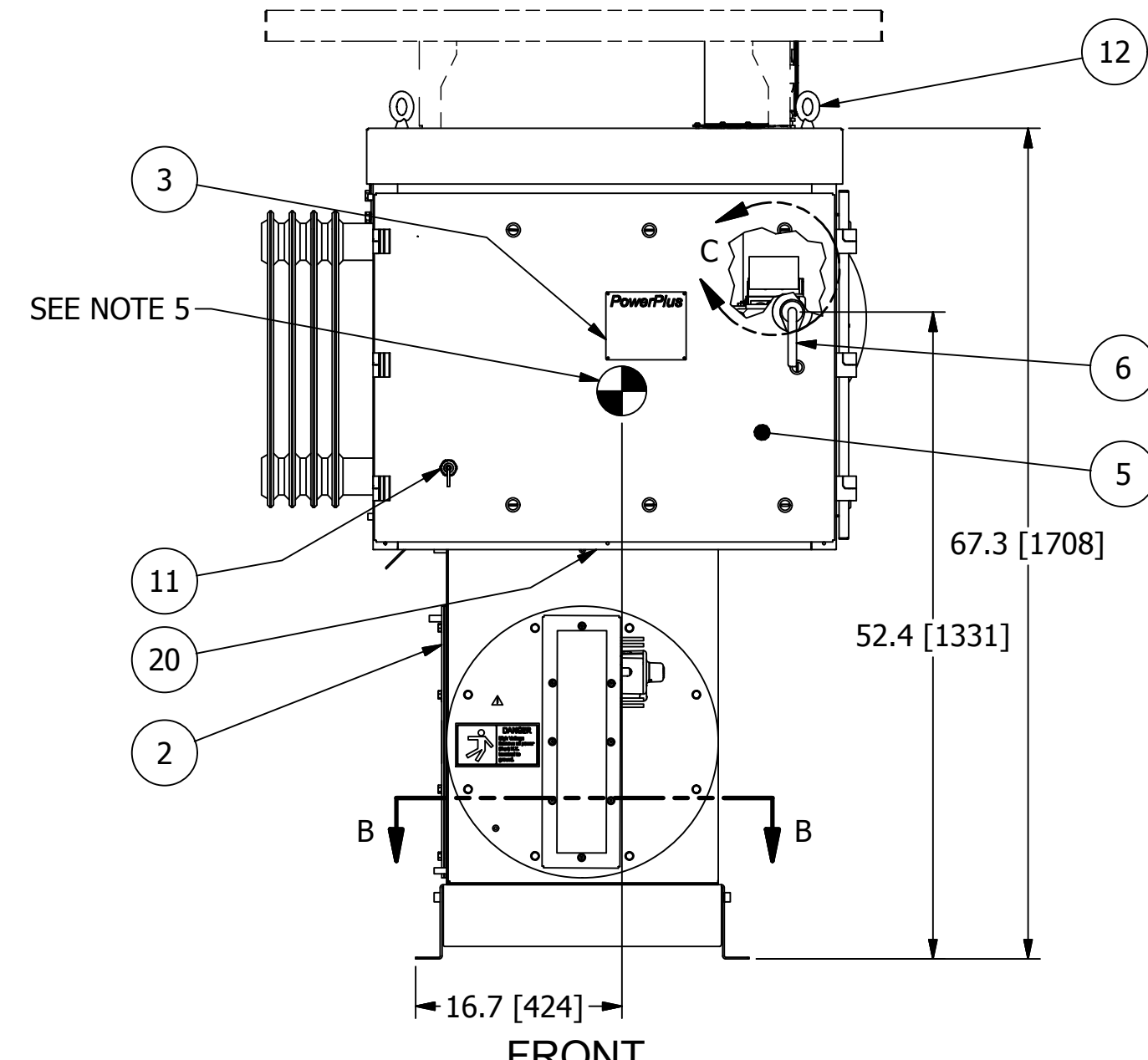

FRONT

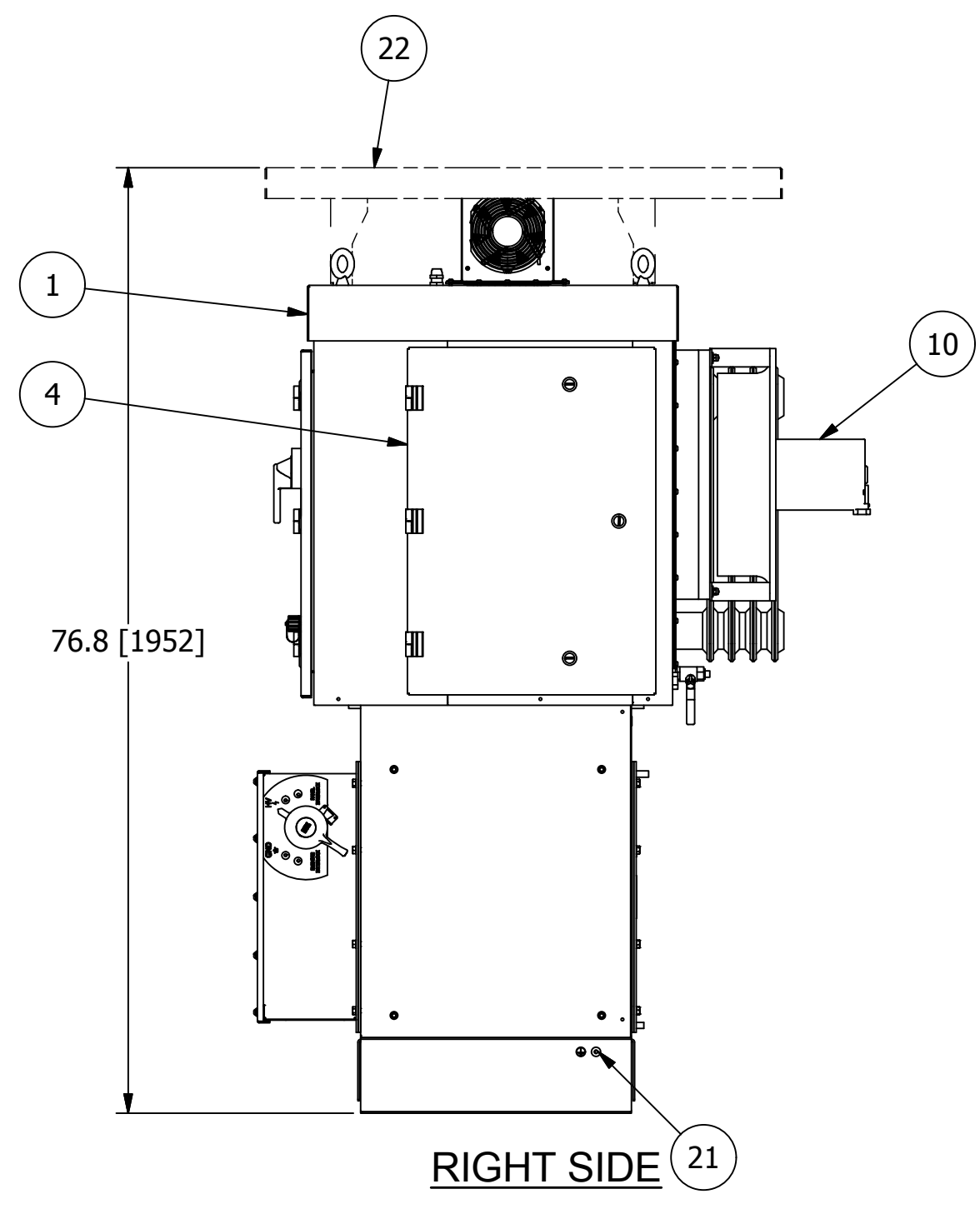

RIGHT SIDE

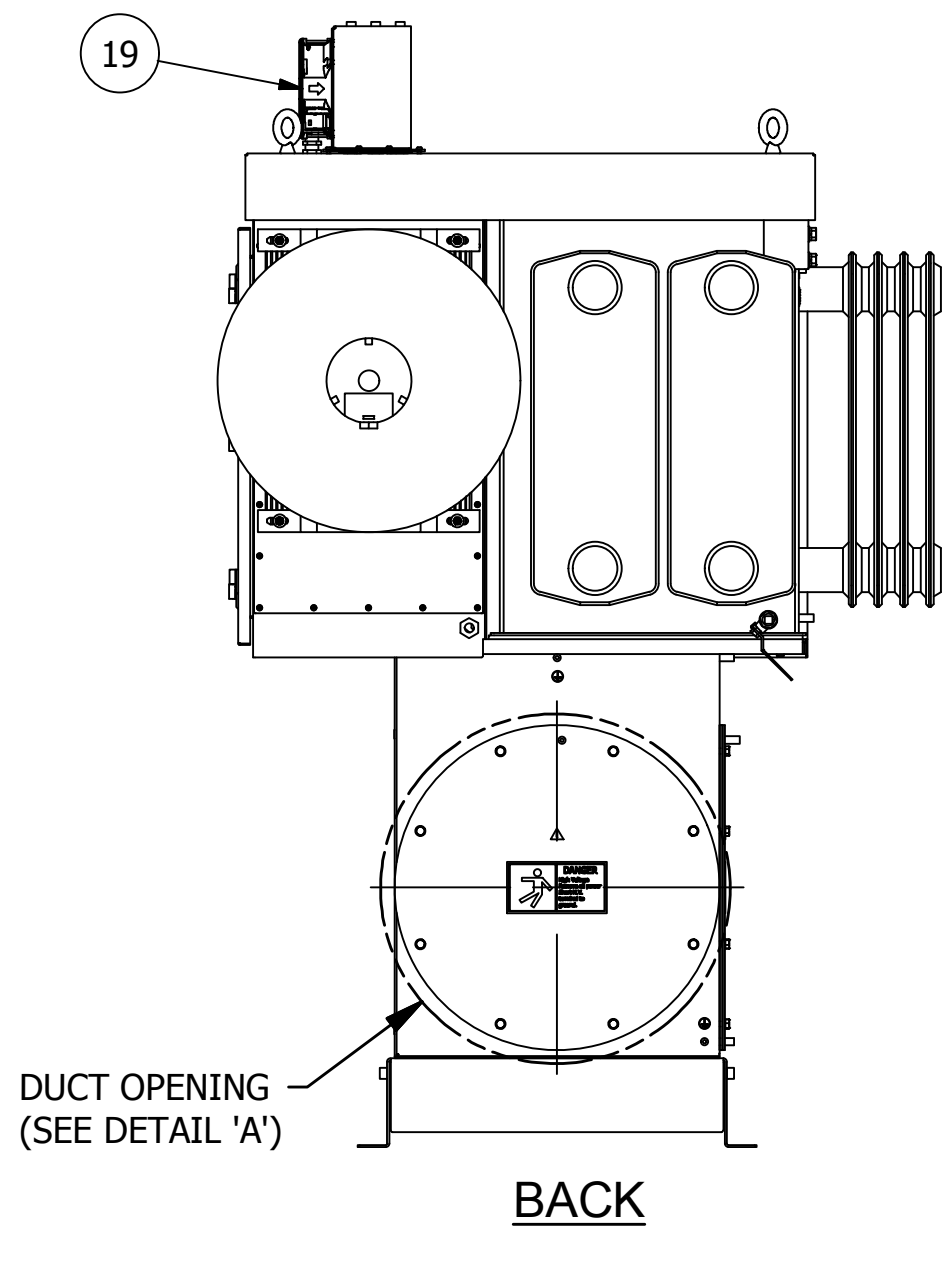

BACK

**BALLOONED NUMBERS:**

- ① POWERPLUS UNIT.
- ② 3 PORT SIDE EXT GROUND SWITCH. SEE ESP-SQ-CONF FOR SWITCH CONFIGURATION OPTIONS.
- ③ RATINGS NAMEPLATE, ALUMINUM PHOTO ETCHED.
- ④ ACCESS DOOR TO POWER ELECTRONICS SECTION. ALLOW 19" [483] OF CLEARANCE FROM THIS FACE FOR DOOR SWING.
- ⑤ ACCESS DOOR TO SWITCHGEAR AND CONTROL SECTION. ALLOW 37" [940] OF CLEARANCE FROM THIS FACE FOR DOOR SWING.
- ⑥ INPUT CIRCUIT BREAKER SWITCH HANDLE W/ INTERLOCK PROVISION INSIDE. SEE DWG C140616.
- ⑦ 1" [25.4] DIA. CONDUIT HOLE FOR 120V CONTROL WIRING.
- ⑧ 1/2" [12.7] DIA. CONDUIT HOLE FOR LOW VOLTAGE TRANSDUCER AND COMMUNICATION LINK CONDUIT.
- ⑨ 2" [51] DIA. CONDUIT HOLE FOR 3 PHASE POWER AND GROUND.
- ⑩ COOLING FAN FOR IGBT HEATSINK ASSEMBLY.
- ⑪ WEATHER TIGHT, RJ45 CONNECTOR FOR NWL HMI CONNECTION.
- ⑫ LIFTING EYES (4 PLACES).
- ⑬ H.V. SWITCH MECHANISM W/ VIEWING WINDOW AND INTERLOCK PROVISIONS. SEE DWG A105811.
- ⑭ SIDE EXIT 18" DUCT MOUNTING PROVISION. INCLUDES GASKETS AND 3/8-16 HARDWARE, (8) PLACES ON A 20" [508] DIA. WITH 18" [457] DIA. DUCT OPENING.
- ⑮ SIDE EXIT 22" ACCESS COVER. INCLUDES GASKETS AND 3/8-16 HARDWARE, (8) PLACES ON A 20" [508] DIA. WITH 18" [457] DIA. DUCT OPENING.
- ⑯ HIGH VOLTAGE SEMI-OUTDOOR BUSHING, SEE DETAIL 'A'.
- ⑰ OPTIONAL METRIC ADAPTER FOR H.V. BUSHING CONNECTION. CONVERTS 1/2" NPT TO M20-1.5. SEE DWG A117570.
- ⑱ 0.69" [17.5] HOLE BOLT PATTERN PROVIDED FOR SWITCH BOX MOUNTING. 25.00" [635] X 19.00" [482] BOLT PATTERN.
- ⑲ HEAT EXCHANGER ASSEMBLY.
- ⑳ S.S. GROUND CABLE TO GROUND EACH SECTION, INCLUDING ACCESS COVERS.
- ㉑ EQUIPMENT SAFETY GROUND TERMINATION, 3/8-16 GROUND BOSS.
- ㉒ OPTIONAL SUN SHIELD MUST BE SHIPPED SEPARATELY AND INSTALLED IN THE FIELD.

**SHIPPING NOTES:**

- POWERPLUS WILL BE SHIPPED WITH SQUARE GROUND SWITCH.
- POWERPLUS AND SQUARE GROUND SWITCH COMBINED SHIPPING WEIGHT: 1225lbs [556kg]
- DIELECTRIC FLUID VOLUME: 29gal [110L]
- FINISH: ENAMEL, ASA 61, APPROX. RAL 7042.
- INDICATES CENTER OF GRAVITY.

**INSTALLATION NOTES:**

- POWERPLUS MUST BE MOUNTED ON LEVEL SURFACE OR SHIMMED TO WITHIN 1/8" [3.2] RISE PER 12" [305] RUN.
- MAXIMUM FLOOR LOADING: 305lbs/sq.ft [1489kgs/sq.m]
- COLD ROOF MAY NEED TO BE REINFORCED TO ACCEPT THE WEIGHT OF THE POWERPLUS UNIT.
- MAXIMUM ALLOWABLE DUCT INTERNAL TEMPERATURE: 122°F (50°C). MAXIMUM ALLOWABLE DUCT INTERNAL PRESSURE: 1 PSI (2.04" Hg). THE INSTALLER MUST USE AN ENTRANCE BUSHING IN ROOF TO MEET THESE SPECIFICATIONS.
- POWERPLUS MUST BE GROUNDED TO THE COLD ROOF BY THE END USER. REFER TO DWG B126972 FOR GROUNDING DETAILS.
- ALLOW 120" MINIMUM CLEARANCE ABOVE THE FLOOR TO LIFT AND REMOVE THE T/R RIG ASSEMBLY FROM THE OIL TANK. CLEARANCE DOES NOT INCLUDE RIGGING HEIGHT.
- POWERPLUS AND SWITCH ARE SEALED, RATED NEMA 4/IP56.

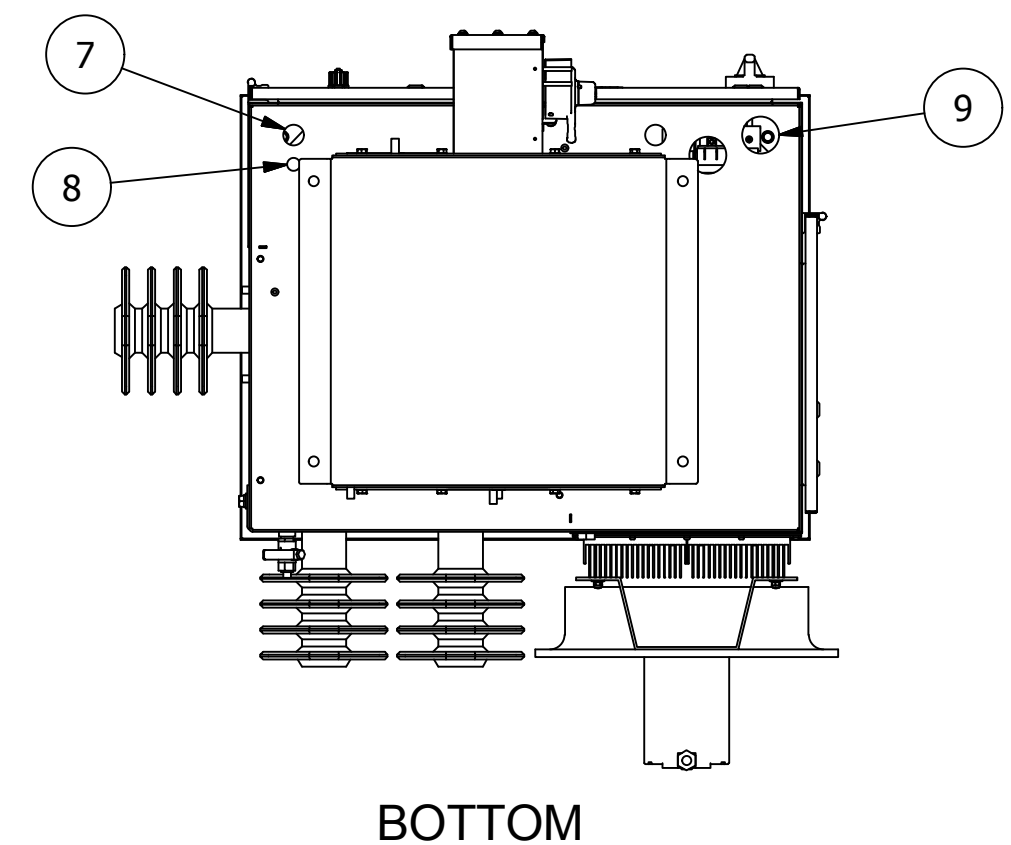

BOTTOM

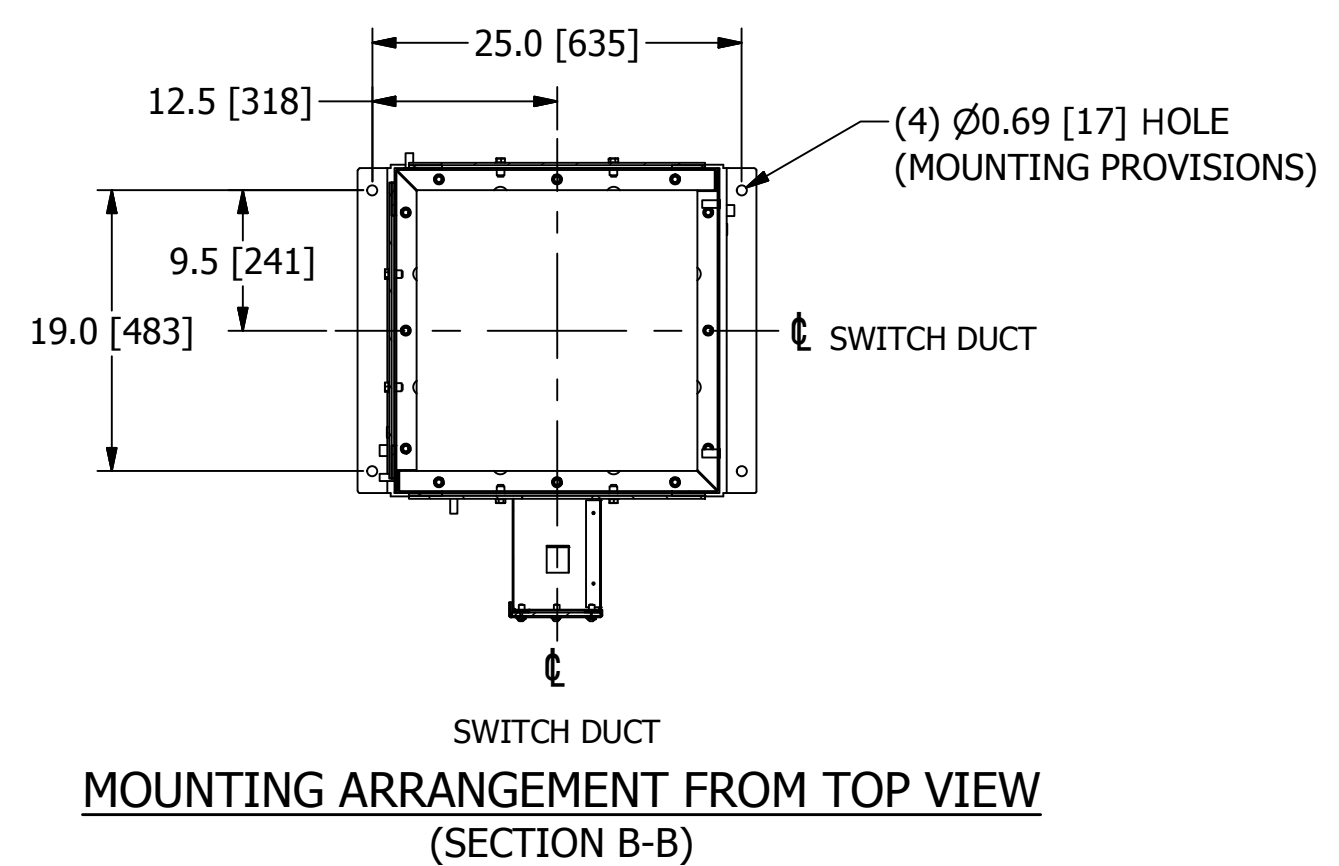

MOUNTING ARRANGEMENT FROM TOP VIEW  
(SECTION B-B)

ALL DIMENSIONS IN INCHES [mm]

<b>NWL</b> 312 RISING SUN RD BORDENTOWN, NJ 08505 TEL. (609) 298-7300 FAX. (609) 298-1982		
TITLE: HF ESP, POWERPLUS SERIES 7.5, 45-70KW UNITS, w/ SQUARE GROUND SWITCH		
SCALE: N/A	APP'D BY: RJK	REVISION DATE: 2/15/19
DWG BY: SDE	D.E. RJK	DWG: 45-70SQ_S7.5
TOLERANCES: (UNLESS OTHERWISE SPECIFIED) ANGLES: +0.5 DEG DECIMALS: .XX +0.005 FRACTIONS: +0.3/16		NWL PROPRIETARY INFORMATION. NOT TO BE REPRODUCED WITHOUT WRITTEN CONSENT

8 7 6 5 4 3 2 1