

8 7 6 5 4 3 2 1

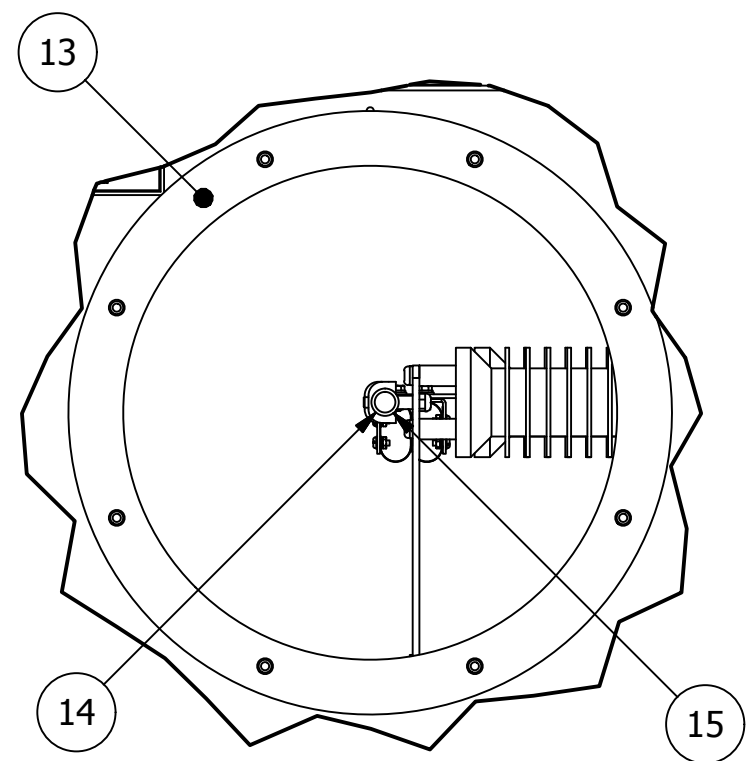

DETAIL A
SCALE 1 / 7

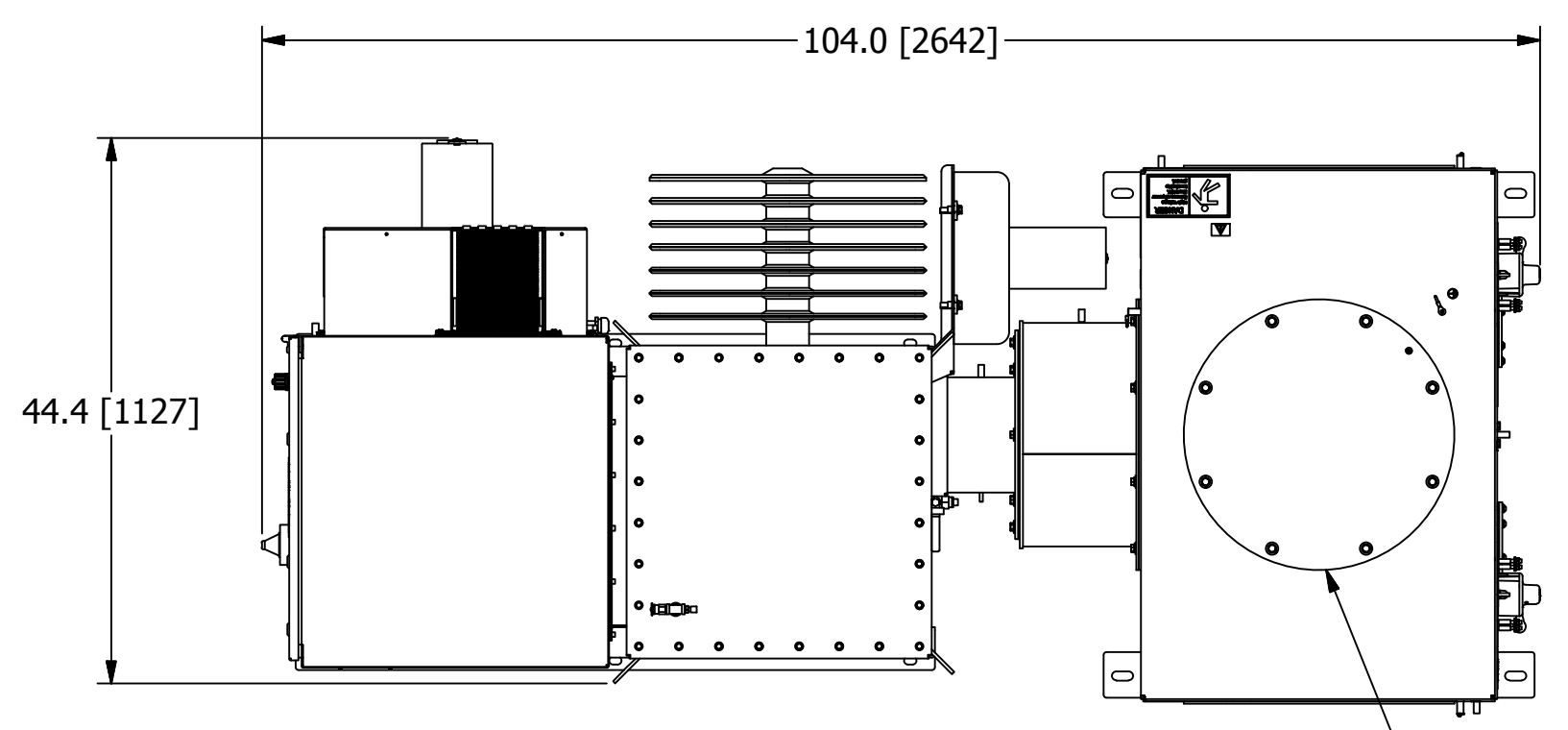

TOP VIEW

3 PHASE CIRCUIT BREAKER PER DWG ESPELECT-06
TABS TO ACCEPT 3/8" LUGS, TORQUE TO 80in-lbs.

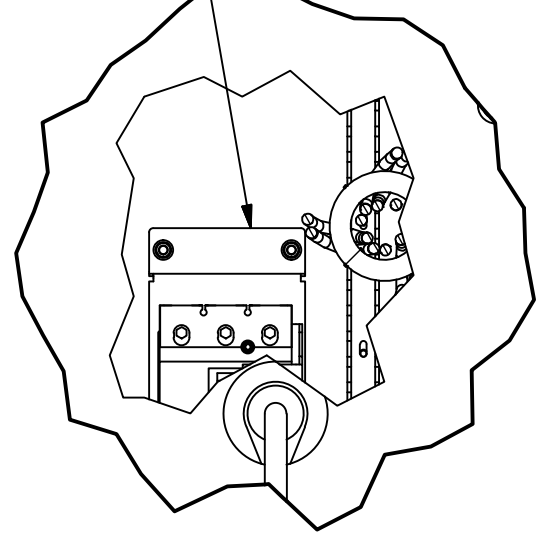

DETAIL C
CIRCUIT BREAKER DETAIL
SCALE 1 / 6

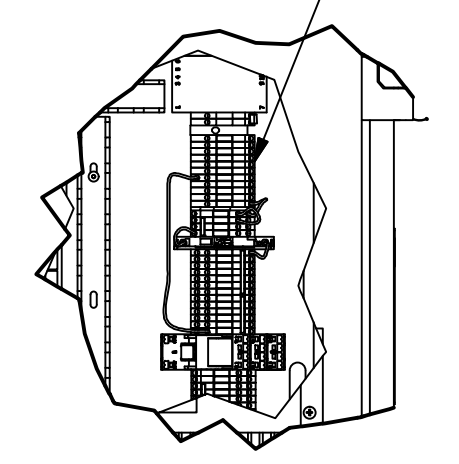

DETAIL D
TERMINAL BLOCK RAIL ASSEMBLY
SCALE 1 / 6

FOR DETAILS REFER TO
DWG ESPELECT-06

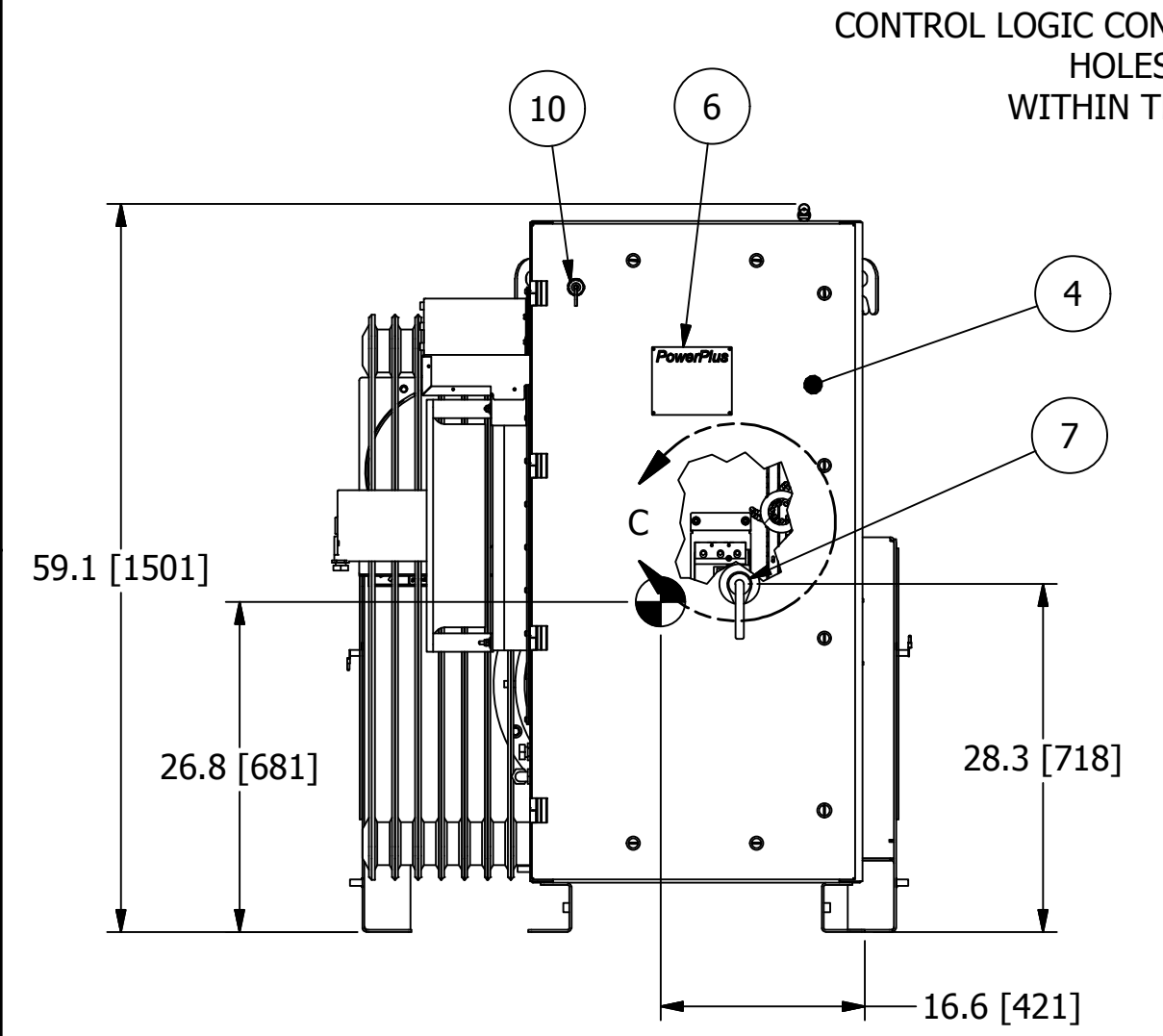
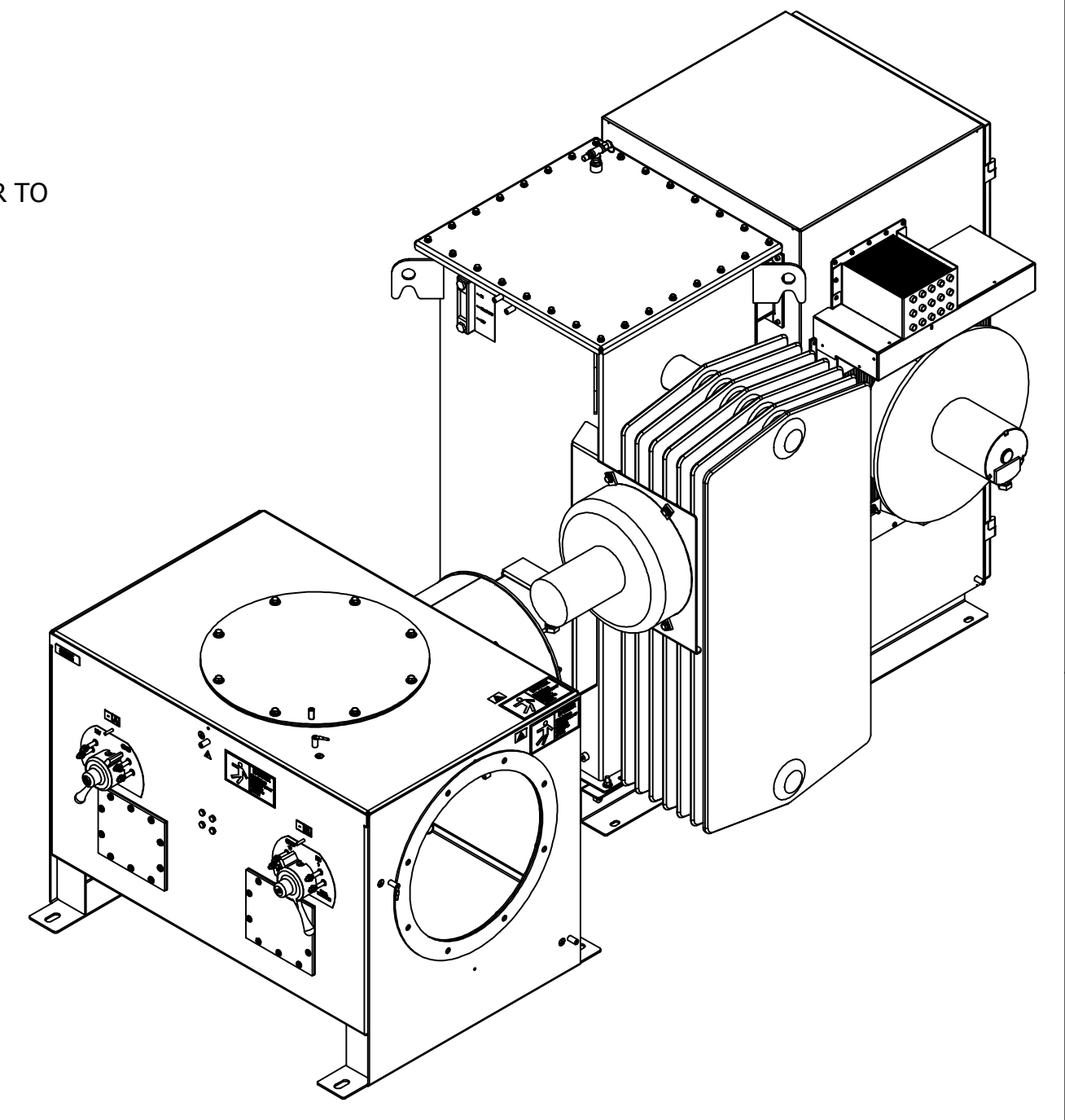

FRONT VIEW

CONTROL LOGIC CONDUIT HOLE LOCATION
HOLES MUST BE CONTAINED
WITHIN THE RECTANGULAR BOX

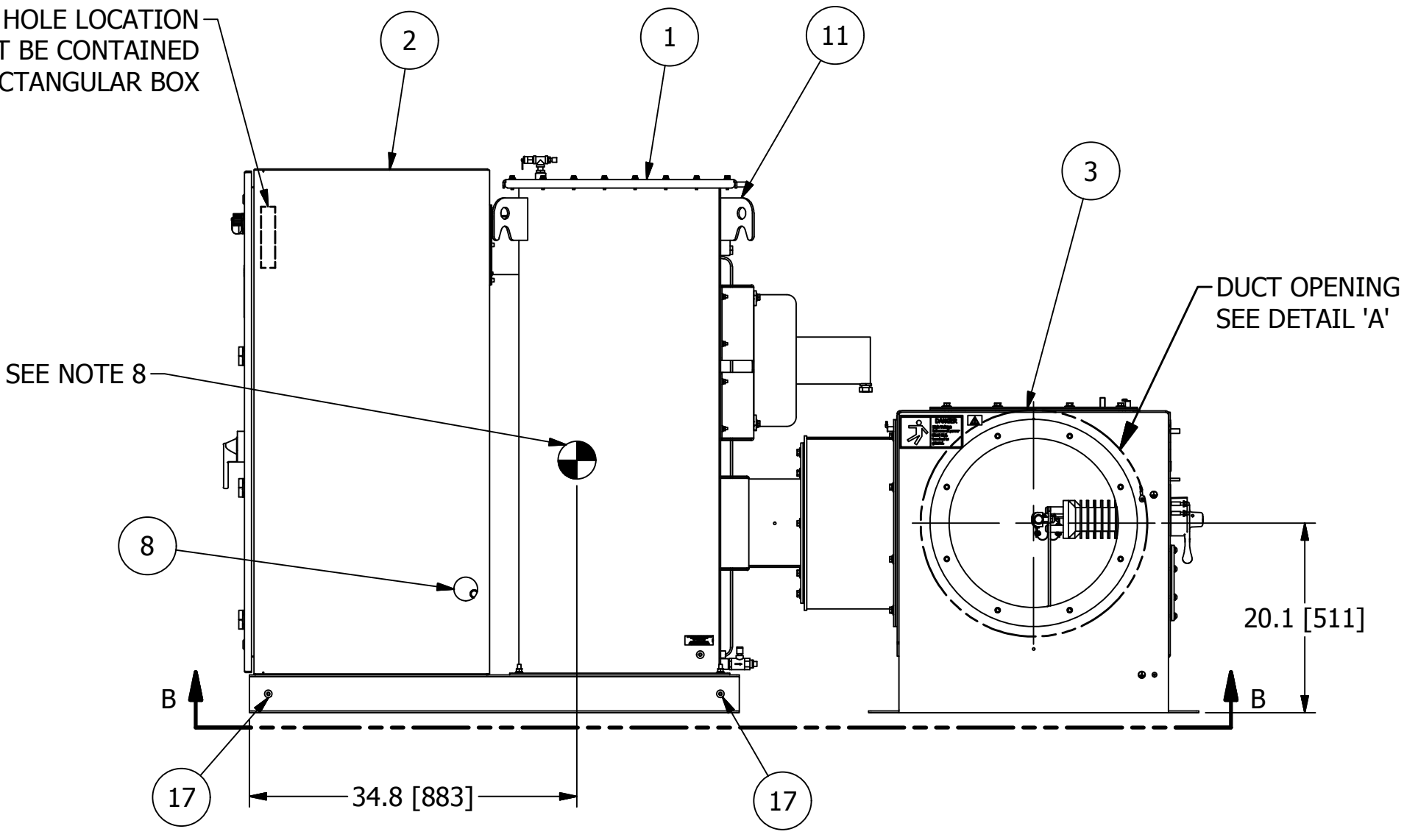

RIGHT VIEW

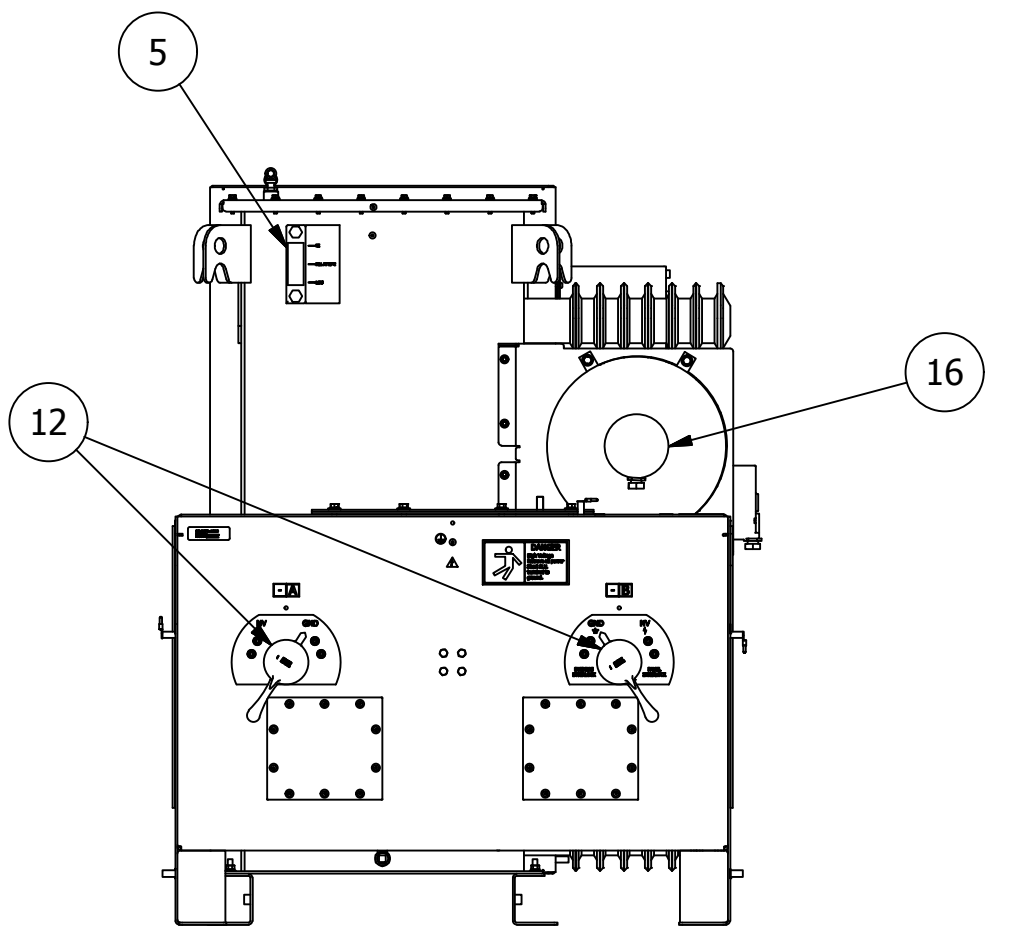

REAR VIEW

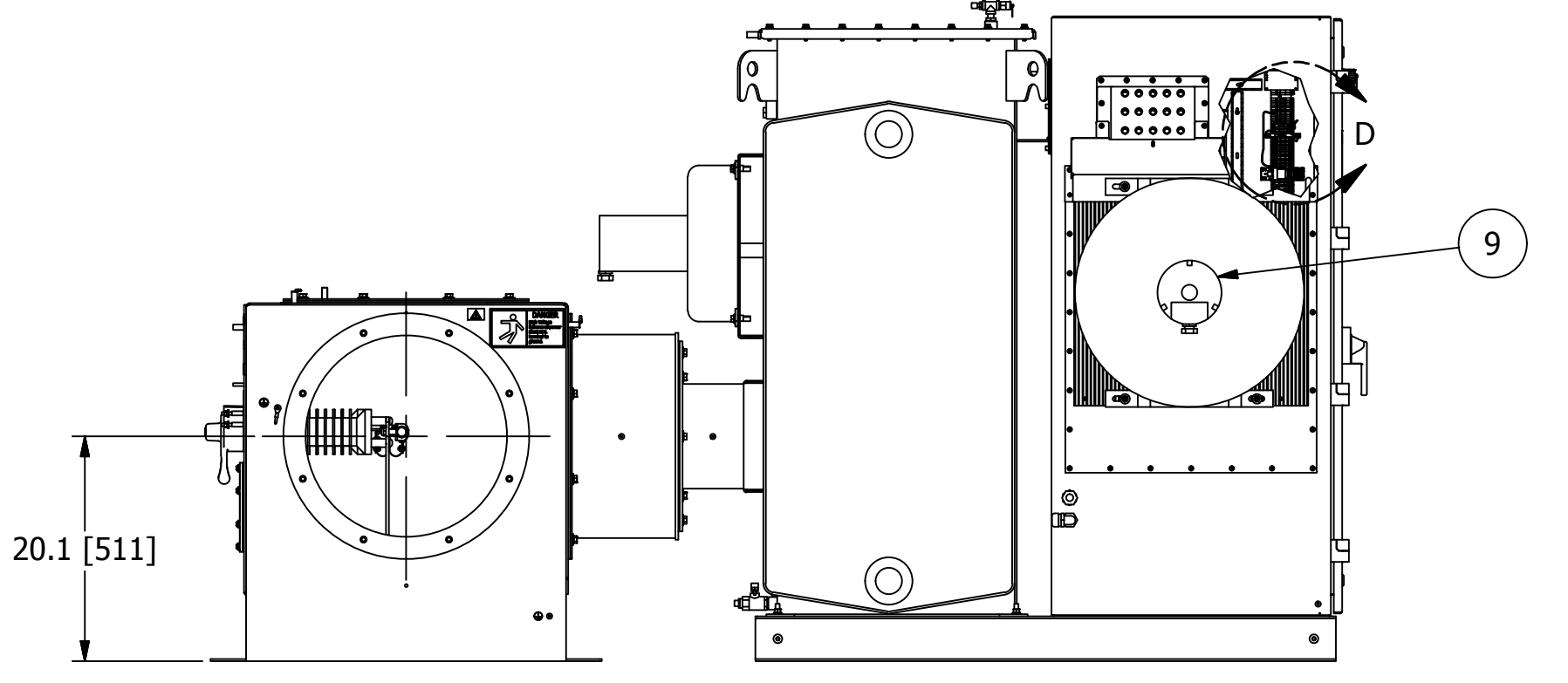

LEFT VIEW

- SHIPPING NOTES:**
1. POWERPLUS WILL BE SHIPPED SEPARATELY.
 2. SPLITTER SWITCH MUST BE SHIPPED SEPARATELY AND INSTALLED IN THE FIELD.
 3. SPLITTER SWITCH WILL BE SHIPPED WITH GASKET AND MOUNTING HARDWARE.
 4. POWERPLUS SHIPPED WEIGHT: 2220lbs [1007kg]
 5. SPLITTER SWITCH SHIPPING WEIGHT: 375lbs [170kg]
 6. DIELECTRIC FLUID VOLUME: 100gal [379L]
 7. FINISH: ENAMEL, ASA 61, APPROX. RAL 7042.
 8. INDICATES CENTER OF GRAVITY.

- INSTALLATION NOTES:**
1. POWERPLUS MUST BE MOUNTED ON LEVEL SURFACE OR SHIMMED TO WITHIN 1/8" [3.2] RISE PER 12" [305] RUN.
 2. MAXIMUM FLOOR LOADING: 305lbs/sq.ft [1489kgs/sq.m]
 3. COLD ROOF MAY NEED TO BE REINFORCED TO ACCEPT THE WEIGHT OF THE POWERPLUS UNIT.
 4. MAXIMUM ALLOWABLE DUCT INTERNAL TEMPERATURE: 122°F (50°C). MAXIMUM ALLOWABLE DUCT INTERNAL PRESSURE: 1 PSI (2.04" Hg). THE INSTALLER MUST USE AN ENTRANCE BUSHING IN ROOF TO MEET THESE SPECIFICATIONS.
 5. POWERPLUS MUST BE GROUNDED TO THE COLD ROOF BY THE END USER. REFER TO DWG B126972 FOR GROUNDING DETAILS.
 6. ALLOW 120" MINIMUM CLEARANCE ABOVE THE FLOOR TO LIFT AND REMOVE THE T/R RIG ASSEMBLY FROM THE OIL TANK. CLEARANCE DOES NOT INCLUDE RIGGING HEIGHT.
 7. POWERPLUS AND SWITCH ARE SEALED, RATED NEMA 4/IP56.

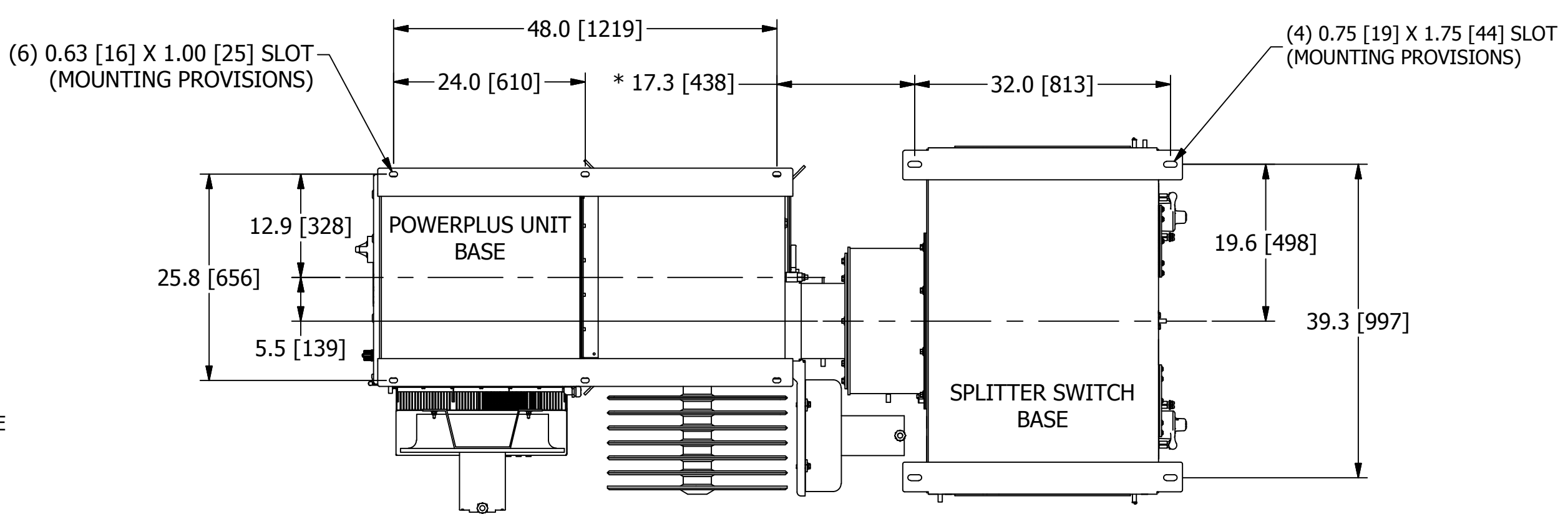

MOUNTING ARRANGEMENT FROM BOTTOM VIEW
(SECTION B-B)

* FOR REFERENCE ONLY. POWERPLUS
ASSEMBLY MUST BE FIELD FITTED TO THE H. V. DUCT WORK
PRIOR TO SECURING TO ROOF.

BALLOONED NUMBERS

- 1 POWERPLUS H.V. TANK.
- 2 POWERPLUS CONTROLLER UNIT.
- 3 SPLITTER SWITCH.
- 4 ACCESS DOOR TO CIRCUIT BREAKER TERMINALS, FUSES AND 3 PHASE RECTIFIERS. ALLOW 37" [940] OF CLEARANCE FROM THIS FACE FOR DOOR SWING.
- 5 LIQUID LEVEL GAUGE AND TEMPERATURE GAUGE FOR OIL TANK
- 6 RATINGS NAMEPLATE, ALUMINUM PHOTO ETCHED.
- 7 INPUT CIRCUIT BREAKER SWITCH HANDLE W/ INTERLOCK PROVISION INSIDE. SEE DWG C140616.
- 8 2-1/2" [63.5] DIA. CONDUIT HOLE FOR AC ENTRY.
- 9 COOLING FAN FOR IGBT HEATSINK ASSEMBLY.
- 10 WEATHER TIGHT, RJ45 CONNECTOR FOR NWL HMI CONNECTION.
- 11 LIFTING HOOKS (4 PLACES).
- 12 H.V. SWITCH MECHANISM W/ VIEWING WINDOW AND INTERLOCK PROVISIONS. SEE DWG A105812.

- 13 SIDE EXIT 18" DUCT MOUNTING PROVISION. INCLUDES GASKETS AND 3/8-16 HARDWARE, (8) PLACES ON A 20" [508] DIA. WITH 18" [457] DIA. DUCT OPENING.
- 14 1/2" NPTF OUTPUT CONNECTION.
- 15 OPTIONAL METRIC ADAPTER FOR H.V. BUSHING CONNECTION. CONVERTS 1/2" NPT TO M20-1.5. SEE DWG A117570.
- 16 RADIATOR COOLING FAN
- 17 EQUIPMENT SAFETY GROUND TERMINATION, 3/8-16 GROUND BOSS.
- 18 SIDE EXIT 22" [559] ACCESS COVER. INCLUDES GASKETS AND 3/8-16 HARDWARE (8) PLACES ON A 20" [508] DIA. B.C. WITH 18" [457] DIA. DUCT OPENING.

ALL DIMENSIONS IN INCHES [mm]

NWL 312 RISING SUN RD BORDENTOWN, NJ 08505 TEL. (609) 298-7300 FAX. (609) 298-1982		
TITLE: HF ESP, POWERPLUS SERIES 7.5, 84-120kW UNITS, w/ SPLITTER SWITCH		
SCALE: N/A	APP'D BY: RJK	REVISION DATE: 2/15/19
DWG BY: SDE	D.E. RJK	DWG: 84-120SP_S7.5
<small> TOLERANCES: (UNLESS OTHERWISE SPECIFIED) ANGLES: +0.5 DEG DECIMALS: .XX +/- 0.05 FRACTIONS: +/-. 3/16 DECIMALS: .XXX +/- 0.005 </small>		

8 7 6 5 4 3 2 1