



DSP Graphic Voltage Controller (GVC)

Retrofit Installation and Startup Guide

Dwg. A131853

Revisions

Rev.	Date	Author	Description
0	9/9/10	FGS	Initial
A	1/4/13	FGS	Changed Recommended mADC Shunt Values for DSP Version
B	12/23/14	FGS	Updated for use with GDU
C	1/7/21	SAB	Updated page 34-35 (Auxiliary Alarm Configuration)
D	6/6/22	SAB	Updated Page 18 and Appendix 3 (Keypad/Display Mounting) for use with GDU p/n G20855A
E	1/25/24	SAB	Updated Appendix 3 with 'to scale' mounting templates
F	3/25/24	SAB	Updated page 10 (Connecting Systems with Solid State Relays to Alarm Inputs)

WARNING! High Voltage!

T/R power supplies contain dangerous and potentially lethal voltages.

- Do not attempt to install the GVC module into a T/R controller while it is operating.
- Turn off power to the T/R set and ground its high-voltage bushing before doing any physical or electrical installation of GVC circuit boards.
- Take precautions against shock or electrocution.
- Ground any electrical storage devices such as capacitors before touching electrical connections.
- Do not stand in water or on damp surfaces while working on a T/R set.
- NWL will not be liable for death, injury, or damages resulting from the unsafe installation or operation of this device.

How to Use This Manual

You are about to install the most advanced voltage controller available for electrostatic power supplies: the NWL Graphic Voltage Controller (GVC).

For all its sophistication, the GVC is easy to use. That's because it utilizes a multi-line graphical screen that displays ESP operating parameters and guides you through any reconfigurations.

It's also simple to install, especially if you're replacing an existing NWL automatic voltage controller.

If you are replacing an NWL automatic voltage controller, such as the MicroPack III™, or a earlier version of the GVC, read **Section I: Before You Start** first. Then turn to **Section III: Installation and Configuration**. You probably do not need to read **Section II: System Requirements and Compatibility**, since your new GVC module will use the same wiring and the same trigger board as the existing NWL controller.

If you are replacing a controller from another supplier, **read all three sections and carefully follow all instructions**. This will help assure a smooth installation and fast startup.

If you are familiar with simple mechanical and electrical installation procedures, you should have little trouble adding the GVC to your ESP power supply. This manual will guide you every step of the way.

You should understand how to use the Global Display Unit (GDU) in order to complete system configuration and checkout. The procedure is pretty much self-evident, but if you find some instructions in this manual confusing, consult the GVC Users Guide for more information.

If you have any questions, contact NWL technical support at 1-800-PICK-NWL. We welcome user suggestions on improving any of our manuals or products.

Written and designed at:

NWL
312 Rising Sun Square
Bordentown, NJ 08505 U.S.A.
1-800-742-5695 • 1-609-298-7300
FAX: 1-609-298-8235

Table of Contents

HOW TO USE THIS MANUAL.....	3
TABLE OF CONTENTS.....	4
BEFORE YOU START.....	5
CHAPTER 1: BASIC PROCEDURES.....	6
<i>Follow Safety Precautions.....</i>	6
<i>Guard Against Noise and Spikes.....</i>	6
<i>Tools Required.....</i>	7
<i>Feedback Cabling.....</i>	7
<i>Upgrading Procedures.....</i>	7
SYSTEM REQUIREMENTS AND COMPATIBILITY.....	9
CHAPTER 2: DOES YOUR SYSTEM NEED MODIFICATION?.....	10
<i>Saturable Core Reactor Systems.....</i>	10
<i>Connecting Systems with Solid State Relays to Alarm Inputs.....</i>	10
<i>Alarm Outputs.....</i>	10
<i>Feedback Requirements.....</i>	11
<i>Contactors On/Off Output.....</i>	11
CHAPTER 3: SYSTEM REQUIREMENTS.....	12
<i>Power Input.....</i>	12
<i>Alarm Inputs.....</i>	12
<i>Remote Enable, Remote On Inputs.....</i>	12
<i>Alarm Output.....</i>	13
<i>Contactors On/Off Output.....</i>	13
<i>Feedback Circuits.....</i>	13
<i>SCR Output.....</i>	15
INSTALLATION AND CONFIGURATION.....	16
CHAPTER 4: PHYSICAL INSTALLATION.....	17
<i>Mechanical Installation.....</i>	17
<i>Electrical Connections.....</i>	19
CHAPTER 5: CONFIGURATION.....	23
<i>Preparing for Configuration.....</i>	23
<i>Configuring the System.....</i>	24
CHAPTER 6: SYSTEM ENERGIZATION AND CHECKOUT.....	38
APPENDIX 1 <i>GENERAL WIRING.....</i>	42
APPENDIX 1A <i>OPTIONAL RAPPER CONTROL BOARD WIRING.....</i>	43
APPENDIX 2 <i>CONTROL MODULE LAYOUT.....</i>	44
APPENDIX 3 <i>KEYPAD/DISPLAY MOUNTING.....</i>	45
APPENDIX 4 <i>TRIGGER BOARD MOUNTING.....</i>	48
APPENDIX 5 <i>CONTROL MODULE MOUNTING.....</i>	49
APPENDIX 6 <i>CONNECTION CROSS REFERENCE FOR REPLACING A G20808 WITH A G20808-01.....</i>	50

Section I

BEFORE YOU START

Chapter 1: Basic Procedures

- Follow Safety Procedures
- Guard Against Noise and Spikes
- Tools Required
- Feedback Cabling
- Upgrading Procedures

Chapter 1: Basic Procedures

Safety, Noise/Spike Prevention, Tools, Cabling, Upgrading

Follow Safety Precautions

WARNING! Transformer/rectifier power supplies for electrostatic precipitators (T/R sets) contain dangerous and potentially lethal voltages. For your safety, observe the following precautions:

- De-energize (turn off power to) the T/R set and ground its high voltage bushing before attempting the physical or electrical installation of any GVC circuit boards.
- Take precautions against shock and electrocution.
- Ground any electrical storage devices, such as capacitors, before attempting to work on your T/R set or controller.

Do not stand in water or on damp surfaces while working on the T/R set or controller.

NWL, its parent corporation and affiliates will not be liable for death, injury or damages resulting from the unsafe installation or use of this device.

Guard Against Noise and Spikes

Noise and spikes in your electrical supply can cause malfunctions in electronic control systems. You need "clean" power for proper operation and to prevent damage. We strongly recommend you take the following steps to insure noise- and spike-free power. You will find more specific instructions later in this manual.

Check the electrical ground.

If you're using the GVC as a direct replacement for an older analog voltage controller, the existing ground may not be adequate for reliable operation. We recommend that you use *at least* a #6AWG ground with the control module, *tied directly to the earth ground from the T/R set control cabinet.*

Avoid long wiring runs to the SCRs.

Install trigger board module G70050 as close to the SCRs as possible to keep wiring runs short. This will reduce the chance of picking up noise.

Install surge protection on feedback circuits.

Some sites may have problems with noise spikes generated in the wiring by precipitator sparking. To prevent this, install MOV-based surge arrestors on the secondary feedback circuits. The arrestors should be rated between 25VDC and 120VDC. We recommend that you install them where the feedback wiring terminates in the T/R set control cabinet.

Severe surging, or spiking, calls for stronger measures. Isolation amplifiers or EMI filters will solve most problems. However, they are rarely necessary.

Follow good wiring practice.

Keep the 480VAC power supply lines physically separated from the signal and control lines, so the controller doesn't pick up noise from the high-voltage cables.

Keep spikes off the power lines.

Variable frequency drives connected to the 480VAC power lines can induce transient spikes into those lines and the 120VAC circuits they feed. Large transients that reach the GVC can cause loss of line synchronization or false firing of the SCRs. The remedy: add filtering on either the 480VAC or 120VAC lines to remove the spikes. Contact NWL for additional assistance.

Tools Required

Standard mechanical and electrician's tools are fine for most installations. These include.

- wire cutters/strippers
- screwdrivers, pliers, nut drivers
- electric drill
- hole cutter for T/R set control cabinet (optional)
- volt/ohm meter
- clamp-on current meter

For system checkout we strongly recommend that you use an *external true RMS meter* to calibrate the digital metering on the GVC. This will give you more accurate readings on an SCR-controlled system.

Feedback Cabling

NWL strongly recommends the use of shielded cable on all feedback wiring to the GVC. Shielding prevents induced noise from other equipment or adjacent AC lines from reaching the unit.

Upgrading Procedures

Major modifications to your T/R set are usually not required. All that's necessary is care in making the electrical connections. Even non-NWL T/R sets rarely present a challenge. Where modification is required, the procedures are simple and straightforward.

Upgrading an NWL controller

If you are replacing an NWL voltage controller, such as the Micropack III, or an earlier version of the GVC, you probably do not need to read **Section II: System Requirements and Compatibility**. The correct electrical connections are in place and the feedbacks are already properly scaled. You simply hook them up. You may go directly to **Section III: Installation and Configuration** for instructions.

Upgrading another manufacturer's controller

You must follow the procedures in Section II: System Requirements and Compatibility to assure correct installation. Failure to do so may cause improper operation of the GVC or damage to the unit. Incorrect

installation will void your warranty. NWL will not be responsible for any problems resulting from incorrect installation.

However, you will find the instructions in **Section II** relatively easy to follow. They tell you how to make sure your system is properly configured before actual installation. For the most part you simply identify the feedbacks, scale them properly, and make sure that the power supply is adequate for operation. If you need to make any modifications for correct GVC operation, they are usually minor.

Once you have completed this preparation you can proceed to the actual installation and configuration process.

Note that your GVC requires 120VAC for operation. **See Section II, Chapter 3: System Requirements**, for details on supplying this power if it is not already present.

SYSTEM REQUIREMENTS AND COMPATIBILITY

Chapter 2: Does Your System Need Modification?

- Saturable Core Reactor Systems
- Systems with Solid-State Relay-Based Alarm Inputs
- Alarm Outputs
- Feedback Requirements
- Contactor On/Off Output

Chapter 3: System Requirements

- Power Input
- Alarm Inputs
- Remote Enable, Remote On Inputs
- Alarm Output
- Contactor On/Off Output
- Feedback Circuits
- SCR Output

Chapter 2: Does Your System Need Modification?

Extra Hardware May Be Required

The NWL GVC Retrofit Kit is shipped with all the hardware required for over 90% of T/R controllers. This takes the form of three separate components:

1. GDU module for front-panel or network installation
2. T/R control module, for installation inside the control cabinet. This includes the following circuit boards:
 - I/O board, for connecting feedbacks, alarms, etc.
 - CPU board, containing the microprocessor and control circuitry
 - Power supply
 - Tumbling hammer control daughter board (optional)
3. SCR trigger module, for installation at the SCR

If you are upgrading from an NWL Micropack II, Micropack III, or earlier version GVC, you will not need the SCR trigger module, since one is already in place.

We also supply all cables for interconnecting the three major components.

However, there are a few ESP power supplies that require additional hardware to make them compatible with the GVC. If your system falls under any of the categories below, obtain and install the proper parts before installing the GVC. You'll find more complete information in **Chapter 3: System Requirements**. If you have any questions about these requirements after reading the present chapter and **Chapter 3**, contact NWL technical support.

Saturable Core Reactor Systems

These systems are not compatible with the GVC without modifications to the actual power supply. If the system does not already include SCRs, for example, you will have to add them.

NWL can help you modify saturable core systems for compatibility with the GVC. Contact our technical support staff. In most cases we will need to see the circuit schematic for your saturable core system before we can determine what hardware you will need.

Connecting Systems with Solid State Relays to Alarm Inputs

Alarm inputs must be based on 120VAC dry-contact logic (relays). If your system uses solid state relays for alarm inputs, you must add load-down resistors of 5K Ω or lower, rated 5W or higher.

See **Chapter 3: System Requirements** for more information.

Alarm Outputs

The GVC has a mechanical relay with dry contacts for a common alarm output. The output contacts are rated for 250VAC/30VDC and are fused for 2.5 amps for system protection. If your alarm annunciation circuit requires different voltages, an auxiliary relay for switching the contactor will need to be installed.

Feedback Requirements

Certain feedback circuits have specific hardware requirements, as listed below.

Primary voltage feedback

This must be supplied by a potential transformer of 10VA or more. *Chapter 3: System Requirements* lists acceptable transformer types. If this transformer-supplied feedback is not available in your system, contact NWL technical support for suggested modifications.

Primary current feedback

Primary current feedback should utilize a current transformer (CT) with sufficient capacity to provide 1VA to the GVC in addition to any other circuitry it presently supplies. To meet this requirement you may need to replace the existing CT with a larger one, or add a second CT.

Milliamp DC feedback

All precipitator load current must go through a milliamp feedback resistor to provide approximately 0-10VDC at rated T/R current. Check to make sure this resistor is in place and properly connected.

Contactor On/Off Output

The GVC has a mechanical relay with dry contacts for contactor switching. The output contacts are rated for 250VAC/30VDC and are fused for 2.5 amps for system protection. If the contactor uses a 480VAC coil, an auxiliary relay for switching the contactor will need to be installed.

Chapter 3: System Requirements

Power, Inputs, Outputs, Feedbacks

If you are upgrading to the NWL GVC from another manufacturer's voltage controller, you must check your system for two reasons:

1. To identify the various signal and power lines for later hookup.
2. To make sure your ESP power supply meets all requirements for proper GVC operation.

In this chapter we will walk through specifications for each GVC input, output, feedback connection, and power supply connection. We will also suggest ways in which you can correct areas that don't conform to GVC requirements.

Be sure to label all connections clearly as you check them out. This will make final hookup much easier.

Power Input

The GVC requires 120VAC, 50/60Hz. This should be as free of noise and spikes as possible. Proper grounding of the controller, as described in *Chapter 1: Basic Procedures* above, is essential. If your system has variable frequency drives connected to the 480VAC power lines, it is advisable to install filtering on either those lines or the 120VAC circuits they feed to safeguard against potential transient spikes.

Alarm Inputs

Standard alarm inputs must be based on 120VAC logic with dry contacts (relays). The GVC can be configured to work with normally closed or normally open contacts. Normally closed is the default.

Check to see if your system uses solid state relays for alarm inputs. The alarm inputs may not provide enough load for solid state relay-based alarm inputs to function properly.

If the system uses solid state relays, you may need to add load-down resistors to the circuit(s). Proper load resistors will have a value of 5K Ω or lower and a rating of 5W or higher.

Remote Enable, Remote ON Inputs

The Remote Enable and Remote On inputs are commonly used in conjunction with remote pushbuttons, a Main Fuel Trip, or other sensors to energize or de-energize the T/R set. Both inputs require 120VAC, supplied by dry contacts (relays).

120 VAC must be maintained on the Remote Enable input in order to keep the T/R energized. The loss of the 120 VAC at this input will de-energize the T/R and prohibit it from being energized. Once the Remote Enable input is satisfied, momentary application of 120VAC at the Remote On will energize the T/R set.

Check to see if your system uses solid state relays for Remote Enable and Remote On inputs. The input circuits may not provide enough load for Solid State relay-based systems to function properly.

If your system uses solid state relays, you must add load-down resistors to these circuit(s). Proper load resistors will have a value of 5K Ω or lower and a rating of 5W or higher.

Alarm Output

The GVC has a mechanical relay with dry contacts for a common alarm annunciation. The output contacts are rated for 250VAC/30VDC and are fused for 2.5 amps for system protection. If your alarm annunciation circuit requires different voltages, an auxiliary relay for switching the contactor will need to be installed.

Contactor ON/OFF Output

The Contactor On-Off Output energizes the coil of the magnetic contactor. It has a mechanical relay with dry contacts for contactor switching. The output contacts are rated for 250VAC/30VDC and are fused for 2.5 amps for system protection.

Check to make sure your controller is not using a 480VAC contactor coil. If it does use a 480VAC coil, install an auxiliary 120VAC relay to switch contactor power. Drive the relay from the Contactor On/Off Output.

Feedback Circuits

Feedback from the T/R set allows the GVC to control power in response to sparking and other precipitator behaviors. Each feedback circuit has different electrical requirements. *It is vital to system performance and safety that you properly identify each feedback signal line and make sure its values are properly scaled to the requirements of the GVC.*

You should identify the following feedback signal lines for connection to the GVC.

Primary Voltage Feedback

Primary voltage feedback is normally used for metering purposes only. (If there are no secondary voltage feedbacks it is used for voltage limit, undervoltage trip, and overvoltage trip). The primary voltage feedback input will accept 0-150VAC. The required voltage must be supplied by a transformer rated at 10VA or higher.

If your system does not include such a transformer, you must install one. The transformer should be a potential type transformer. We recommend a 4:1 transformer with a 0-150VAC secondary, since 4:1 is the default value for the GVC. Other ratios are usable, but will require reconfiguration of the default parameters.

Do not install a control transformer in a metering circuit. This will yield misleading readings.

Depending on your line voltage you may have to select a different transformer ratio. The proper values are shown in the chart below.

<i>Nominal AC Line Voltage</i>	<i>Potential Transformer Ratio</i>
575V	4:1
480V (default)	4:1 (default)
380V	4:1
240V	2:1
120V	1:1

If a 10VA transformers not available, call NWL technical support to tell us what VA value you have. We may be able to suggest a workable modification.

Primary Current Feedback

Primary current feedback provides the GVC to limit the maximum current supplied to the T/R set. It accepts values of 0-5 amps AC. This input signal is provided by a current transformer (CT) in line with the T/R primary.

The CT must have sufficient capacity to supply all components on the loop, including meters, overload relays, current sensors, long wiring runs, etc, and still deliver IVA to the GVC. The following chart shows suggested CT values for a given T/R rating. If you are unsure of your T/R rating, the primary current panel meters on the T/R set enclosure provide a rough guide.

<i>Panel Meter (Full Scale)</i>	<i>Possible T/R Amps AC Rating</i>	<i>Suggested CT</i>	<i>Number of Loops on CT</i>
25	0-21	50:5	2
50	22-41	50:5	1
75	42-62	150:5	2
100	63-83	100:5	1
150	84-125	150:5	1
200	126-166	200:5	1
250	167-208	500:5	2
300	209-250	300:5	1
400	251-333	400:5	1
500	334-416	500:5	1

Milliamp DC (mADC) Feedback

Your system must include a milliamp feedback resistor to provide input to the GVC control circuit.

This resistor may already be in place in your system. To make sure it is properly sized, check to see if it meets these conditions:

- all precipitator load current must pass through the resistor
- it must be connected between ground and the low side of the rectifier bridge
- the peak of the feedback waveform at the controller input, when viewed with an oscilloscope, must not exceed 15 V_{peak} at the T/R set rated milliamp output.

Typical resistor values for a given T/R rating are shown in the chart below.

<i>Typical mADC Rating</i>	<i>Suggested Sense Resistance</i>	<i>Suggest Resistor Wattage</i>
250	30 Ω	50 watts
500	15 Ω	50 watts
1000	7.5 Ω	50 watts
1500	5 Ω	50 watts
2000	4 Ω	100 watts

These values may vary depending upon the operating conduction angle, the current form factor, load characteristics, and other factors that may change the peak/average ratio of the mA waveform.

Contact NWL technical support for other T/R values.

Kilovolt DC (Secondary Voltage) Feedback

Review the configuration of the T/R set and determine whether it provides a KV metering circuit.

- If the T/R is a full-wave unit (single bushing), you will connect the KVDC feedback circuit to the KV1 input
- If it is a double half-wave unit (dual bushings), you will connect to *both* KV1 and KV2 inputs
- On a T/R set that does not provide a KV metering circuit, do not connect anything to this feedback circuit. The GVC will display a calculated KV reading.

KVDC feedback requires a maximum of 8.4 VDC at the T/R set's rated kVDC. As part of the process covered in *Chapter 5: Configuration* below, you will calibrate the GVC for this range by entering the value of the voltage divider resistor in your T/R set.

To make this calibration accurate and prepare the GVC for voltage sensing, determine the value of the voltage divider resistor in the T/R set.

- If that value is between 40 megohm and 120 megohm, connect a 10 K Ω resistor in series between the voltage divider and ground. Typically this should be a wirewound device with a 12W rating.
- If the value is outside that range, contact NWL for the proper resistor rating.

The 10 K Ω resistor is used for voltage sensing in the feedback circuit.

SCR Output

The SCR output *is* connected to the NWL-supplied trigger board that supplies the necessary isolated gate pulses for the SCRs.

Be sure that the connections at the SCR are properly phased with the 120VAC connections feeding the controller power supply. If they are out of phase, the T/R set will not operate during final system check out. You will then have to reverse the phasing to correct the problem. (See "Chapter 4: Electrical Connections" for a fuller explanation.)

Section III

INSTALLATION AND CONFIGURATION

Chapter 4: Physical Installation

- Mechanical Installation
- Electrical Connections

Chapter 5: Configuration

- Preparing for Configuration
- Configuring the System
- Configuring the Alarms

Chapter 6: Energization and Checkout

- Checking Power Control
- Final Calibration
- Starting Automatic Control

Appendices

Chapter 4: Physical Installation

Mechanical Installation, Electrical Hookup

This chapter covers the physical upgrading of your T/R control enclosure through the installation and wiring of the GVC. Assuming that all relevant wiring in the control cabinet has been identified and tagged, you should be able to complete these two steps in very little time.

Mechanical Installation

Mechanical installation involves mounting the GVC's three component pieces in appropriate locations. The components include:

1. The control module, a single unit consisting of
 - power supply
 - I/O circuit board
 - microprocessor board
 - optional tumbling hammer daughter board
2. The trigger board - if required. (Upgrades from a Micropack II, III, or earlier version of the GVC will continue to use the trigger boards already in place)
3. The Global Display Unit (GDU).

Trigger Board Installation

The trigger board should be mounted as close as possible to the SCRs to minimize noise pickup by the control wires. You can mount it to the SCR assembly.

For easy installation follow this procedure:

1. Refer to the supplied template in the appendices to this manual. Mark the places where you will drill four (4) holes on your chosen mounting location for the unit's plastic standoffs. Make sure that the trigger board will not touch any metal surfaces when mounted on these standoffs.
2. Drill the holes.
3. Secure the plastic standoffs in these holes.
4. Secure the trigger board to the standoffs.

Check again to be sure the trigger board is safely away from all metal surfaces.

Control Module Installation

The control module is already mounted on its own metal plate. Note the four pre-drilled mounting holes in the plate.

First, locate a good place for the module. During electrical installation you will need access to the control module to hook up power, signal, and control lines.

We recommend the back of the control cabinet door, the inside control cabinet wall, or the control cabinet's inside back panel. We also recommend vertical mounting, with the terminal connectors at the top, to conserve

space and reduce dust accumulation by circuit components. Care should be taken not to mount the control module too close (less than 4 inches) to any high voltage (400 VAC or greater) wires or components. These items may generate electric fields that adversely effect the operation of the control module.

1. For easy installation follow this procedure:
2. Refer to the supplied template in the appendices to this manual. Mark the places where you will drill four (4) holes for the unit's mounting hardware.
3. Drill the holes.
4. Mount the plate flush to the control cabinet surface using bolts or studs.

Global Display Unit (GDU) installation

The GDU is a stand-alone processor unit that operates the Windows CE operating system. It also incorporates a rugged 7" color TFT LCD and resistive touchscreen. There are two USB ports, two RS-485 serial ports (RJ45 connector), and an Ethernet port on the back of the unit. Below is a drawing of the back of the unit with all of the components and connections identified.

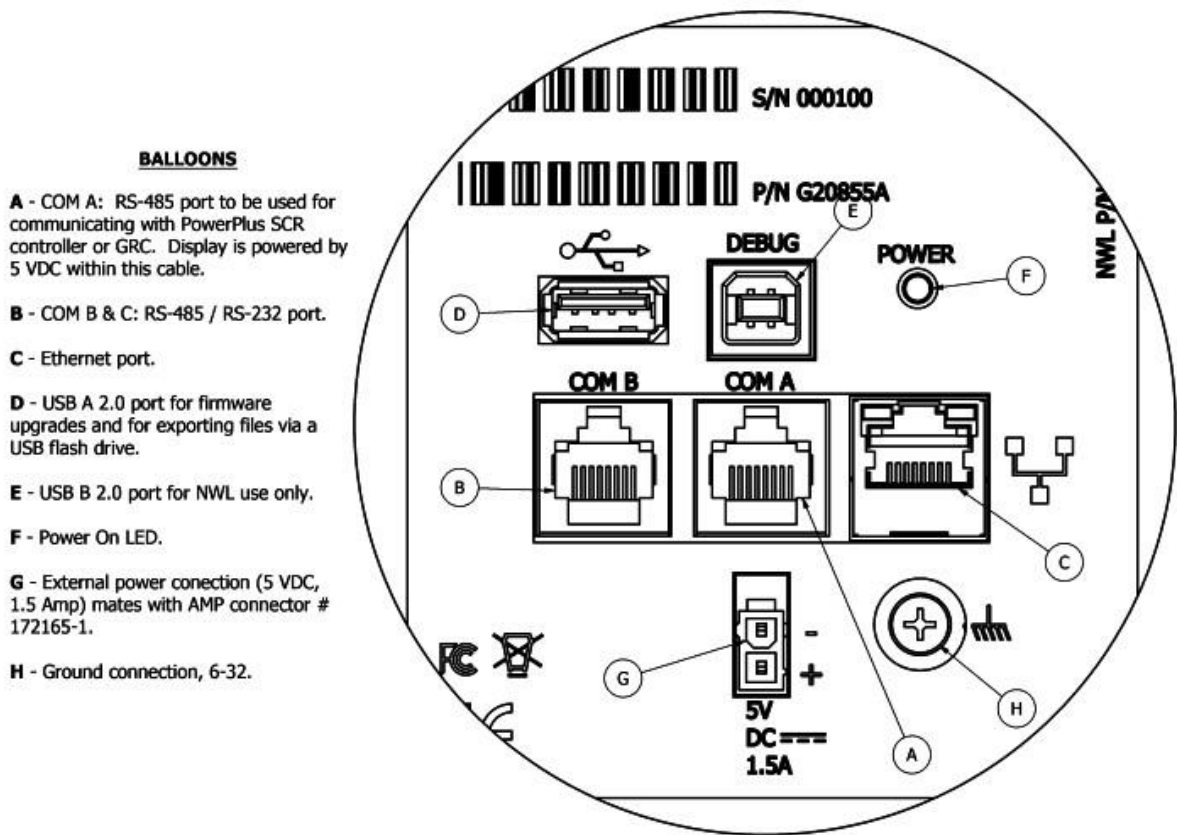

A. If you're permanently mounting the GDU on the control cabinet.

One possible mounting location for the display/keypad is on the T/R controller cabinet door.

1. You can use a standard 4-1/2-inch meter hole if one exists. There are four 6-32UNC threaded mounting holes on the GDU Model # G20855-HH enclosure backplate that will be for attaching the display to the door using the existing meter stud mounting holes.
 - If you do not have an open meter hole, mark positions for screw holes and an opening for the mod jacks using the supplied drawing.
 - Then drill the holes in the cabinet door.
2. Position the display enclosure over the mounting holes in the door.
3. From the inside of the door use lock washers and screws to secure the display to the cabinet.

B. If the display is to be used as a network display.

A single GDU can control up to 90 T/R controllers on a single RS 485 communications link. In this case the network ports on each of the GVC modules must be wired in a multi-drop configuration (also referred to as daisy chained). The GDU can be mounted on one of the control cabinets or remotely in another location within the plant (maximum distance is 4000 ft.). If the GDU is to be mounted remotely it will need to be powered by a separate 5 VDC supply. NWL Model #110045-01 was designed for this specific purpose. It mounts to the back of the GDU internal to the enclosure.

Electrical Connections

All electrical connections between the T/R set and the GVC are made to the control and trigger board modules. Most of these are made to the circuit boards on the control module. These are easy to identify.

As you look at the control module you will see two circuit boards mounted together, one above the other. The bottom one is the I/O circuit board. The top one is the DSP microprocessor circuit board. The power supply stands by itself.

The I/O board, where you'll do all of your wiring, has several connecting points. The ones with which you'll be most concerned are:

- The feedback, alarm/remote input, and alarm/contact output terminal connector labeled J14, J15, & J16 respectively.
- The auxiliary alarm input terminal connector, labeled J17.
- The Mate-N-Lock connector, labeled J3, that provides output to the SCR trigger board.

Refer to the terminal layout drawing and the general retrofit drawing and follow these simple steps to complete your wiring.

Power Supply

1. Run 120VAC to J1 on the control module power supply board, using the supplied cable with the two-pin mate-n-lock connector. If you are upgrading an NWL Micropack III, or an earlier version of the GVC, use the same cable that was plugged into J1 of the previous power supply.

2. Make sure the 120VAC on J1, pin 2 is in phase with the power line voltage on the anode of 1SCR. Refer to the General Retrofit drawing.

I/O Board Connections

1. Connect all power, control, and signal lines to their proper terminal connectors per the table below.

<u>Connector</u>	<u>Circuit</u>
J14-1	Primary Voltage Feedback
J14-2	Primary Current Feedback
J14-3	kVDC (Bushing #1) Feedback
J14-4	kVDC (Bushing #2) Feedback
J14-5	mADC Feedback
J14-6, 7, 8, 9	Feedback Common/Ground
J15-1	AC Overcurrent Alarm Input
J15-2	SCR Overtemperature Alarm Input
J15-3	T/R Overtemperature Alarm Input
J15-4	T/R Low Oil Level Alarm Input
J15-5	Remote Enable Input
J15-6	Remote On Input
J15-7, 8, 9, 10	Alarm Common/Return
J16-1	Remote Alarm Relay Contact – N.C.
J16-2	Remote Alarm Relay Contact – COM.
J16-3	Remote Alarm Relay Contact – N.O.
J16-4	Option Voltage Source Terminal (Internally tied to J16-5)
J16-5	Voltage Source for Contactor Coil (120 VAC typ.)
J16-6	Output to Energize Contactor Coil

2. If you are not using an external overcurrent relay, jumper terminal J15-1 to 120VAC to prevent the GVC from issuing constant false alarms.
3. Wire connector J17 per the table below. This is for the optional user-defined auxiliary alarm dry-contact inputs (contacts rated 20VDC).

<u>Connector</u>	<u>Circuit</u>
J17-1	Aux. Alarm #1
J17-2	Aux. Alarm #2
J17-3	Aux. Alarm #3
J17-4	Aux. Alarm #4
J17-5, 6, 7, 8	Aux. Alarm Common/Return

4. Note connector J7 is used for the optional tumbling hammer daughter board. If you are not using this option, the connector will not be used. If you have ordered the optional rotating hammer board, wire the board terminals per the table below.

<u>Connector</u> <u>(Located on Hammer Bd.)</u>	<u>Circuit</u>
J2-1	Voltage Source for Hammer #1
J2-2	Output for Hammer #1
J2-3	Voltage Source for Hammer #2
J2-4	Output for Hammer #2
J2-5	Voltage Source for Hammer #3
J2-6	Output for Hammer #3

J2-7	Voltage Source for Hammer #4
J2-8	Output for Hammer #4
J1-1	Hammer #1 Aux. Contact Feedback
J1-2	Hammer #2 Aux. Contact Feedback
J1-3	Hammer #3 Aux. Contact Feedback
J1-4	Hammer #4 Aux. Contact Feedback
J1-5, 6, 7, 8	Hammer Feedback Common/Return

- If the GDU is to be permanently mounted on the T/R control cabinet, plug its cable into the desired Local jack, J1, or the Network jack, J2. If the controller is to be part of a RS485 network for communicating to an NWL PCAMS, DCSi, or a network GDU connect the communications wiring to the Network Port connector J9 per the below table.

<u>Connector</u>	<u>Circuit</u>
J9-1	HI (+)
J9-2	LO (-)
J9-3	COM

- If the GDU is to be remotely mounted, but not used as a network display, wire the rs485 communications cable to Local Port connector J8 per the table below.

<u>Connector</u>	<u>Circuit</u>
J8-1	HI (+)
J8-2	LO (-)
J8-3	COM

DSP Board Connections

The only connection on the DSP board is to the optional field bus module, if required. This optional module must be ordered and shipped separately. It is to be installed by the user directly on the DSP board. Refer to the drawing in Appendix 2 for the location of the field bus converter jack.

- Make sure that the mounting feet on the module are fully retracted by turning the two screws on the front plate counterclockwise.
- Carefully line up the module with the mounting rails of the jack. Slowly and carefully start to slide the module into the jack. **As the module approaches the pins in the back of the jack, stop and visually verify that all of the pins in the jack are properly aligned and entering the sockets in the module. If the pins are not properly aligned damage will occur to the jack on the DSP board.** If the pins are all aligned, continue to slowly push the module into the jack until it is fully seated.
- Turn the two screws on the front plate of the module clockwise to secure the module to the DSP board.
- The users wiring will then connect directly to the connector on the field bus module. The type of connection will be dependant upon the specific field bus used.

Trigger Board Wiring

- Plug one end of the supplied 4-wire cable into J3 on the I/O board, and the other end into J1 on the SCR trigger board.
- Connect the trigger board to the SCRs.

3. If you are replacing an NWL controller, use the existing wire from the SCRs. Insert its quick-disconnect plug into J2 on the trigger board.
4. If you are replacing a non-NWL controller, use the supplied pig-tail/quick disconnect cable. Wire the pig-tail end to the SCRs as follows:

<i>Connection Point</i>	<i>Pig-tail gate connection</i>	<i>Pig-tail cathode connection</i>
1 SCR	J2/5	J2/4
2 SCR	J2/2	J2/1

(1 SCR is the one with its cathode on the output side of the SCR assembly.)

5. Then insert the quick-disconnect end of this cable into J2 on the trigger board.

This completes physical installation of the GVC.

Chapter 5: Configuration

Configuring the GVC

You must configure the GVC before using it. Configuration sets up the operating parameters of the T/R set it is controlling, allowing it to

- fully protect the T/R set
- display accurate readings on T/R set operation.

Configuration is necessary when retrofitting an existing T/R set with a new controller. Failure to configure the GVC could result in damage to the T/R set.

This chapter concentrates on configuring the GVC for maximum protection of the T/R. The procedure is short, simple, and straightforward. Most T/R parameters can stay at their preset default values for now.

You will use the display/keypad to set parameters. Basic information on how to use this module is included in the instructions below. Consult the User's Guide if you need more help.

Preparing for Configuration

Prior to energizing the unit, verify that the dip switches located on the DSP board are configured as below.

SW3 – Diagnostics Configuration Switch (For NWL Use Only) – All switch positions should be OFF.

SW4 – Communications Configuration Switch – Switch positions 1 to 3 OFF, Switch position 4 ON.

SW5 – Field Bus Converter Configuration Switch – All switch positions should be OFF.

SW6 – Boot Configuration Switch – All switch positions should be OFF.

To begin the configuration process, make sure the GDU is plugged into the GVC local port on the T/R controller, then follow these procedures.

Power up the T/R controller by moving the power handle on the control cabinet to the "ON" position. **Do not push the <HV On/Off> button on the GDU until configuration is complete!**

1. The display will power up.
2. Sign onto the system, by press the key button  on the bottom section of the screen. The entry window on the screen that appears allows you to enter your access code.

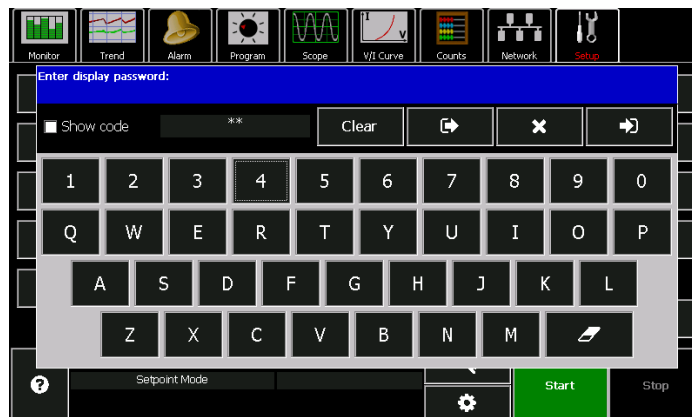

3. Type the password for the desired level of access. The default code for configuring the system is 51.

Press the  button to enter the password. You are now signed on to that level of access.

If in typing your password you make a mistake and need to erase a character, press the  button.

The main menu should now display more options.

Configuring the System

Ratings

Press the **Ratings** button on the **Setup** display on the menu bar. The following screen will be displayed.



This screen shows the electrical ratings for the unit. These ratings must be correct to allow the control to maintain operation within safe values.

V AC: This is the primary voltage rating of the T/R set.

A AC: This is the primary current rating of the T/R set.

kVDC: This is the kVDC rating of the T/R set.

mADC: This is the mADC rating of the T/R set.

Verify that the ratings agree with the T/R nameplate. If they are not correct, press the parameter to be adjusted and then use the +/- 1, 10, or 50 buttons in the bottom left of the screen to change the value by that amount.

The gain adjustments are used to calibrate the meter readings. The

A system calibration should be performed only the T/R and controller are installed and energized. A complete procedure is given in a later section of this manual.

There are two other pages that contain other settings required for the system calibration. Press the number **2** button at the top of the screen.



VAC Turns Ratio: This is the ratio of the primary metering transformer being used to measure the primary voltage at the T/R set. This transformer is usually located in the control enclosure.

AAC Turns Ratio: This is the turns ratio of the current transformer being used to measure the primary current of the T/R set. This CT is usually located in the control enclosure.

Volt Div High Res: This is the value of the high voltage divider resistor being used to measure the KVDC. This resistor is usually located in the T/R tank.

Volt Div Low Res: This is the value of the low voltage KVDC feedback resistor that is in series with the above referenced high voltage divider. It can be located in either the T/R junction box or in the control enclosure.

Press the parameter to be adjusted and then use the +/- 1, 2, or 3 buttons in the bottom left of the screen to change the value by that amount.

When complete press the number 3 button at the top of the screen.

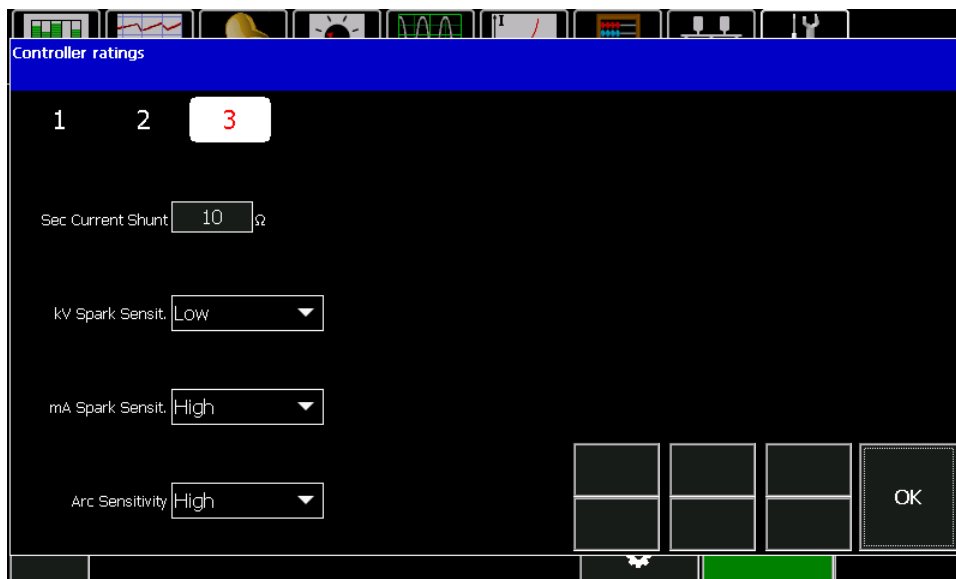



Sec Current Shunt: This is the value of the mADC feedback resistor that is used to measure the T/R output current. It can be located in either the T/R junction box or in the control enclosure.

KV Spark Sensit: This is the spark sensitivity adjustment based on the kVDC feedback. It should initially be set for *High*.

mA Spark Sensit: This is the spark sensitivity adjustment based on the mADC feedback. It should initially be set for *High*.

Arc Sensitivity: This is the arc sensitivity adjustment based on the mADC feedback. It should initially be set for *High*.

Once all of the parameters have been confirmed and/or adjusted press the **OK** button to return to the **Setup** screen.

If the T/R set being controlled is a double-half wave unit, or has no provision for KV feedback, you will have to select the settings that accurately describe the configuration. They can be accessed by pressing the  button next to the On button. Then press the screen option for **Config** and then the page  button.

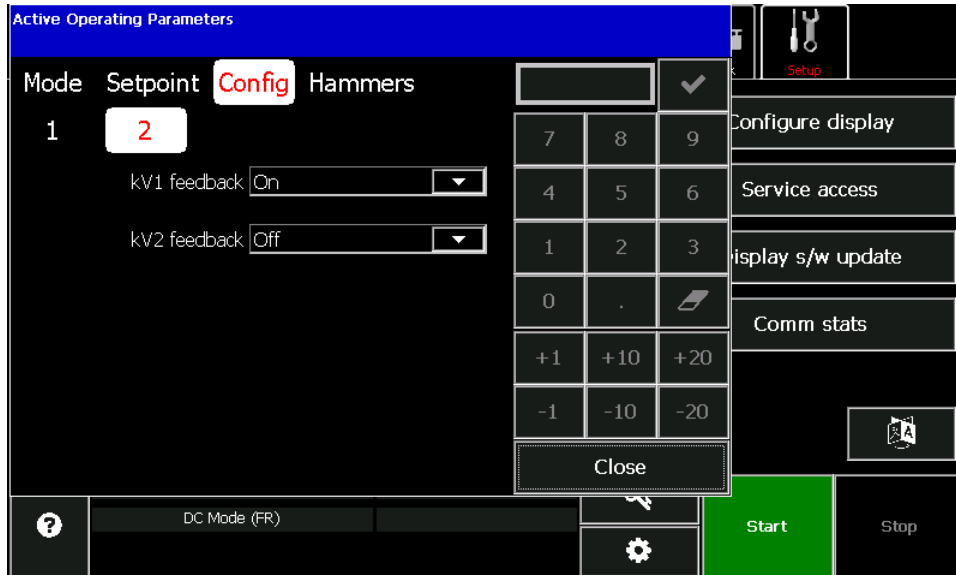

If the T/R does not have provisions for KV feedback, the GVC will calculate the secondary voltage based on the primary voltage reading.

Local Operation

To use the GDU for monitoring and control of a single unit, make sure the display is connected to the local port. Sign On to the system and access Level 3.

Press the **Setup** Button  on the top Menu bar. The following screen will be displayed.

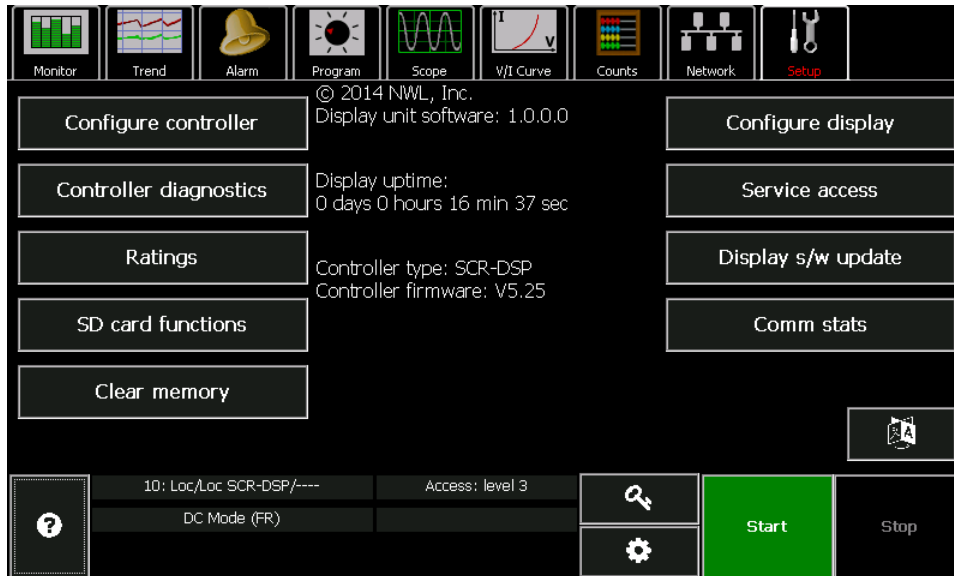

Next press the **Configure controller** button.



For Local operation, press the *Local* button in the **Comm mode** box of the **Control** tab

Other displays on the network will be able to monitor your changes, but will not be able to make parameter changes of their own until **Comm Status** is changed to *Remote*.

For easy identification of the individual T/R controller units, a unique identifier of up to four characters can be entered in the **Unit ID** parameter field by pressing keyboard icon  and entering the desired ID.

Make sure to press the *Apply* button for the controller to apply the changes and stay on the screen or the *OK* button to apply the changes and exit the screen.

Remote Operation

It's easy to monitor and control any unit on the network. Simply connect to the network port. The GDU will automatically display the **Network** screen. Simply press the row that contains the unit that you wish to monitor or control.

As long as the **Comm mode** (in the **Control** display of the **Configure controller** section of the **Setup** menu bar) is set to *Remote*, you can now change its parameters just as if the display was plugged into its local jack. Note that **Comm mode** (local or remote) can only be set from the local port. The Local/Remote parameter can only be setup with the GDU plugged into the Local port.

Each controller on the network must have a unique RS485 address. The addresses are set in the same controller setting screen shown above. Use the **RS485 address** parameter to select a unique GVC address from 10 through 99. Addresses 3 through 9 are reserved for the network GDU.

When you set the **Comm mode** for a GVC to local or remote in the **Setup** you will not have full access to all GVC functions. Some are compatible with both local and remote control, but others are exclusive to one or the other. The table below shows the breakdown by mode.

Function	Local Mode	Remote Mode
Monitor all parameters locally	Yes	Yes
Monitor all parameters remotely	Yes	Yes
Change parameters by PCAMS/2 or Network display/keypad	No	Yes
Change parameters by Local display/keypad	Yes	No
Clear alarm trips by PCAMS/2 or Network display/keypad	No	Yes
Clear alarm trips by Local display/keypad	Yes	No
Control contactor remotely by PCAMS/2	No	Yes
Control contactor remotely by Network display/keypad	Turn off only	Yes
Control contactor by Local display/keypad	Yes	Yes
Change status to local by PCAMS/2 or Network display/keypad	NA	No
Change status to local by Local display/keypad	NA	Yes

ExtDis (External Discrete) Operation

This option should be selected if an external Local – Remote switch is to be used with an external discrete ON signal. The PCAMS, DCSi, or a network GDU cannot turn the controller ON or OFF in this mode. However,

other parameters can still be modified by the PCAMS or DCSi. Go to the **Control** screen. In the **Comm mode** box, press the *ExtDis* button. With this option the terminals functions are as follows:

- Terminal 51: This will be the input terminal for the Local - Remote switch. If 120 VAC is present on the terminal, the unit is in Remote. If there is no voltage on the terminal, the unit is in Local. If the unit is in Local, the only way to energize the HV and to change parameters is from the keypad/ display module in the local port. The network port or the external discrete turn on devices connected to Terminal 48 (Remote On) will not initiate any changes. If the unit is in Remote, the only way to energize the unit is by the external discrete devices connected to Terminal 48. The On/Off button on the keypad in the local port as well as the On/Off command from any other network device will not function. The other network devices will still be able to make changes to other control parameters. The Remote Enable function of Terminal 29 will still function as an electrical permissive in either Local or Remote.
- Terminal 48: This terminal will be used as the Remote On input. It is only functional when voltage is also applied to terminal 51, thereby placing the unit in Remote. When a sustained 120 VAC is applied, the controller will turn on. Removal of this maintained 120 VAC will turn the HV off. The unit will not turn on if 120 VAC is applied at terminal 48 (in Ext. Dis. Mode) and 120 VAC is not present at Terminal 51 (thereby putting the unit in Local).
- Terminal 29: This terminal is used as the Remote Enable. 120 VAC must be applied to this terminal in order for the unit to operate, regardless of whether it is in Local or Remote. Removal of the 120 VAC from terminal 29 will turn the unit off. Re-applying the voltage will not turn the unit on again. If the user does not wish to use the ENABLE function, then it can be enabled all the time by connecting a jumper from terminal 28 to terminal 29.

If the unit is switched from Remote to Local, it will continue in the same state of energization. Meaning if the unit is Off in Remote, then switched to Local, it will stay off. If it is On in Remote, then switched to Local, it will stay on. However, if the unit is switched from Local to Remote, then the unit will follow the state of energization defined by the voltage on Terminal 48. If there is no 120 VAC applied, the unit will turn off. If there is 120 VAC applied, the unit will turn on.

ExtNet (External Network) Operation

This option also allows the use of an external Local – Remote switch. The features and terminal definitions are the same as the *Ext.Dis.* option, however if the external switch is in the Remote position, the controller can only be energized over the network port by either a PCAMS, DCSi or network display. Go to the **Control** screen. In the **Comm mode** box, press the *ExtNet* button. With this option the terminals functions are as follows:

- Terminal 51: This will be the input terminal for the Local - Remote switch. If 120 VAC is present on the terminal, the unit is in Remote. If there is no voltage on the terminal, the unit is in Local. If the unit is in Local, the only way to energize the HV and to change parameters is from the keypad/ display module in the local port. The network port or the external discrete turn on devices connected to Terminal 48 (Remote On) will not initiate any changes. If the unit is in Remote, the only way to energize the unit is by the network devices connected to the network port. The On/Off button on the keypad in the local port as well as the external discrete devices connected to Terminal 48 will not function. The Remote Enable function of Terminal 29 will still function as an electrical permissive (safety interlock) in either Local or Remote.
- Terminal 48: This terminal is not functional when in Ext.Net.
- Terminal 29: This terminal is used as the Remote Enable. 120 VAC must be applied to this terminal in order for the unit to operate, regardless of whether it is in Local or Remote. Removal of

the 120 VAC will turn the unit off. Re-applying the voltage will not turn the unit on again.

If the unit is switched from Remote to Local, it will continue in the same state of energization. Meaning if the unit is Off in Remote, then switched to Local, it will stay off. If it is On in Remote, then switched to Local, will stay on. If the unit is Off in Local, then switched to Remote, it will stay off. If it is On in Local, then switched to Remote, it will stay on.

Open Architecture Communications Using the Network Port

The network port is capable of being configured as Modbus RTU protocol. **The Net port protocol** parameter in the **Control** display of the **Configure controller** section of the **Setup** menu bar lets the customer choose which protocol will be used for the RS485 network port.



If *NWL* is selected, the network port will utilize the *NWL* proprietary protocol.

If *Modbus* is selected, the GVC converts the network port from the *NWL* proprietary protocol to a Modbus RTU protocol. In this case the control will not be able to communicate with other *NWL* network devices such as any network GDU, PCAMS, or DCSi. The Net Port parameter must be set to *NWL* for these devices to operate properly.

Optional Fieldbus Converter

If the controller has an optional field bus converter installed on the DSP board, the specific field bus will be designated in the **Fieldbus** display of the **Configure controller** section of the **Setup** menu bar. The type of module is automatically read and cannot be changed by the operator without changing the module.

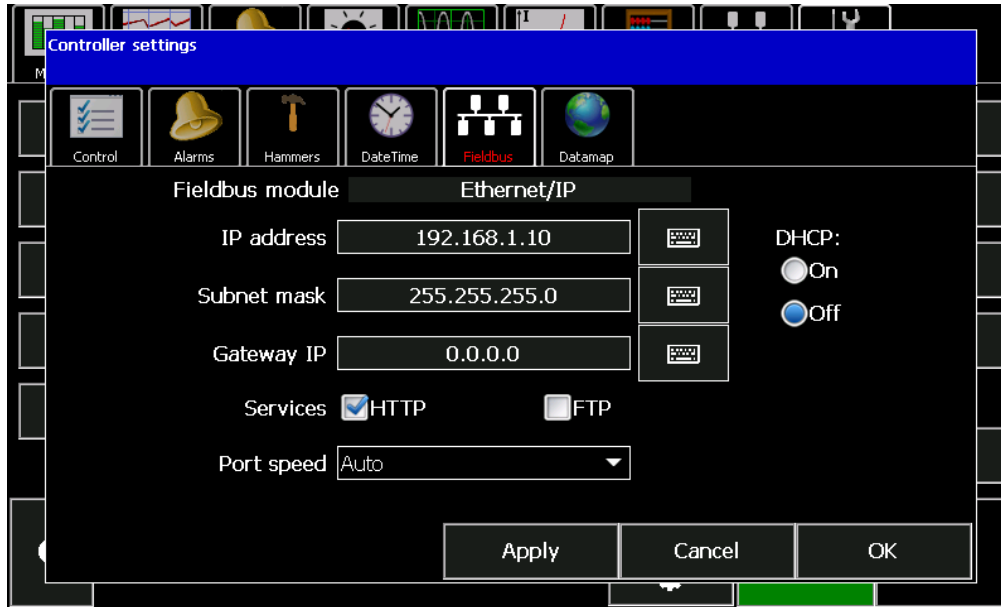

There are other specific protocol parameters that also have to be configured.

Enter the appropriate data for each parameter by pressing the keyboard icon . Consult with your network administrator for the proper parameter values to be entered.

Press the *Apply* button for the controller to apply the changes and stay on the screen or the *OK* button to apply the changes and exit the screen.

The Fieldbus Configuration Screens will vary slightly depending upon the specific Fieldbus being used. The GVC is capable of supporting Ethernet IP, Modbus TCP, Modbus RTU, Profibus DPV1, Profinet, ControlNet, and DeviceNet protocols.

The optional Fieldbus converter is in reality a second network port. There is a parameter for defining which of these network ports will be the master port. The master port is designated as the port which accepts commands and parameter changes via a remote host. The **Remote master** parameter in the **Control** display of the **Configure controller** section of the **Setup** menu bar lets the customer choose which port will be the master.



The parameter choices are:

- NWL Net:* When the **Comm Mode** is set to *Remote*, the fieldbus port will only be able to read data from the controller. It will not be able to write or change parameters. Changes can only be made from a network device on the NWL network port.
- Fieldbus:* When the **Comm Mode** is set to *Remote*, the fieldbus port will be able to read or write data to the controller. Any network device on the NWL network port will only be able to read data from the controller. It will not be able to write data.
- All ports:* When the **Comm Mode** is set to *Remote*, both the NWL network port and the fieldbus port will be able to read and write data to the controller. Note: This mode may lead to contentions on the network and in some cases may lead to parameter/mode settings being continually toggled back and forth as both ports attempt to gain control.

If the fieldbus being used is not Modbus (RTU or TCP), it is possible to configure which parameters the fieldbus will be allowed to write to. This can be used to shorten the length of the write command used by the fieldbus. This setup requires in-depth knowledge of the protocol being utilized.

Go to the **Datamap** display of the **Configure controller** section of the **Setup** menu bar.

Making changes to the datamap will require changes to the HOST device to restore communications. Consult with your network administrator prior to making any changes on this page.

This screen allows you to define which parameters will be capable of being written to by the fieldbus device. Press the individual parameters to select or un-select your choice.

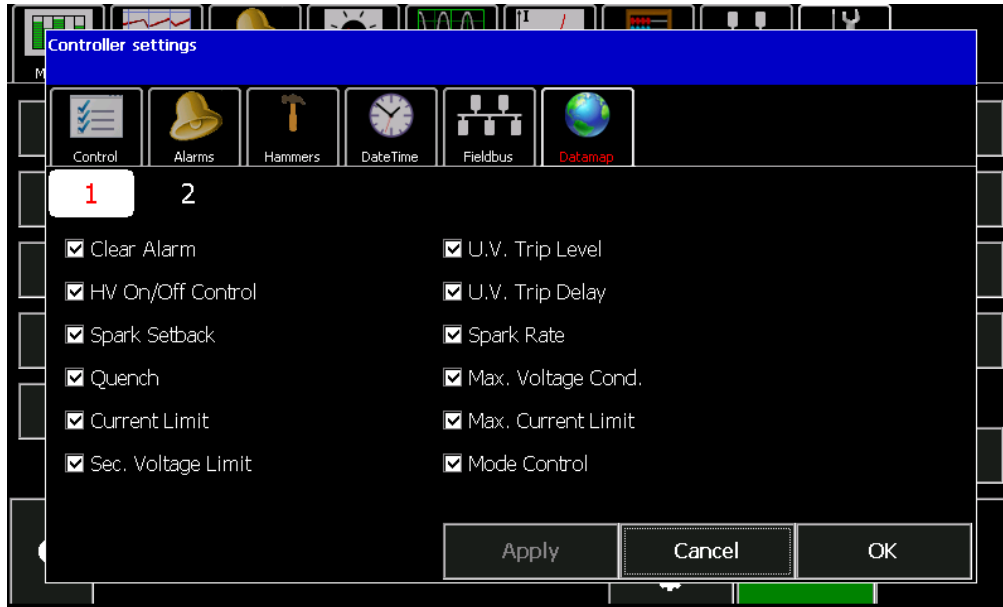

Alarm Configuration

The standard alarms appear on the **Alarm** display screen under the **Configure controller** option of the **Setup** screen. They are:

T/R Over-Current	SCR Over-Temp
T/R High Oil Temp	T/R Low Oil

The alarms are configured by selecting the appropriate alarm from the *Select alarm* pull down option.

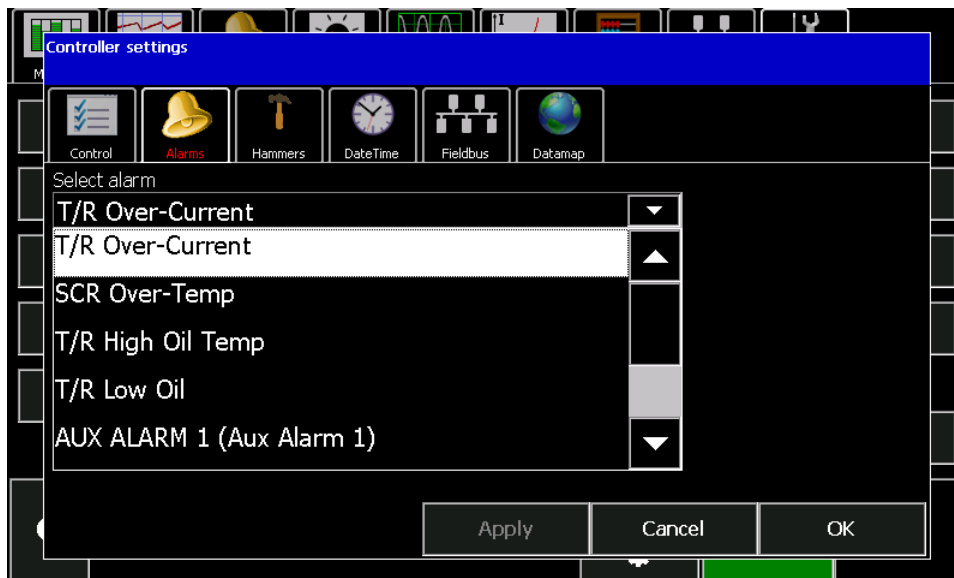

The alarms warn you of serious threats to precipitator operation, including potential damage to the T/R set. They are discrete alarms from external devices that are wired into the appropriate alarm input. The logic for each alarm must be configured.

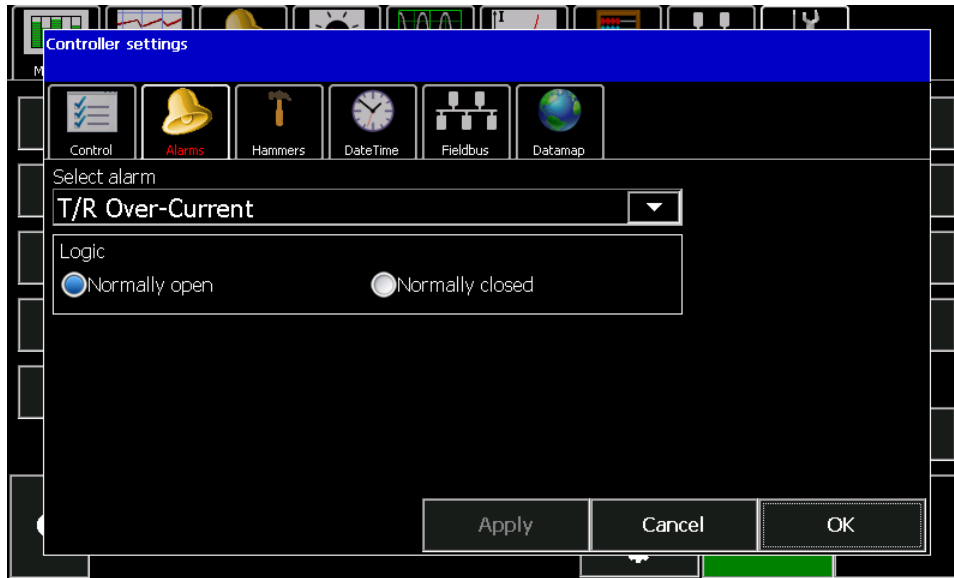

Logic can be set to

- ◆ *Normally open*: A contact closure will activate the alarm.
- ◆ *Normally closed*: A contact opening will activate the alarm.

Type can be set to

- ◆ *Disabled*: ignores any signal at this input.
- ◆ *Display*: shows alarm but does not trip the contactor or a relay
- ◆ *Disp/Relay*: takes the preventive measure of tripping a relay in addition to indicating results
- ◆ *Disp/Relay/Contactor*: adds the capability of de-energizing the power supply by opening the contactor under the specified condition as well as tripping a relay and displaying an alarm

Auxiliary Alarm Configuration

Up to four auxiliary alarms can be configured based on your system and procedures. The auxiliary alarms are completely user-definable and configurable dry-contact inputs (contacts rated 20VDC).

Note: A dry contact means that it is powered by the system.

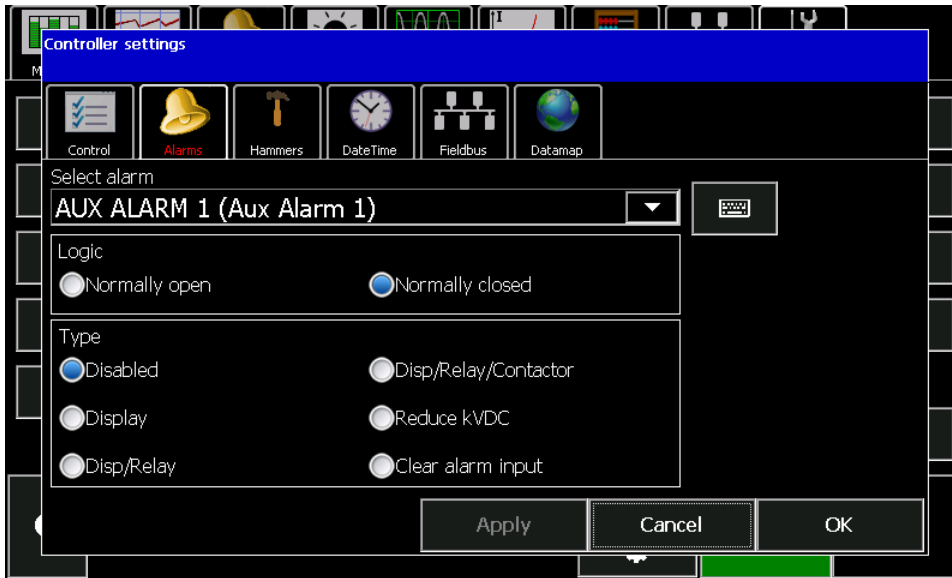

To advance through the auxiliary alarm configuration pages select the appropriate one from the pulldown list. By default, auxiliary alarms are displayed as numbers: *Aux Alarm 1*, *Aux Alarm 2*, etc. You can set them up to display as actual names.

To give each auxiliary alarm a unique but specific ID (i.e. : Fan Failure, Penthouse Temp., etc.), press the keyboard icon , and type in the desired name on the keyboard that appears. Press the submit button when done.

Then set up each parameter as described below.

Logic can be set to

- ◆ *Normally open*: A contact closure will activate the alarm.
- ◆ *Normally closed*: A contact opening will activate the alarm.

Type can be set to

- ◆ *Disabled*: ignores any signal at this input.
- ◆ *Display*: shows alarm but does not trip the contactor or a relay
- ◆ *Disp/Relay*: takes the preventive measure of tripping a relay in addition to indicating results
- ◆ *Disp/Relay/Contactor*: adds the capability of de-energizing the power supply by opening the contactor under the specified condition as well as tripping a relay and displaying an alarm
- ◆ *Reduced kVDC*: When the input contact is closed (or opened, depending on the configuration) the output kVDC will be reduced to a temporary limit. When the contact is reversed the output will ramp up to the original level. The Undervoltage trip is disabled when this feature is active.

When this option is selected an additional control panel will appear to set the Reduced kVDC level that you wish to reduce to when the input contact is closed (or opened, depending on the configuration). Range is 0 – 99%.

- ◆ *Clear alarm input:* When the input contact is closed (or opened, depending on the configuration) the active alarm will be cleared.

Rotating Hammer Rapper Configuration

The GVC can also be configured to operate up to four rotating hammer style rappers with the optional hammer control board. The optional board provides four outputs rated at 120/240 VAC @ 3 A. These outputs are configured by going to the **Hammers** display.

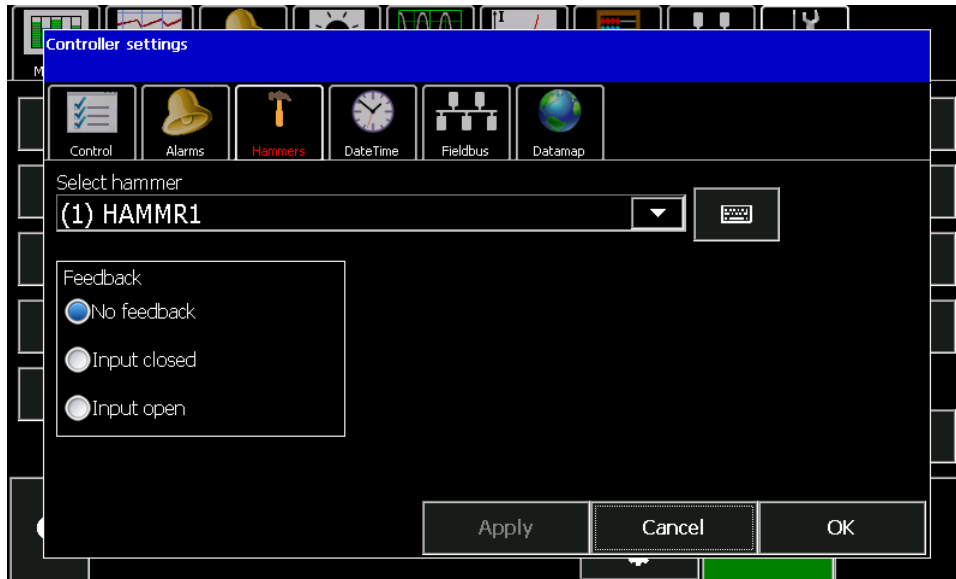

Start by selecting the appropriate hammer output from the **Select hammer** pulldown list. To give each hammer output a unique but specific ID, press the keyboard icon , and type in the desired name on the keyboard that appears. Press the submit button when done.

Next select the **Feedback** logic to be used.

No feedback - The Display Module will not monitor the rotating hammer feedback input.

Input closed - The Display Module will verify the rotating hammer input closes during hammer energization and opens during hammer de-energization. If this condition is not satisfied, the Display Module will indicate a hammer feedback alarm. The high voltage contactor is not affected.

Input open - The Display Module will verify the rotating hammer input opens during hammer energization and closes during hammer de-energization. If this condition is not satisfied, the Display Module will indicate a hammer feedback alarm. The high voltage contactor is not affected.

Date/Time

The Date and Time are used when logging alarms to the SD card. They can be viewed by pressing the **DateTime** button.

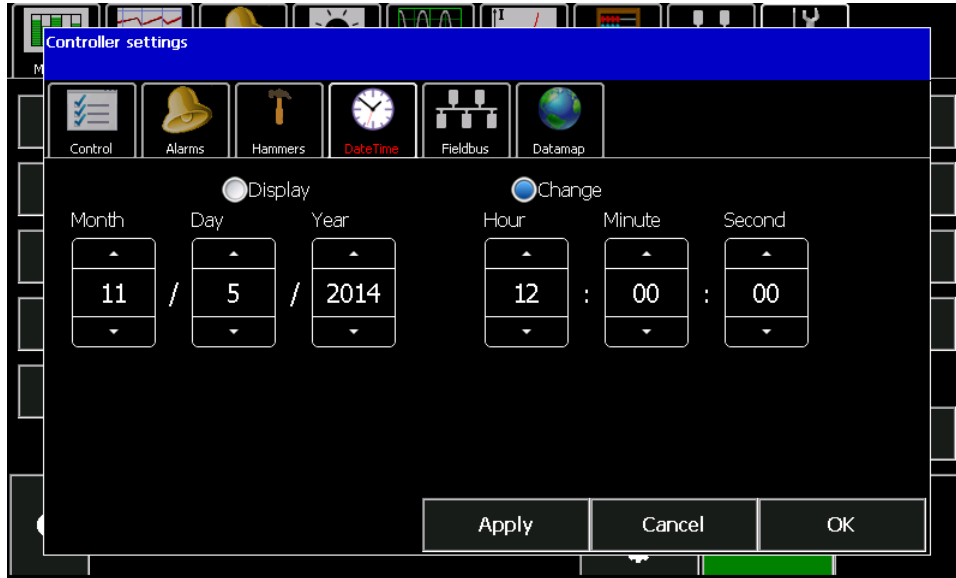

To edit the date or time, press the *Change* button then use the raise or lower arrows to enter the proper values. Press the *Apply* button when complete.

Chapter 6: System Energization and Checkout

Ensuring Proper Operation

In this chapter we will test the GVC and its T/R set for proper operation, then put the system in service.

There should be few, if any problems. In the unlikely event that you find a problem, correct it before proceeding to the next step. If you cannot correct it, contact NWL technical support.

Start-up

All operations will be carried out from the GDU plugged into the Local port. Be sure to watch the analog meters on the T/R set control cabinet carefully where required.

Follow these instructions precisely, in exactly the order given.

The system is now ready to be energized. The following procedure should be followed to ensure that there are no problems with the ESP or the connections to it.

1. Start by temporarily disabling the Undervoltage (U.V.) trip by setting the U.V. Trip setpoint to 0 kV.

Press the Operating Parameter Settings button  located below the Sign On button and next to the HV On button on the bottom section of any of the menu bar screens.

On the next screen press the **Setpoint** button. Go to page two by pressing the **2** button.

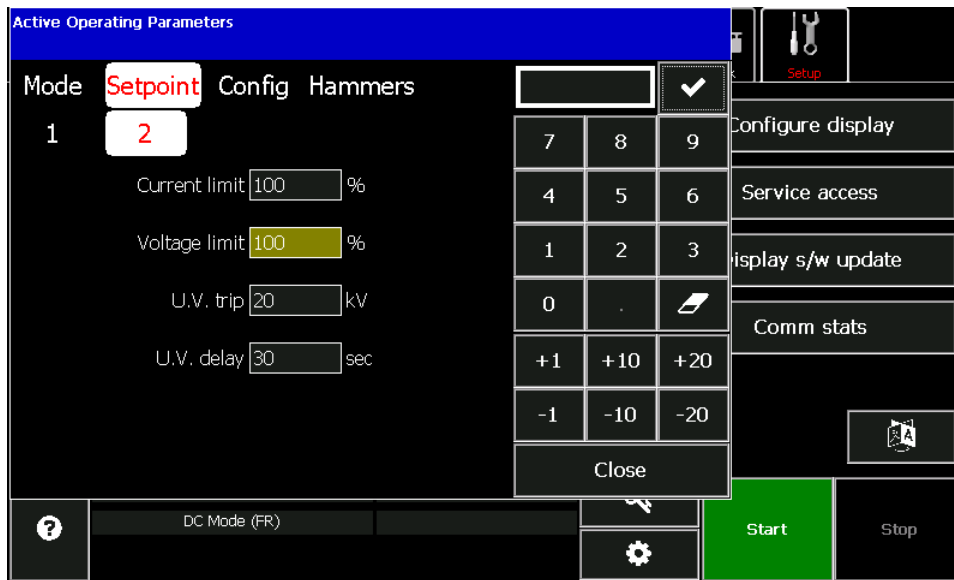

Highlight the U.V. Trip parameter value by touching it. Using the keypad on the right side of the screen press 0 and then press the  button to enter the value. Close the window.

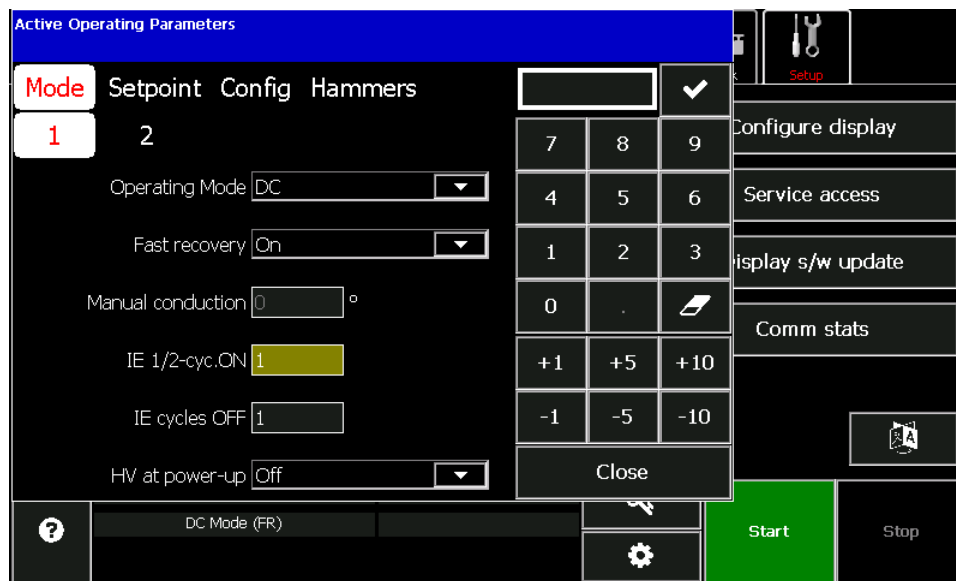

2. Next put the system in manual mode. Press the Operating Parameter Settings  button located below the Sign On button and next to the HV On button on the bottom section of any of the menu bar screens.

On the next screen press the **Mode** button.



Using the pull-down button next to the **Operating Mode** parameter, select *Manual* mode. Press the **Close** button.

The status section at the bottom of the menu bar screens should now display *Manual Mode*.

3. The system is now ready to be energized. The output will be increased manually to verify that no problems exist within the ESP and to limit the output levels until the metering calibration can be verified.
4. Next go to the **Monitor** screen on the menu bar.
5. Press the Green *Start* Button. The main contactor will energize and the HV On icon  will be displayed at the bottom of the screen. The *Start* button will also change color from green to black and the *Stop* button will change color from black to red indicating that the unit is on. Since the controller is in the manual mode awaiting the increase command, all of the meter readings should be zero.
6. Then return to the **Mode** screen shown above. The meter readings table should be visible to the right of the **Mode** screen. This table will be used to monitor the operation of the T/R set while in the Manual mode.
7. Press the **Manual conduction** parameter box to highlight it.
8. Press the  button on the keypad several times to increase the conduction angle while monitoring the meter readings. The meters should all start to increase. If the current meters increase very quickly, but the voltage meters don't, there may be a short in the load. If the voltage meters increase quickly, but the current meters don't, there may be an open in the load. Turn the HV OFF and correct the problem.

If all of the meters increase properly and the system has been calibrated, return the *Operating Mode* to the *DC Mode* (Automatic).

If the meters do not rise, check to make sure the phasing of the trigger board/SCR connection matches that of the 120VAC power to the power supply.

Final Calibration

Calibration is best performed while there is no sparking activity in the precipitator. If the display indicates sparking is taking place, place the controller in the Manual mode and lower the **Conduction angle** until the sparking stops. You can now fine-tune the digital readings to take into account resistor tolerances, wiring runs, and other factors in your T/R set. This will yield much more accurate readings and T/R set control.

We strongly recommend the use of external true RMS meters as references to achieve accuracy.

You can also calibrate the digital readings to match your existing T/R control cabinet analog meters, but this will not be as accurate. It could compromise the GVC's protection of the T/R set.

Press the **Ratings** button on the **Setup** display on the menu bar. The following screen will be displayed.



This screen shows the electrical ratings for the unit. These ratings must be correct to allow the control to maintain operation within safe values.

Make sure that the ratings and other calibration factors are correct per the Ratings verification section of this manual.

Watch the digital readouts in the Act. (Actual) column on the display. These are the real time readings that the GDU will display based on the current feedback levels. Compare them to reference meters (external meters such as a calibrated multimeter or ammeter) as you adjust settings on this screen. By adjusting the values of the Gain parameters you are adjusting the digital reading on the display. The default gain is 50. A gain of 0-49 is a negative gain. A gain of 51-99 is a positive gain. Raising the gain will increase the displayed meter value.

1. Start with **V AC Gain** and adjust it with the ▲ and ▼ buttons until VAC value in the Act column matches the VAC reference meter. This reference meter is usually an external RMS voltmeter placed across the T/R primary.

2. Adjust **A AC Gain** until the AAC value in the Act column matches the AAC reference meter. This reference meter is usually an RMS clamp-on ammeter on one of the main 480 VAC current carrying lines in the controller.
3. Adjust **kVDC Gain** until the kVDC value in the Act column matches the kVDC reference meter. This reference meter is usually a VDC meter placed across the low-end resistor of the voltage divider network. The proper scaling factor must be applied to this reading to obtain the measured kVDC. The scaling factor is the ratio of the Voltage Divider High Resistor/Voltage Divider Lo Resistor. Example: If you read 5 VDC across a 10K low resistor used with an 80 meg high resistor, the GDU should display $5 \times (80/10) = 40$ kVDC.
4. Adjust the **mA DC Gain** until the mADC value in the Act column matches the mADC reference meter. The reference meter is usually a VDC meter placed across the mADC shunt resistor. The proper scaling factor must be applied to obtain the measured mADC. The scaling factor is the VDC measured across the mA shunt resistor divided by the resistance of the mA shunt. Example: If you read 5VDC across a 10 ohm mA shunt resistor, the GDU should display $5\text{VDC}/10 \text{ ohm} = .5$ amps or 500 mADC.

The GVC is now calibrated for the most precise display and safest control of your T/R set's power output. The above configuration should be saved to the SD card for future reference. If the control electronics module is replaced, or if the memory is cleared, these gain settings will be re-loaded to return the system to calibration. The procedure for saving the configuration is explained in the SD card section of this manual.

Starting Automatic Control



The GVC is now fully checked out and calibrated. To start automatic operation:

1. Press the Operating Parameter Settings  button located below the Sign On button and next to the HV On button on the bottom section of any of the menu bar screens.

On the next screen press the  button.

2. Using the pull-down button next to the **Operating Mode** parameter, select *Setpoint* mode. Press the **Close** button.
3. The status section at the bottom of the menu bar screens should now display *Setpoint Mode*.

The output of the GVC will now automatically increase until one of the following occurs:

- A Spark indication  appears at the bottom of the display.
- The T/R reaches its secondary current limit .
- The T/R reaches its secondary voltage limit .
- The Controller reaches maximum Conduction Angle limit.

The display will now show the GVC operating automatically.

Appendix 1 General Wiring Dwg. B131727

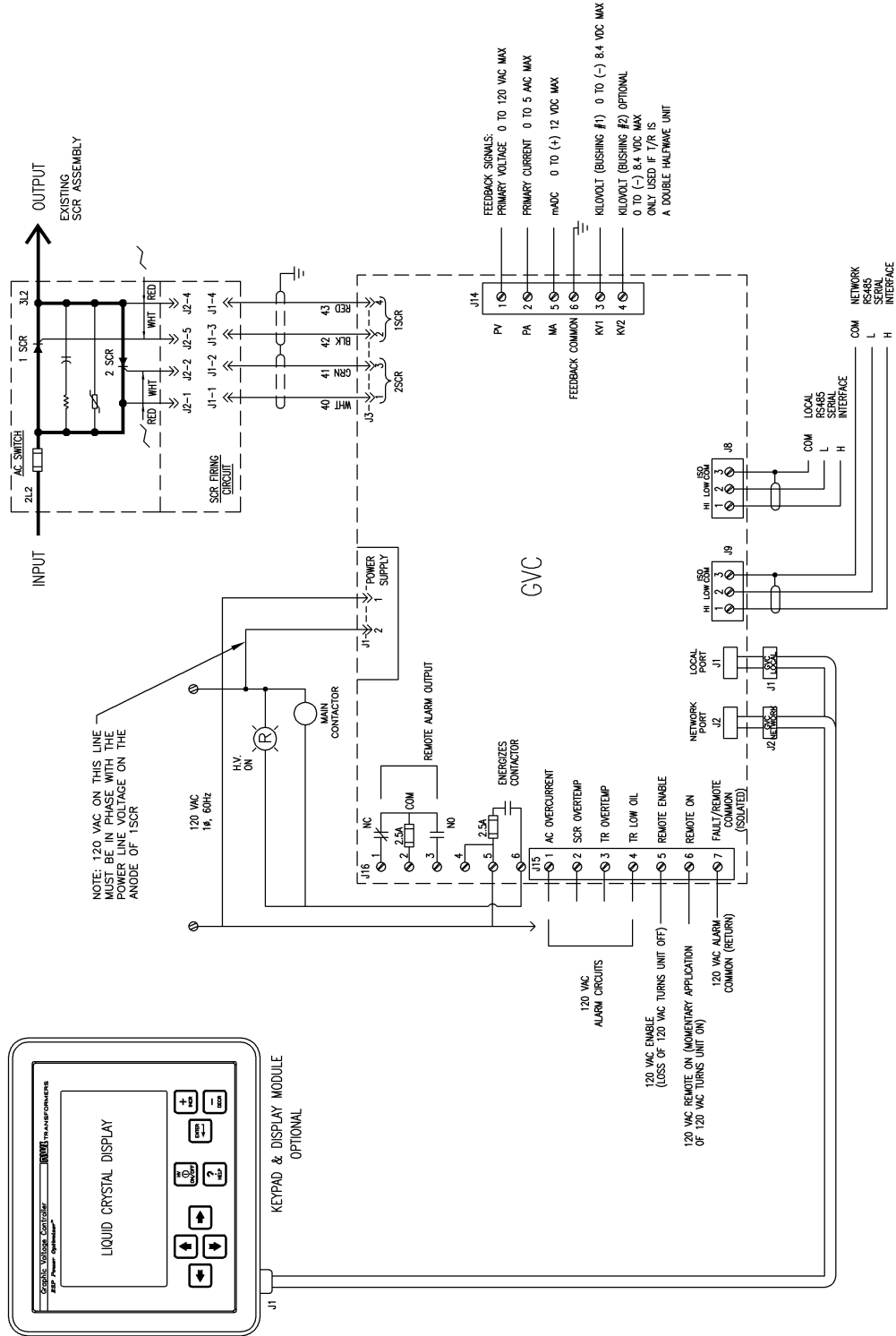

Appendix 1A

Optional Rapper Control Board Wiring

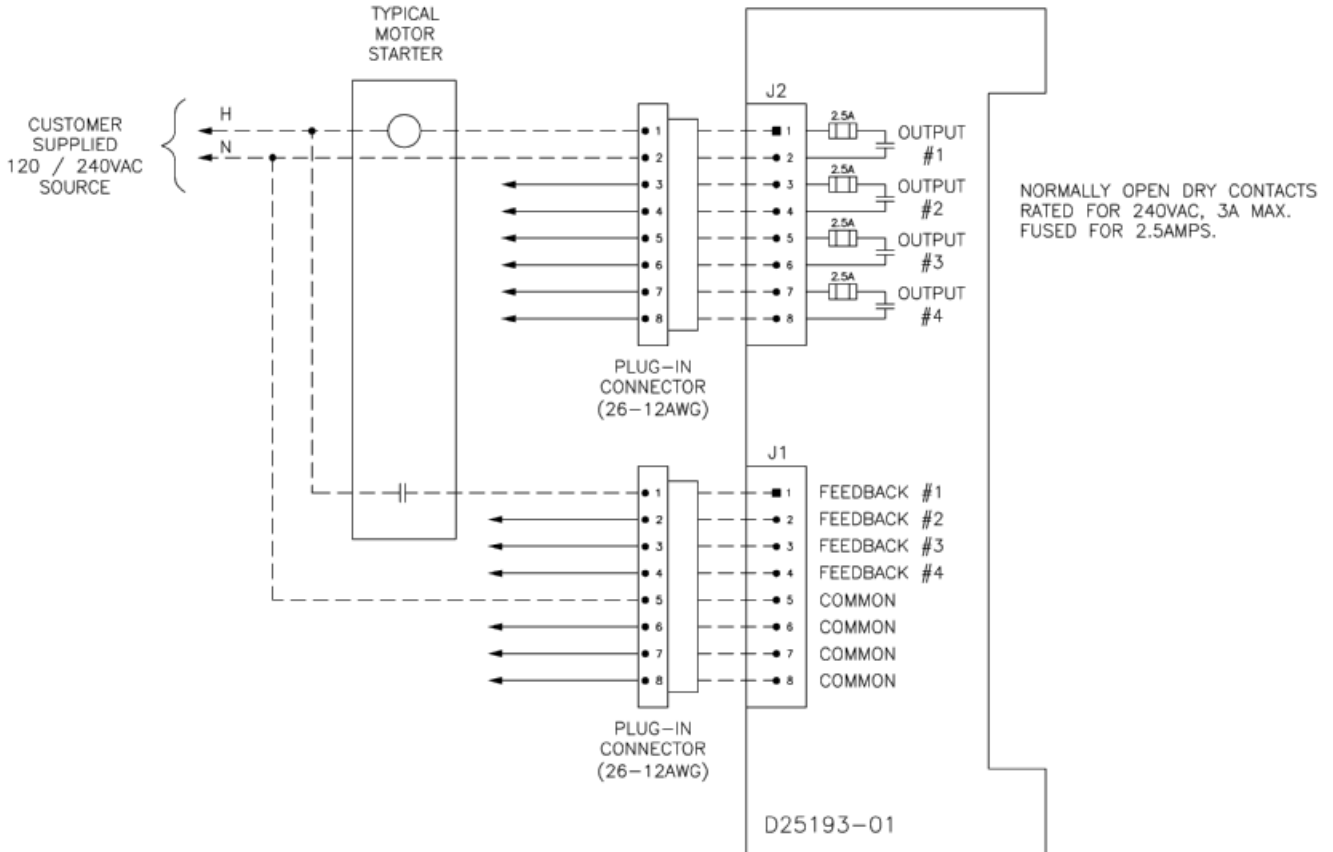

Appendix 2

Control Module Layout

(Not Drawn To Scale)

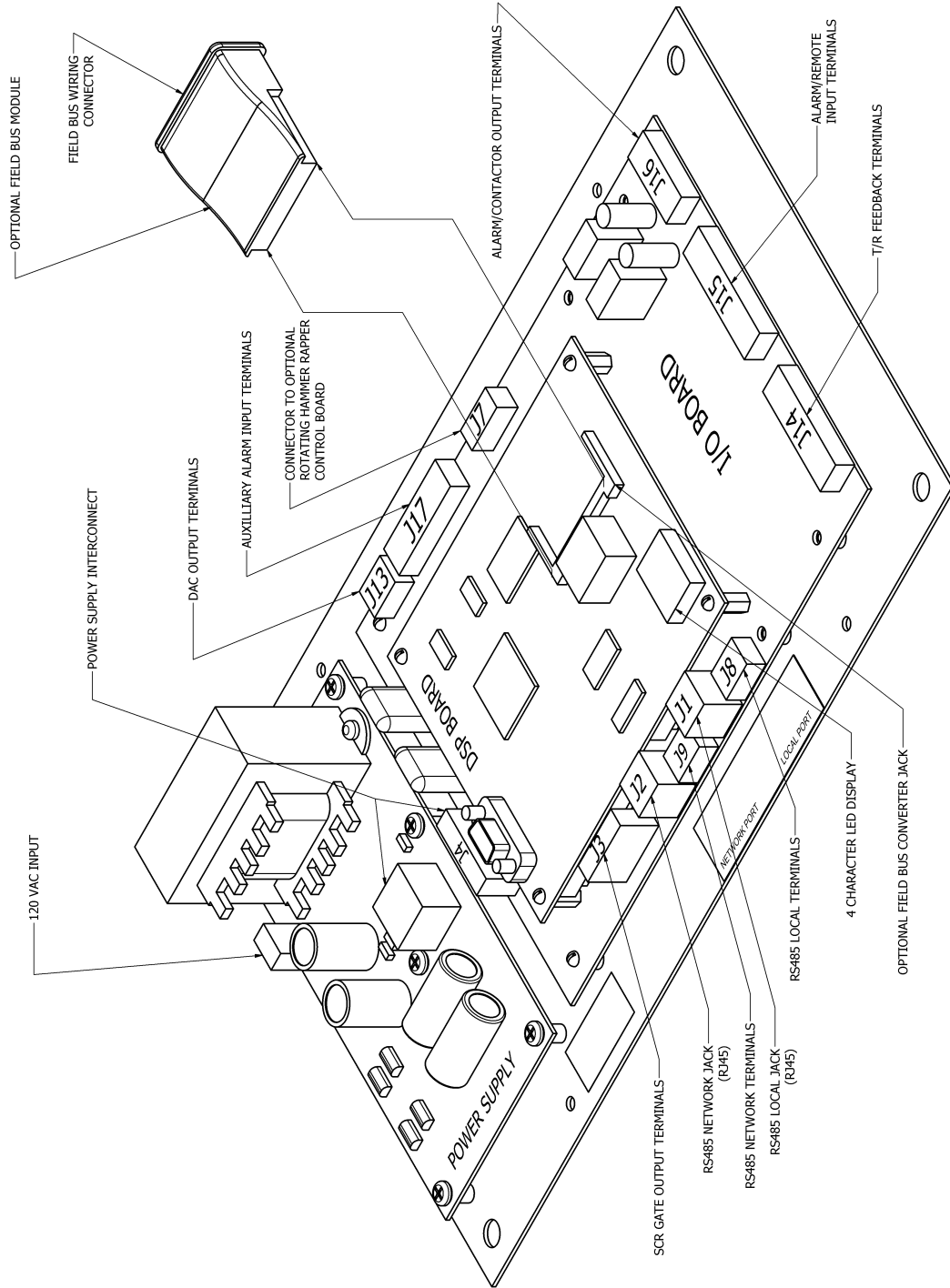

Appendix 3

Keypad/Display Mounting

The next two pages are designed to be 'to scale' mounting templates. Choose the template that matches your display, print the page on 8.5x11, letter-size paper, and affix it to the cabinet or panel.

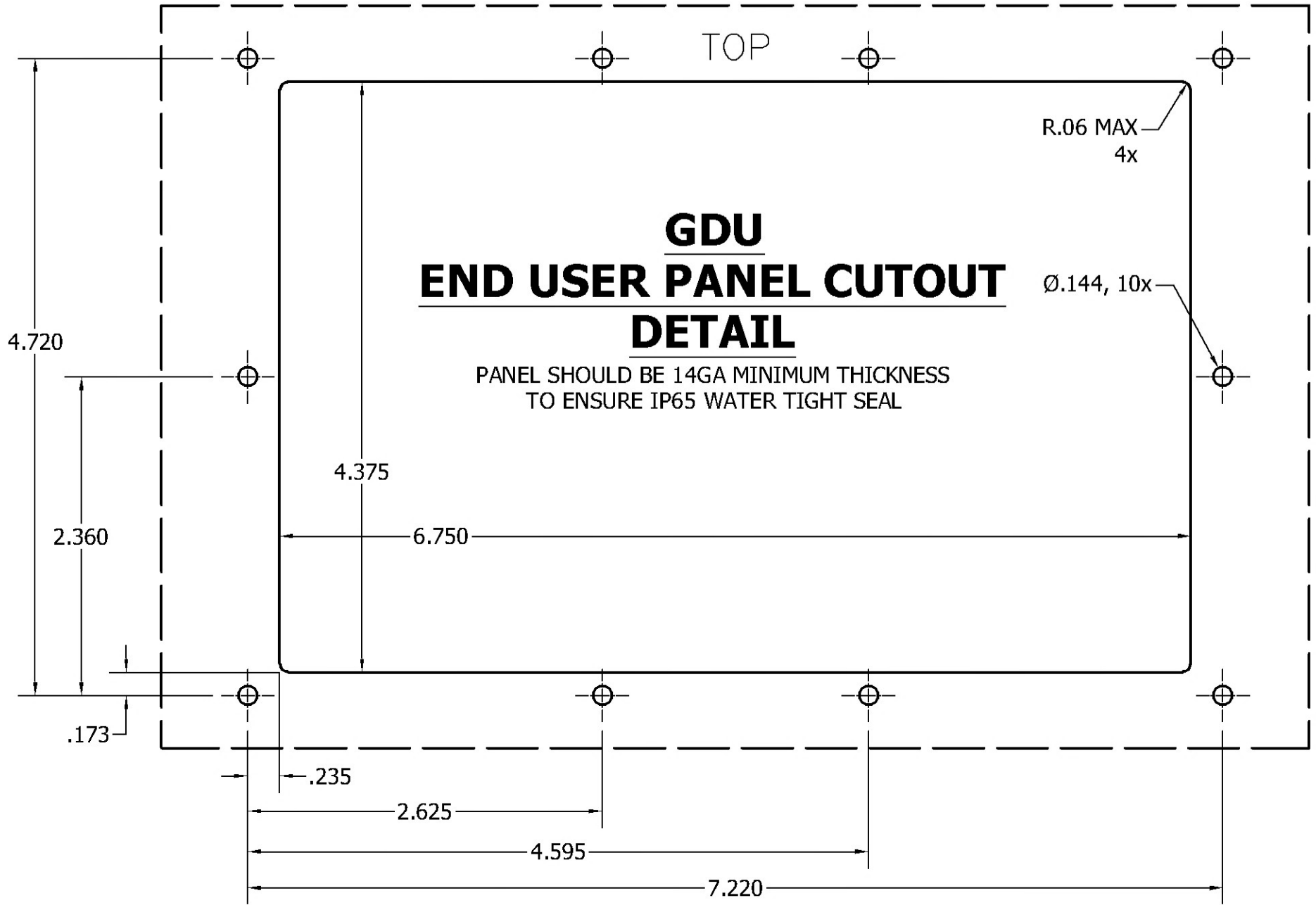

**GDU
END USER PANEL CUTOUT
DETAIL**

PANEL SHOULD BE 14GA MINIMUM THICKNESS
TO ENSURE IP65 WATER TIGHT SEAL

Mounting Template for 855/A

A163239-

Mounting Template for 855/A-HH

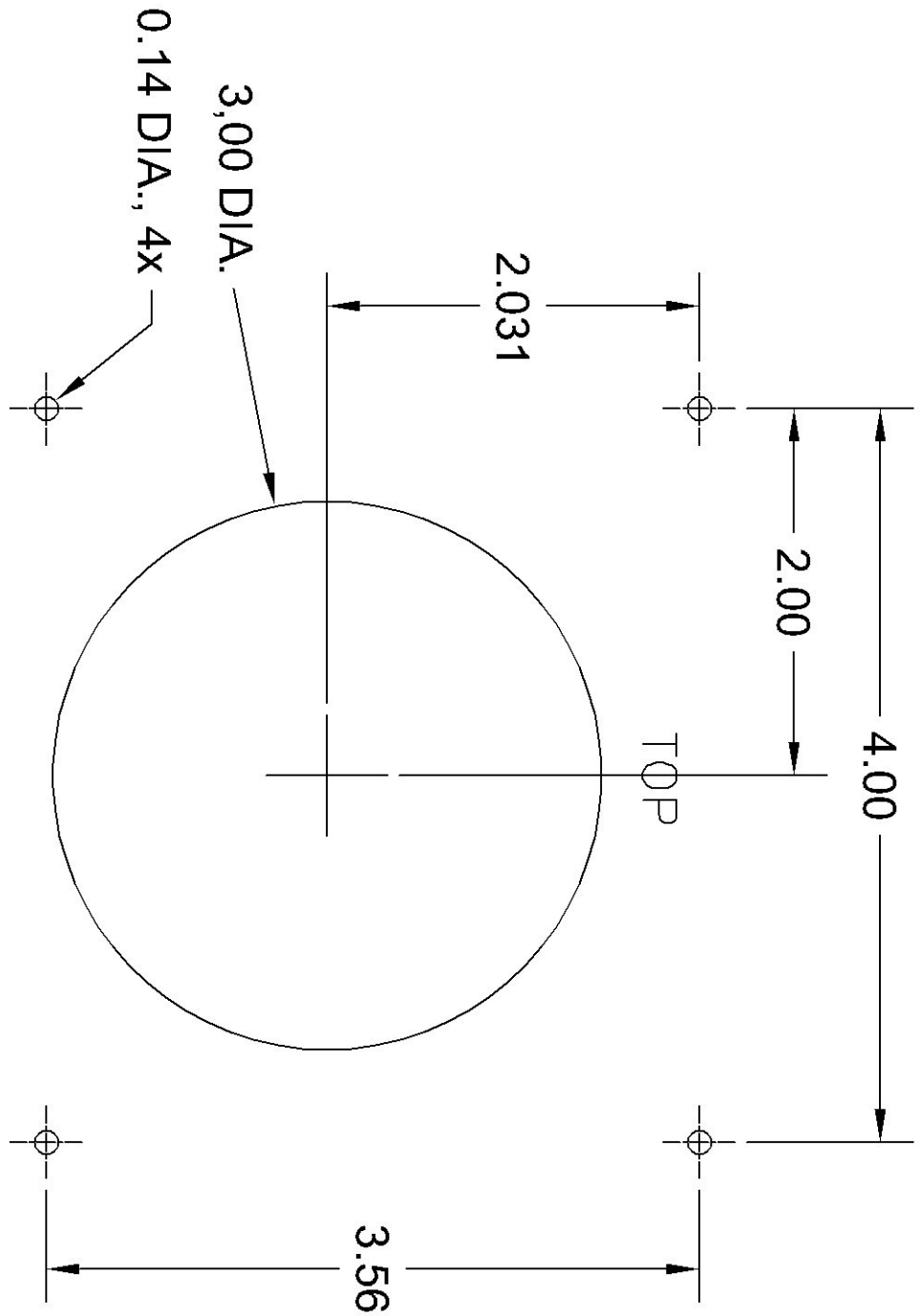

GDU
END USER METER CUTOUT
DETAIL

A163240-

Appendix 4
Trigger Board Mounting
(Not Drawn To Scale)

Mounting Layout
Trigger Board, P/N G70050

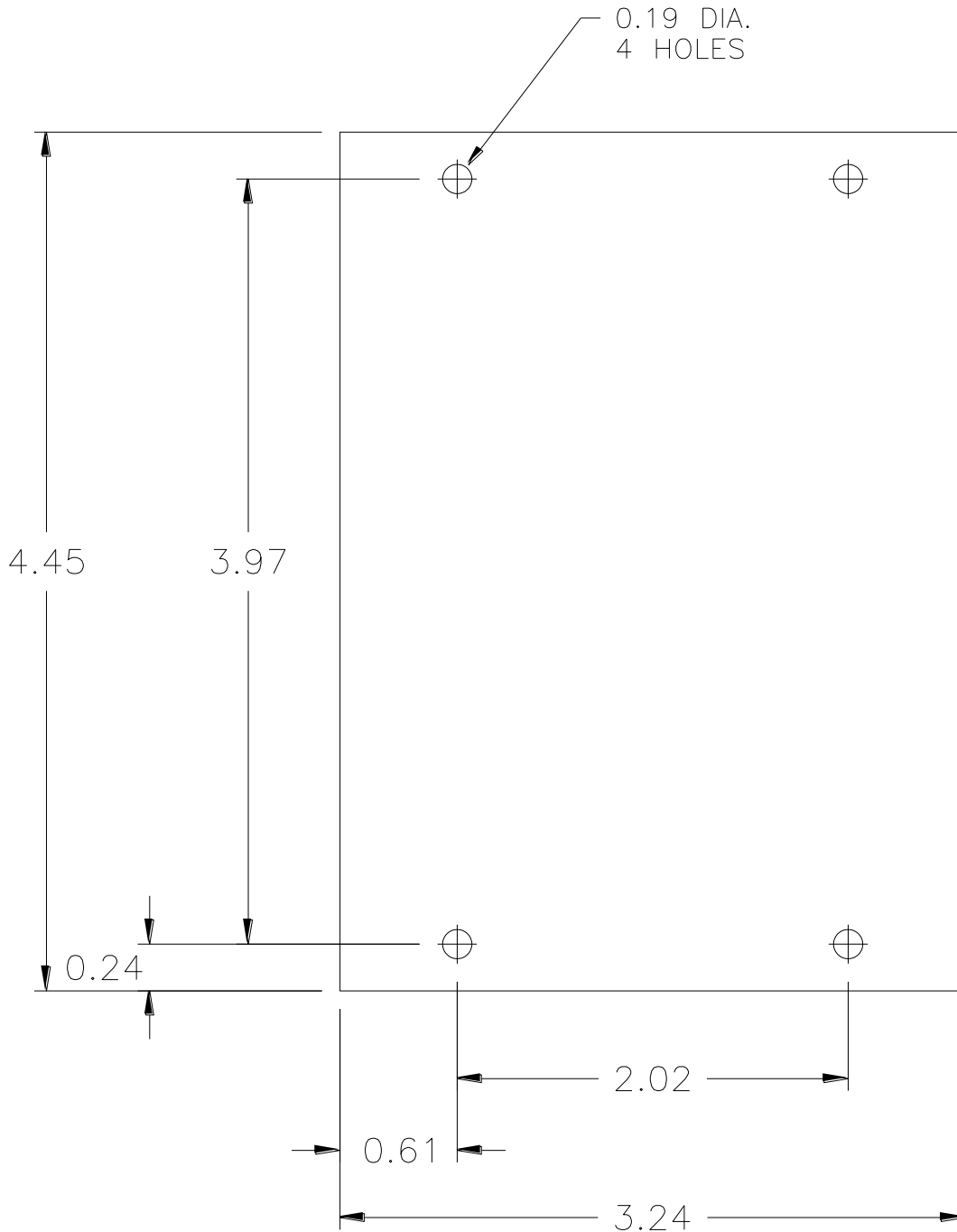

Appendix 5

Control Module Mounting

(Not Drawn To Scale)

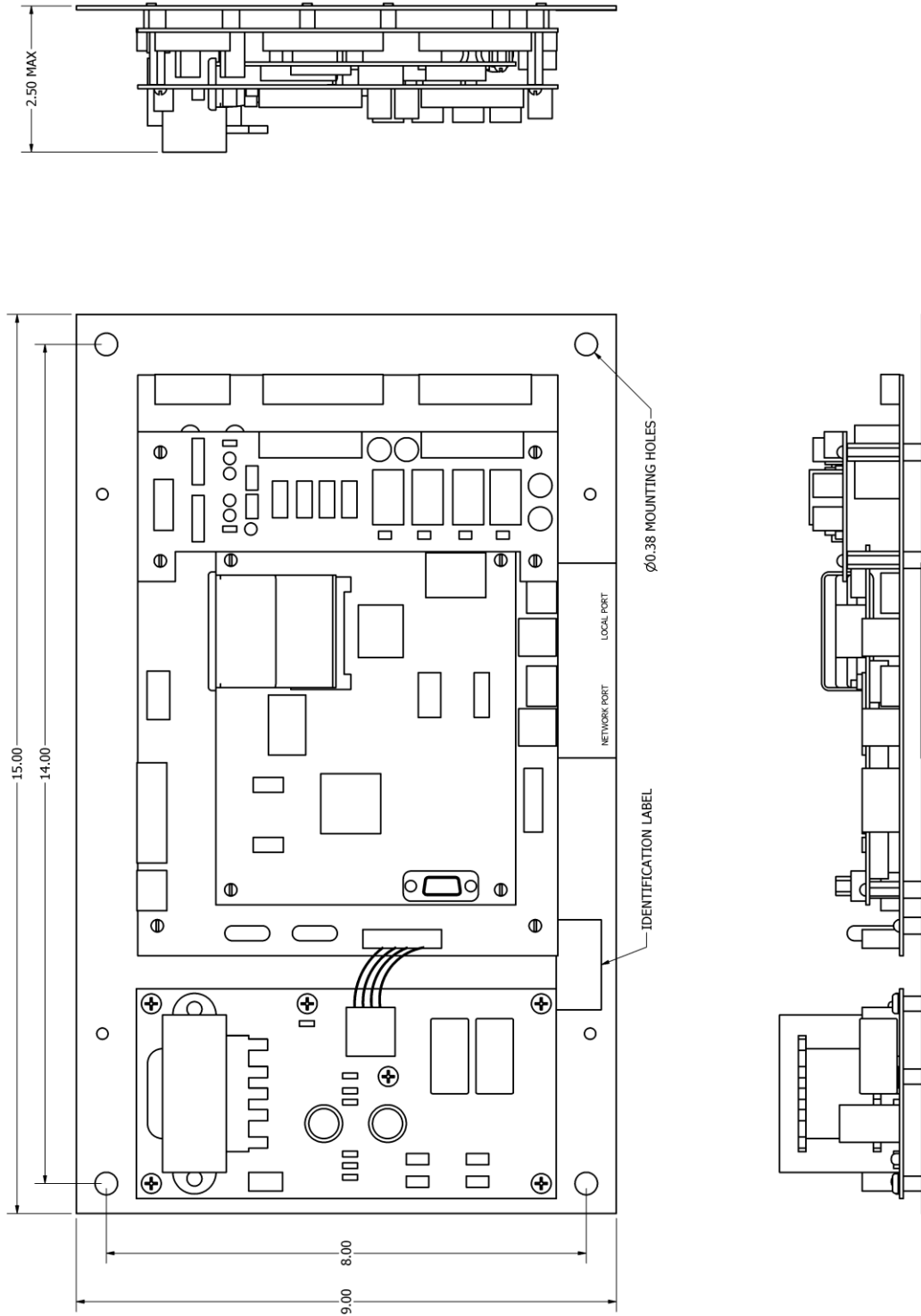

Appendix 6

Connection Cross Reference for Replacing a G20808 with a G20808-01

New Optimizer-DSP G20808-01	Old Optimizer G20808
	TB1
J14-1 Primary Voltage Feedback	1
J14-2 Primary Current Feedback	2
J14-3 kVDC (Bushing #1) Feedback	3
J14-4 kVDC (Bushing #2) Feedback	4
J14-5 mADC Feedback	5
J14-6 Feedback Common/Ground	6
J14-7, 8, 9 Additional Feedback Common/Ground (Internally tied to J14-6)	
J15-1 AC Overcurrent Alarm Input	7
J15-2 SCR Overtemperature Alarm Input	8
J15-3 T/R Overtemperature Alarm Input	9
J15-4 T/R Low Oil Level Alarm Input	10
J15-5 Remote Enable Input	11
J15-6 Remote On Input	12
J15-7 Alarm Common/Return	13
J15-8, 9, 10 Additional Alarm Common/Return (Internally tied to J15-7)	
J16-1 Remote Alarm Relay Contact – N.C.	n/a
J16-2 Remote Alarm Relay Contact – COM.	17
J16-3 Remote Alarm Relay Contact – N.O.	18
J16-4 Option Voltage Source Terminal (Internally tied to J16-5)	n/a
J16-5 Voltage Source for Contactor Coil (120 VAC typ.)	15
J16-6 Output to Energize Contactor Coil	16
	TB2
J17-1 Aux. Alarm #1	1
J17-2 Aux. Alarm #2	2
J17-3 Aux. Alarm #3	3
J17-4 Aux. Alarm #4	4
J17-5 Aux. Alarm Common/Return	5
J17-6, 7, 8 Additional Aux. Alarm Common/Return (Internally tied to J17-5)	