

2

1

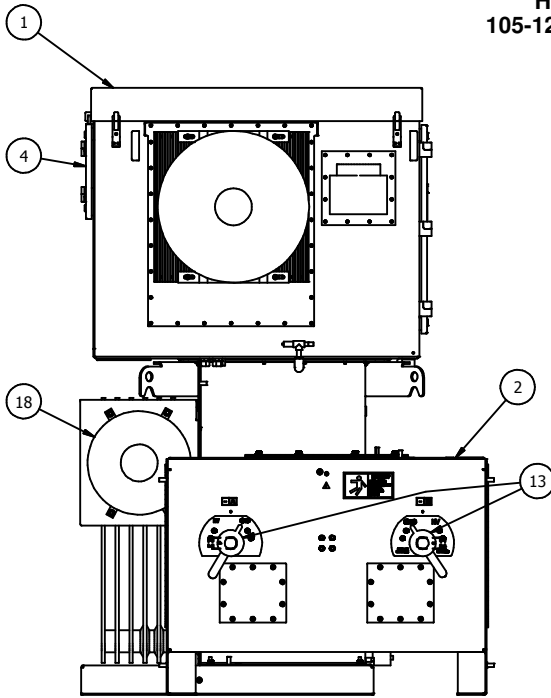

HF ESP, POWERPLUS SERIES 105-120kW UNITS w/SPLITTER SWITCH



FRONT VIEW

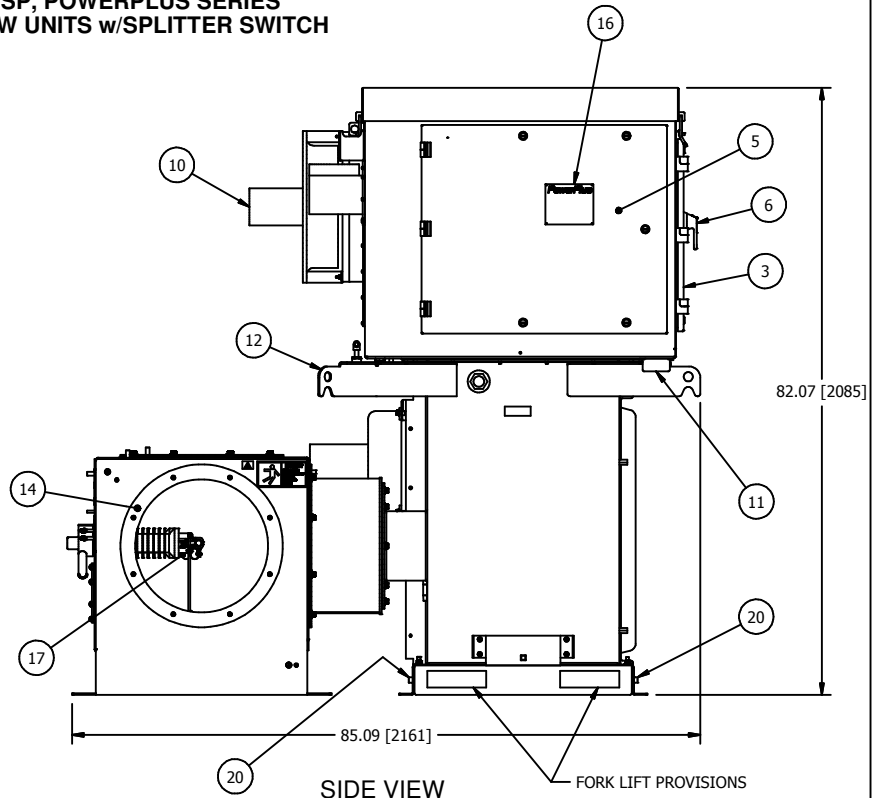

SIDE VIEW

FORK LIFT PROVISIONS

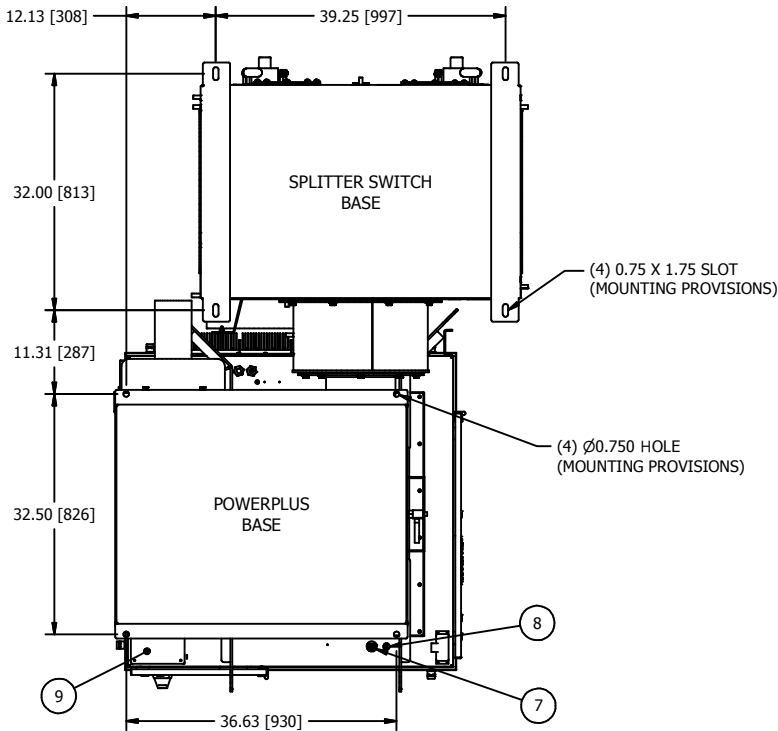

BOTTOM VIEW

- 1 POWERPLUS UNIT
- 2 SPLITTER SWITCH (SHIPS SEPARATELY).
- 3 ACCESS DOOR TO CIRCUIT BREAKER TERMINALS. ALLOW 19" [483] OF CLEARANCE FROM THIS FACE FOR DOOR SWING.
- 4 ACCESS DOOR TO 3 PHASE RECTIFIER ASSEMBLY. ALLOW 19" [483] OF CLEARANCE FROM THIS FACE FOR DOOR SWING.
- 5 ACCESS DOOR TO H.V. TANK AND CONTROL SECTION. ALLOW 37" [940] OF CLEARANCE FROM THIS FACE FOR DOOR SWING.
- 6 INPUT CIRCUIT BREAKER SWITCH HANDLE WITH INTERLOCK PROVISION INSIDE. FOR ACCEPTABLE INTERLOCKS SEE DWG A105811.
- 7 1" [25.4] DIA. CONDUIT HOLE FOR 120V CONTROL WIRING.
- 8 1/2" [12.7] DIA. CONDUIT HOLE FOR LOW VOLTAGE COMMUNICATION AND OPTIONAL TRANSDUCER CONDUIT.
- 9 GLAND PLATE FOR 3 PHASE POWER AND GROUND.
- 10 COOLING FAN FOR IGBT HEATSINK ASSEMBLY.
- 11 EZ SCOPE PORT WITH RJ45 SOCKET FOR KEYPAD DISPLAY CONNECTION AND BNC CONNECTORS FOR MAKING EXTERNAL kV AND mA MEASUREMENTS.
- 12 LIFTING HOOKS (4 PLACES).
- 13 H.V. SWITCH MECHANISM WITH VIEWING WINDOW AND INTERLOCK PROVISIONS. FOR INTERLOCK AND BOLT EXTENSION INFORMATION SEE DWG A105881.
- 14 SIDE EXIT 18" DUCT MOUNTING PROVISION. INCLUDES GASKETS AND 3/8-16 HARDWARE (8) PLACES ON A 20" [508] DIA. B.C. WITH 18" [457] DIA. DUCT OPENING.
- 15 SIDE EXIT 22" [559] ACCESS COVER (NOT SHOWN). INCLUDES GASKETS AND 3/8-16 HARDWARE (8) PLACES ON A 20" [508] DIA. B.C. WITH 18" [457] DIA. DUCT OPENING.
- 16 HIGH VOLTAGE SEMI-OUTDOOR BUSHING, SEE DETAIL 'A' FOR DETAILS.
- 17 RATINGS NAMEPLATE, ALUMINUM PHOTO ETCHED.
- 18 OPTIONAL METRIC ADAPTER FOR H.V. BUSHING CONNECTION. CONVERTS 1/2" NPT TO M20-1.5. SEE DWG A117570.
- 19 RADIATOR COOLING FAN.
- 20 EQUIPMENT SAFETY GROUND TERMINATION, 3/8-16 GROUND BOSS.

NOTES:

1. POWERPLUS MUST BE MOUNTED ON LEVEL SURFACE OR SHIMMED TO WITHIN 1/8" [3.2] RISE PER 12" [305] RUN.
2. COLD ROOF MAY NEED TO BE REINFORCED TO ACCEPT THE WEIGHT OF THE POWERPLUS UNIT.
3. MAXIMUM ALLOWABLE DUCT INTERNAL TEMPERATURE: 122°F (50°C). MAXIMUM ALLOWABLE DUCT INTERNAL PRESSURE: 1 PSI (2.04" Hg). THE INSTALLER MUST USE AN ENTRANCE BUSHING IN ROOF TO MEET THESE SPECIFICATIONS.
4. POWERPLUS MUST BE GROUNDED TO THE COLD ROOF BY THE END USER. REFER TO DWG B126972 FOR GROUNDING DETAILS.
5. ALLOW 120" MINIMUM CLEARANCE ABOVE THE FLOOR TO LIFT AND REMOVE THE T/R RIG ASSEMBLY FROM THE OIL TANK. CLEARANCE DOES NOT INCLUDE RIGGING HEIGHT.

APPROX. WEIGHT WITH SPLITTER SWITCH: 2625bs (1191kg).
 DIELECTRIC FLUID VOLUME: 100gal (379L).
 FINISH: ENAMEL, ASA 61, APPROX. RAL 7042.
 TANK AND CONTROL ENCLOSURE RATED NEMA 4/IP56.

DATA SHEET: ESP105-120SP-C
 REVISION DATE: 01/17/11

ALL DIMENSIONS IN INCHES [mm]

APPROVED BY: HH