

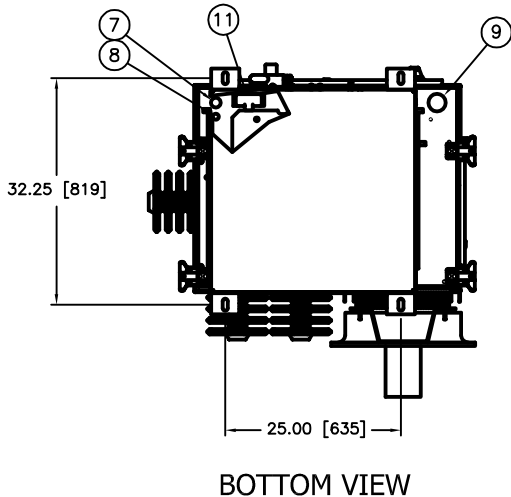

**HF ESP, POWERPLUS SERIES
56 & 70 kW UNIT WITH DISCONNECT GROUND SWITCH**

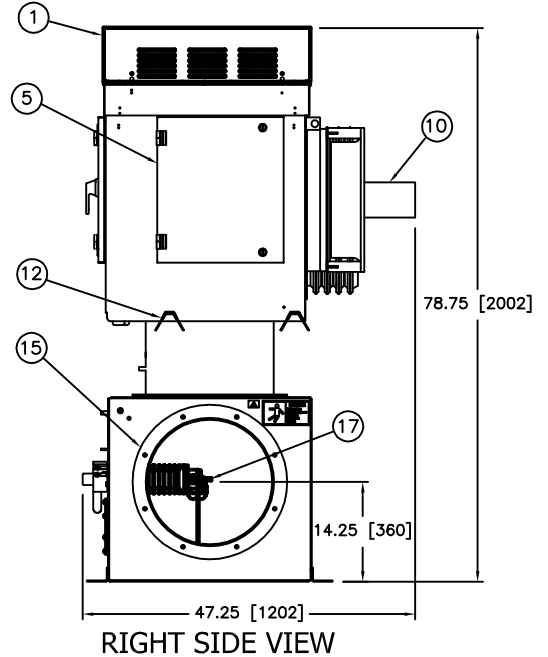
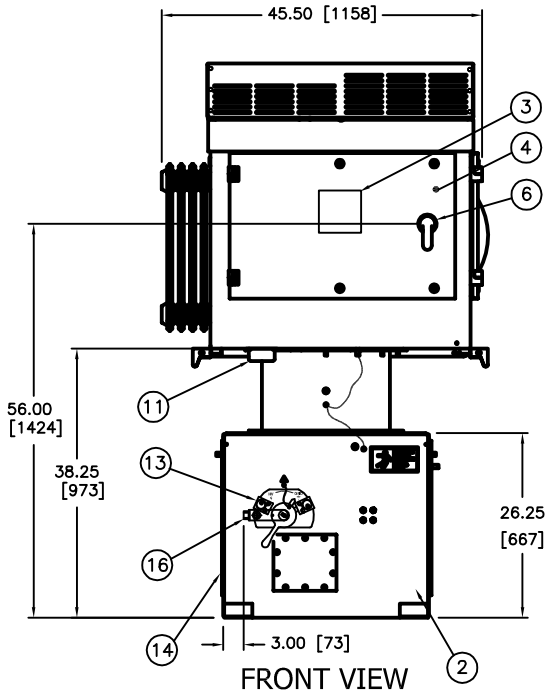

- ① POWERPLUS UNIT.
- ② DISCONNECT GROUND SWITCH – USED TO DISCONNECT AND GROUND THE ESP.
- ③ RATINGS NAMEPLATE, ALUMINUM, PHOTO ETCHED.
- ④ SWITCH GEAR AND CONTROL SECTION WITH HINGED DOOR. ALLOW 33"[838] OF CLEARANCE FROM THIS FACE FOR DOOR SWING.
- ⑤ POWER ELECTRONICS SECTION WITH HINGED DOOR. ALLOW 19"[483] OF CLEARANCE FROM THIS FACE FOR DOOR SWING.
- ⑥ INPUT CIRCUIT BREAKER SWITCH HANDLE WITH INTERLOCK PROVISION INSIDE. FOR ACCEPTABLE INTERLOCK SEE DWG A105811.
- ⑦ 1"[25.4] DIA CONDUIT HOLE FOR 120V CONTROL WIRING.
- ⑧ 1/2"[12.7] DIA CONDUIT HOLE FOR LOW VOLTAGE TRANSDUCER AND COMMUNICATION LINK CONDUIT.
- ⑨ 2"[51] DIA CONDUIT HOLE FOR 3 PH POWER AND GROUND.
- ⑩ COOLING FAN FOR IGBT HEAT SINK ASSEMBLY.
- ⑪ EZ SCOPE PORT WITH RJ45 SOCKET FOR KEYPAD DISPLAY CONNECTION AND BNC CONNECTORS FOR MAKING EXTERNAL kV AND mA MEASUREMENTS.
- ⑫ LIFTING HOOKS (4 PLACES).
- ⑬ H.V SWITCH MECHANISM WITH VIEWING WINDOW AND INTERLOCK PROVISIONS. FOR INTERLOCK AND BOLT EXTENSION INFO SEE DWG A105811.
- ⑭ SIDE EXIT 18" DUCT MOUNTING PROVISION. INCLUDES GASKETS AND 3/8–16 HARDWARE 8 PLACES ON A 20"[508] DIA B.C. WITH 18"[457] DIA DUCT OPENING.
- ⑮ SIDE EXIT 22" ACCESS COVER (NOT SHOWN). INCLUDES GASKETS AND 3/8–16 HARDWARE 8 PLACES ON A 20"[508] DIA B.C. WITH 18"[457] DIA DUCT OPENING.
- ⑯ 1/2"NPT OUTPUT CONNECTION TAB TO ESP.
- ⑰ OPTIONAL METRIC ADAPTER FOR H.V. OUTPUT CONNECTION. CONVERTS 1/2"NPT TO M20–1.5. SEE A117570.

NOTES:

1. POWERPLUS MUST BE MOUNTED ON A LEVEL SURFACE OR SHIMMED TO WITHIN 1/8"[3.2] RISE PER 12"[305] RUN.
2. COLD ROOF MAY NEED TO BE REINFORCED TO ACCEPT THE WEIGHT OF THE POWER PLUS UNIT.
3. MAXIMUM ALLOWABLE DUCT INTERNAL TEMPERATURE: 122°F (50°C). MAXIMUM ALLOWABLE DUCT INTERNAL PRESSURE: 1PSI (2.04"Hg. THE INSTALLER MUST USE AN ENTRANCE BUSHING IN THE ROOF.
4. POWERPLUS MUST BE GROUNDED TO THE COLD ROOF BY THE END USER. REFER TO DWGB125481 FOR GROUNDING DETAILS.

APPROX WEIGHT WITH DISCONNECT GND SWITCH: 1300lbs, 590kg
 DIELECTRIC FLUID VOLUME: 29gal, 110L
 FINISH: ENAMEL, ASA 61, APPROX. RAL 7042
 TANK AND CONTROL ENCLOSURE ARE SEALED UNITS RATED NEMA 4/IP56
 ALL DIMENSIONS IN INCHES FOLLOWED BY [mm].

DATA SHEET: ESP56–70DS
 REVISION DATE: 06/05/09
 APPROVED BY: HH