

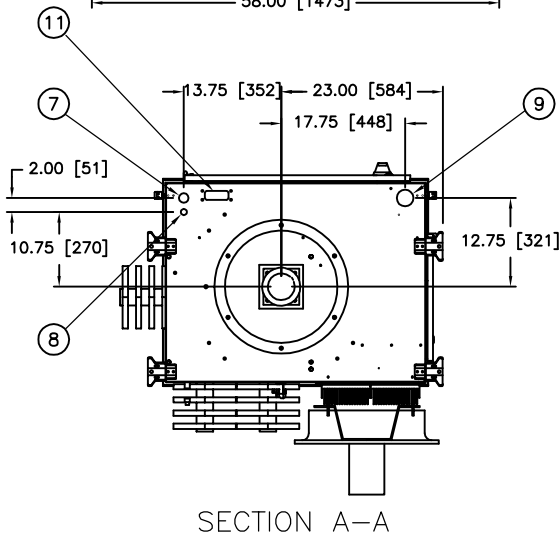

**HF ESP, POWERPLUS SERIES
56 & 70 kW UNITS WITH LOW PROFILE SPLITTER SWITCH**

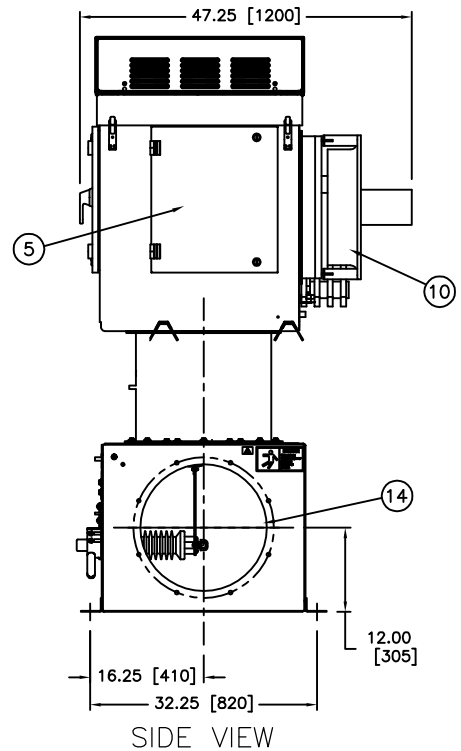
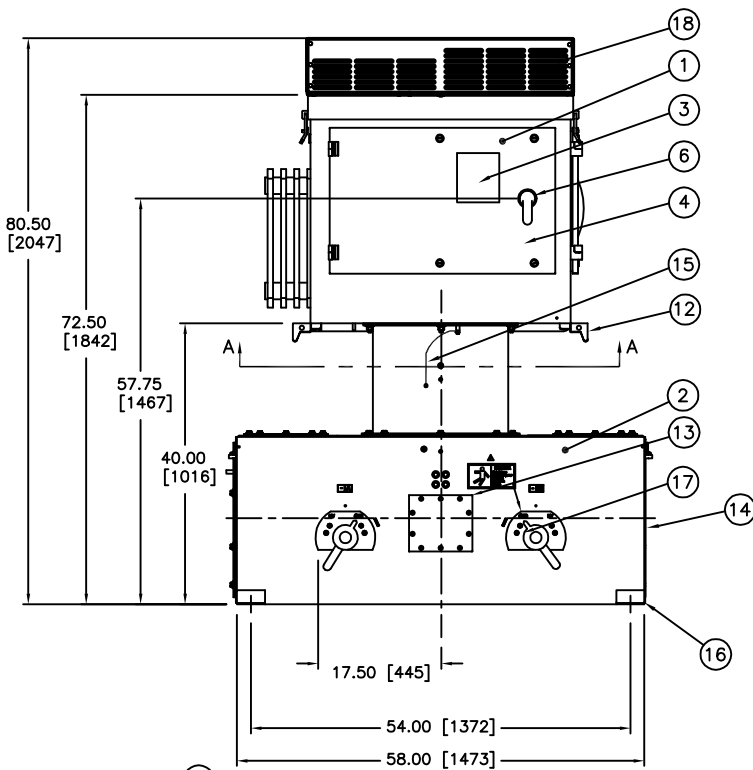

SECTION A-A

NOTES:

1. SPLITTER SWITCH WILL BE SHIPPED SEPARATE FROM POWERPLUS UNIT AND MUST BE ASSEMBLED AT THE SITE.
2. POWERPLUS UNIT WILL BE SHIPPED MOUNTED TO A TEMPORARY SHIPPING SPOOL. REFER TO MANUAL FOR SWITCH MOUNTING INSTRUCTIONS.
3. POWERPLUS AND SWITCH MUST BE MOUNTED ON A LEVEL SURFACE OR SHIMMED TO WITHIN 1/8"[3.2] RISE PER 12"[305] RUN.
4. COLD ROOF MAY NEED TO BE REINFORCED TO ACCEPT THE WEIGHT OF THE POWER PLUS UNIT.
5. MAXIMUM ALLOWABLE DUCT INTERNAL TEMPERATURE: 122°F (50°C). MAXIMUM ALLOWABLE DUCT INTERNAL PRESSURE: 1 PSI (2.04"Hg). THE INSTALLER MUST USE AN ENTRANCE BUSHING IN ROOF TO MEET THESE SPECIFICATIONS
6. SWITCHBOX MUST BE GROUNDED TO THE COLD ROOF BY THE END USER. REFER TO DWG B125481 FOR GROUNDING DETAILS.
7. INTEGRATED AUTO TRANSFORMER OPTION IS NOT AVAILABLE WITH A SPLITTER SWITCH. AUTO TRANSFORMER MUST BE SEPARATE.

- ① POWERPLUS UNIT.
- ② SPLITTER SWITCH – USED TO DISCONNECT AND GROUND EACH FIELD SEPARATELY.
- ③ RATINGS NAMEPLATE, ALUMINUM PHOTO ETCHED.
- ④ SWITCH GEAR AND CONTROL SECTION WITH HINGED DOOR. ALLOW 33"[838] OF CLEARANCE FROM THIS FACE FOR DOOR SWING.
- ⑤ POWER ELECTRONICS SECTION WITH HINGED DOOR. ALLOW 19"[483] OF CLEARANCE FROM THIS FACE FOR DOOR SWING.
- ⑥ INPUT CIRCUIT BREAKER SWITCH HANDLE WITH INTERLOCK PROVISION INSIDE. FOR ACCEPTABLE INTERLOCK SEE DWG A105811.
- ⑦ 1"[25.4] DIA CONDUIT HOLE FOR 120V CONTROL WIRING.
- ⑧ 1/2"[12.7] DIA CONDUIT HOLE FOR LOW VOLTAGE COMMUNICATION AND OPTIONAL TRANSDUCER CONDUIT.
- ⑨ 2"[51] DIA CONDUIT HOLE FOR 3 PHASE POWER AND GROUND.
- ⑩ COOLING FAN FOR IGBT HEATSINK ASSEMBLY.
- ⑪ EZ SCOPE PORT WITH RJ45 SOCKET FOR KEYPAD DISPLAY CONNECTION AND BNC CONNECTORS FOR MAKING EXTERNAL kV AND mA MEASUREMENTS.
- ⑫ LIFTING HOOKS (4 PLACES).
- ⑬ H.V SWITCH MECHANISM WITH VIEWING WINDOW AND INTERLOCK PROVISIONS. FOR INTERLOCK AND BOLT EXTENSION INFO SEE DWG B105881.
- ⑭ SIDE EXIT DUCT MOUNTING PROVISION WITH 22"[558] O.D. COVER PLATE. INCLUDES GASKETS AND 3/8-16 HARDWARE 8 PLACES ON A 20"[508] DIA B.C. WITH 18"[457] DIA DUCT OPENING.
- ⑮ SS GROUND CABLE TO GROUND EACH SECTION, INCLUDING ACCESS COVERS.
- ⑯ .75"[19] HOLE BOLT PATTERN PROVIDED FOR SWITCH BOX MOUNTING. 42.75"[1086] X 29.88"[759] RECTANGLE BOLT PATTERN.
- ⑰ HV CONNECTION TO SWITCH MUST BE MADE PER PAGE TWO OF THIS DATA SHEET.
- ⑱ HEAT EXCHANGER WITH PROTECTIVE HIGH HAT COVER.

APPROX WEIGHT: 1350lbs, 612kg
 DIELECTRIC FLUID VOLUME: 29gal, 110L
 FINISH: ENAMEL, ASA 61, APPROX. RAL 7042
 SEALED TANK, SWITCH & CONTROL ENCLOSURE RATED NEMA 4/IP56
 ALL DIMENSIONS IN INCHES FOLLOWED BY [mm].