

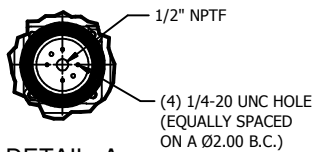

### HF ESP, POWERPLUS SERIES 56-70kW UNITS w/BOTTOM EXIT GROUND SWITCH

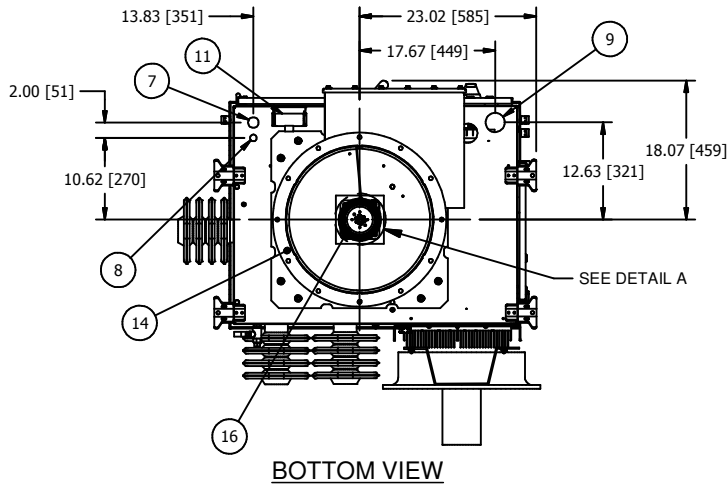
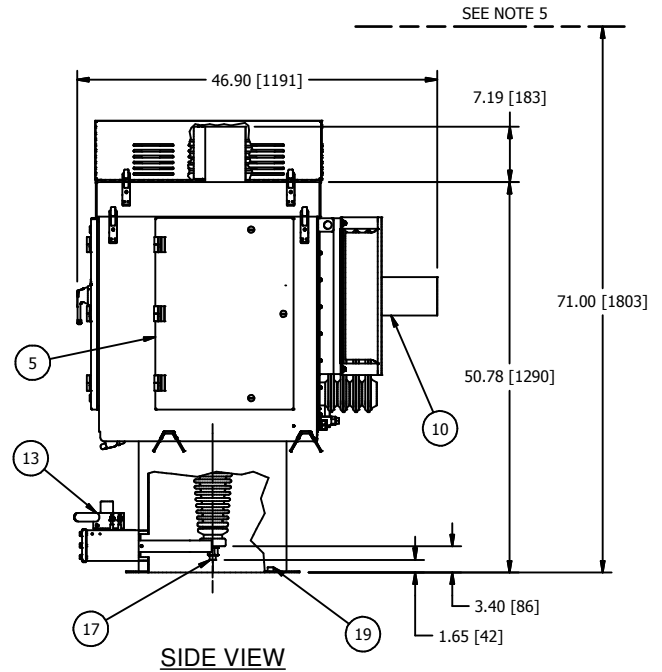
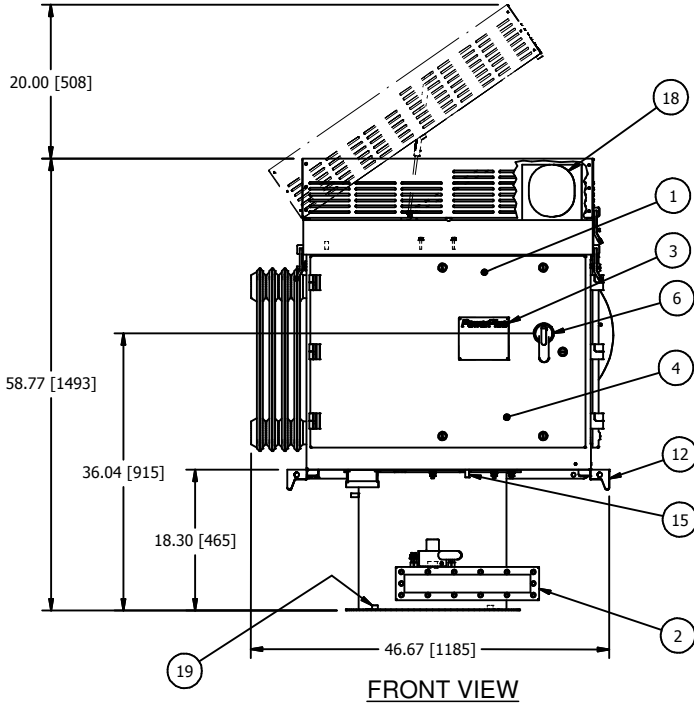

**DETAIL A**  
(HV OUTPUT CORONA RING DETAIL)

#### NOTES:

1. POWERPLUS AND SWITCH MUST BE MOUNTED ON LEVEL SURFACE OR SHIMMED TO WITHIN 1/8" [3.2] RISE PER 12" [305] RUN.
2. COLD ROOF MAY NEED TO BE REINFORCED TO ACCEPT THE WEIGHT OF THE POWERPLUS UNIT.
3. MAXIMUM ALLOWABLE DUCT INTERNAL TEMPERATURE: 122°F (50°C). MAXIMUM ALLOWABLE DUCT INTERNAL PRESSURE: 1 PSI (2.04" Hg). THE INSTALLER MUST USE AN ENTRANCE BUSHING IN ROOF TO MEET THESE SPECIFICATIONS.
4. POWERPLUS MUST BE GROUNDED TO THE COLD ROOF BY THE END USER. REFER TO DWG B125481 FOR GROUNDING DETAILS.
5. MINIMUM CLEARANCE REQUIRED ABOVE FLOOR TO LIFT AND REMOVE THE T/R RIG. CLEARANCE DOES NOT INCLUDE RIGGING HEIGHT.

APPROX. WEIGHT WITH GROUND SWITCH: 1100bs (499kg).  
DIELECTRIC FLUID VOLUME: 29gal (110L).  
FINISH: ENAMEL, ASA 61, APPROX. RAL 7042.  
TANK AND CONTROL ENCLOSURE RATED NEMA 4/IP56.

- 1 POWERPLUS UNIT
- 2 ROUND BOTTOM EXIT GROUND SWITCH.
- 3 RATINGS NAMEPLATE, ALUMINUM PHOTO ETCHED.
- 4 SWITCHGEAR AND CONTROL SECTION WITH HINGED DOOR. ALLOW 37" [940] OF CLEARANCE FROM THIS FACE FOR DOOR SWING.
- 5 POWER ELECTRONICS SECTION WITH HINGED DOOR. ALLOW 19" [483] OF CLEARANCE FROM THIS FACE FOR DOOR SWING.
- 6 INPUT CIRCUIT BREAKER SWITCH HANDLE WITH INTERLOCK PROVISION INSIDE. FOR ACCEPTABLE INTERLOCKS SEE DWG A105811.
- 7 1" [25.4] DIA. CONDUIT HOLE FOR 120V CONTROL WIRING.
- 8 1/2" [12.7] DIA. CONDUIT HOLE FOR LOW VOLTAGE COMMUNICATION AND OPTIONAL TRANSDUCER CONDUIT.
- 9 2" [51] DIA. CONDUIT HOLE FOR 3 PHASE POWER AND GROUND.
- 10 COOLING FAN FOR IGBT HEATSINK ASSEMBLY.
- 11 EZ SCOPE PORT WITH RJ45 SOCKET FOR KEYPAD DISPLAY CONNECTION AND BNC CONNECTORS FOR MAKING EXTERNAL kV AND mA MEASUREMENTS.
- 12 LIFTING HOOKS (4 PLACES).
- 13 H.V. SWITCH MECHANISM WITH VIEWING WINDOW AND INTERLOCK PROVISIONS. FOR INTERLOCK AND BOLT EXTENSION INFORMATION SEE DWG A105811.
- 14 BOTTOM EXIT DUCT FLANGE, 22.63" [575] O.D. X 19.00" [483] I.D. WITH (12) 0.50" [12.7] DIA. HOLES EQUALLY SPACED ON A 21.44" [545] DIA. B.C. (GASKET NOT INCLUDED).
- 15 S.S. GROUND CABLE TO GROUND EACH SECTION, INCLUDING ACCESS COVERS.
- 16 HIGH VOLTAGE SEMI-OUTDOOR BUSHING, SEE DETAIL 'A' FOR DETAILS.
- 17 OPTIONAL METRIC ADAPTER FOR H.V. BUSHING CONNECTION. CONVERTS 1/2" NPT TO M20-1.5. SEE DWG A117570.
- 18 HEAT EXCHANGER WITH PROTECTIVE HIGH HAT COVER. COVER IS HINGED TO ALLOW ACCESS TO CLEAN HEAT EXCHANGER, AND IS REQUIRED ON OUTDOOR UNITS (OPTION FOR INDOOR UNITS).
- 19 EQUIPMENT SAFETY GROUND TERMINATION, 3/8-16 GROUND BOSS.

DATA SHEET: ESP56-70RD-G

REVISION DATE: 01/17/11

APPROVED BY: HH

ALL DIMENSIONS IN INCHES [mm]