

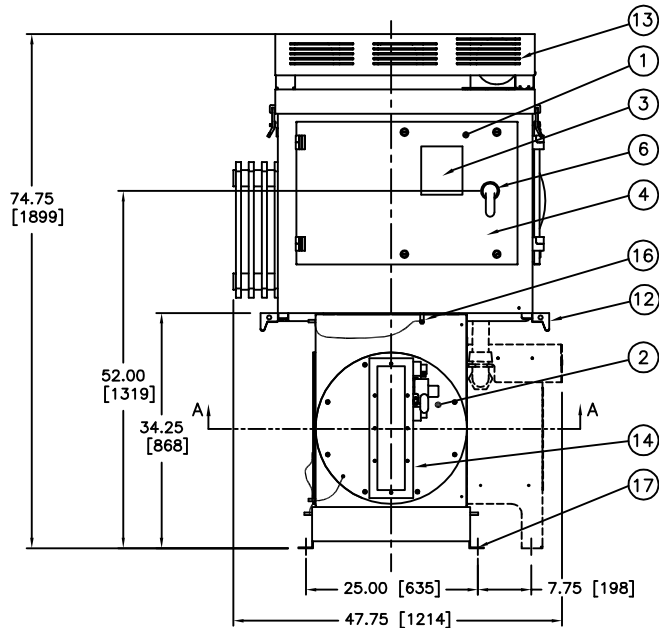

**HF ESP, POWER PLUS SERIES
56 & 70 kW WITH 3 PORT SIDE EXIT GROUND SWITCH**

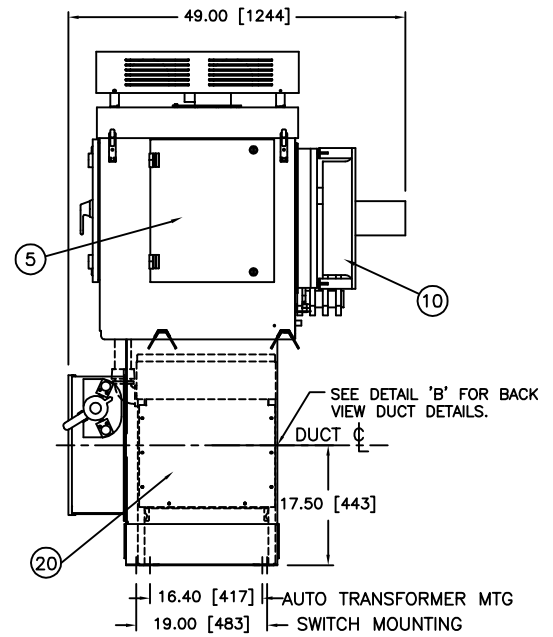

FRONT VIEW



SIDE VIEW

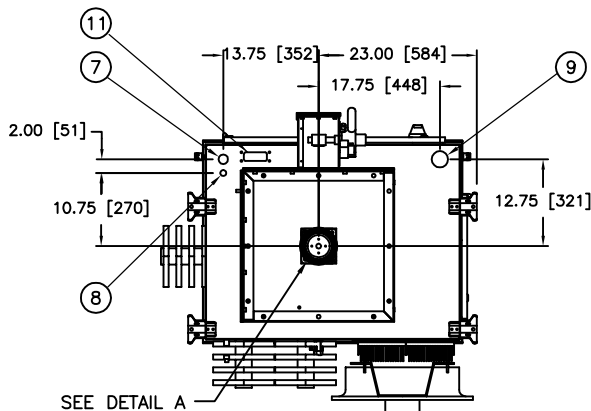

SECTION A-A

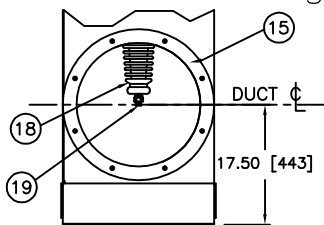

DETAIL B
BACK VIEW OF SWITCH
DUCT AND BUSHING DETAIL

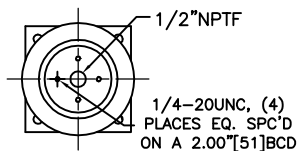

DETAIL A
HV OUTPUT
CORONA RING DETAIL

- ① POWER PLUS UNIT.
- ② 3 PORT SIDE EXIT GROUND SWITCH. SEE ESP-SQ-CONF FOR SWITCH CONFIGURATION OPTIONS.
- ③ RATINGS NAMEPLATE - ALUMINUM PHOTO ETCHED.
- ④ SWITCH GEAR AND CONTROL SECTION WITH HINGED DOOR. ALLOW 33"[838] OF CLEARANCE FROM THIS FACE FOR DOOR SWING.
- ⑤ POWER ELECTRONICS SECTION WITH HINGED DOOR. ALLOW 19"[483] OF CLEARANCE FROM THIS FACE FOR DOOR SWING.
- ⑥ INPUT CIRCUIT BREAKER SWITCH HANDLE WITH INTERLOCK PROVISION INSIDE. FOR ACCEPTABLE INTERLOCK SEE DWG A105811.
- ⑦ 1"[25.4] DIA CONDUIT HOLE FOR 120V CONTROL WIRING.
- ⑧ 1/2"[12.7] DIA CONDUIT HOLE FOR LOW VOLTAGE TRANSDUCER AND COMMUNICATION LINK CONDUIT.
- ⑨ 2"[51] DIA CONDUIT HOLE FOR 3 PH POWER AND GROUND.
- ⑩ COOLING FAN FOR IGBT HEATSINK ASSEMBLY.
- ⑪ EZ SCOPE PORT WITH RJ45 SOCKET FOR GVC DISPLAY CONNECTION AND BNC CONNECTORS FOR MAKING EXTERNAL kV AND mA MEASUREMENTS.
- ⑫ LIFTING HOOKS (4 PLACES).
- ⑬ HEAT EXCHANGER WITH PROTECTIVE HIGH HAT COVER. COVER IS HINGED TO ALLOW ACCESS TO CLEAN HEAT EXCHANGER.
- ⑭ H.V SWITCH MECHANISM WITH VIEWING WINDOW AND INTERLOCK PROVISIONS. FOR INTERLOCK AND BOLT EXTENSION INFO SEE DWG A105811.
- ⑮ SIDE EXIT DUCT MOUNTING PROVISION WITH 22"[558] O.D. COVER PLATE. INCLUDES GASKETS AND 3/8-16 HARDWARE 8 PLACES ON A 20"[508] DIA B.C. WITH 18"[457] DIA DUCT OPENING.
- ⑯ SS GROUND CABLE TO GROUND EACH SECTION, INCLUDING ACCESS COVERS.
- ⑰ .69"[17.5] HOLE BOLT PATTERN PROVIDED FOR SWITCH BOX MOUNTING. 25.00"[635] X 19.00"[482] BOLT PATTERN.
- ⑱ HIGH VOLTAGE SEMI-OUTDOOR BUSHING, SEE DETAIL A.
- ⑲ OPTIONAL METRIC ADAPTER FOR H.V. BUSHING CONNECTION. CONVERTS 1/2 NPT TO M20-1.5. SEE DWG A117570.
- ⑳ OPTIONAL AUTO TRANSFORMER MOUNTED IN A NEMA 3R JUNCTION BOX. NOT SHOWN IN BOTTOM VIEW.

NOTES:

1. POWERPLUS AND SWITCH MUST BE MOUNTED ON A LEVEL SURFACE OR SHIMED TO WITHIN 1/8"[3.2] RISE PER 12"[305] RUN.
2. COLD ROOF MAY NEED TO BE REINFORCED TO ACCEPT THE WEIGHT OF THE POWER PLUS UNIT.
3. MAXIMUM ALLOWABLE DUCT INTERNAL TEMPERATURE: 122°F (50°C). MAXIMUM ALLOWABLE DUCT INTERNAL PRESSURE: 1 PSI (2.04"Hg). THE INSTALLER MUST USE AN ENTRANCE BUSHING IN ROOF TO MEET THESE SPECIFICATIONS.
4. POWERPLUS MUST BE GROUNDED TO THE COLD ROOF BY THE END USER. REFER TO DWG B125481 FOR GROUNDING DETAILS.

APPROX WEIGHT WITH GND SWITCH: 1100LBS, 499KG
 APPROX WEIGHT WITH GND SWITCH AND AUTO TRANS: 1400LBS, 635KG
 DIELECTRIC FLUID VOLUME: 29gal, 110L
 FINISH: ENAMEL, ASA 61, APPROX. RAL 7042
 TANK AND CONTROL ENCLOSURE RATED NEMA 4/IP56
 ALL DIMENSIONS IN INCHES FOLLOWED BY [mm]

DATA SHEET: ESP56-70SQ-C
 REVISION DATE: 1/22/08
 APPROVED BY: HH