

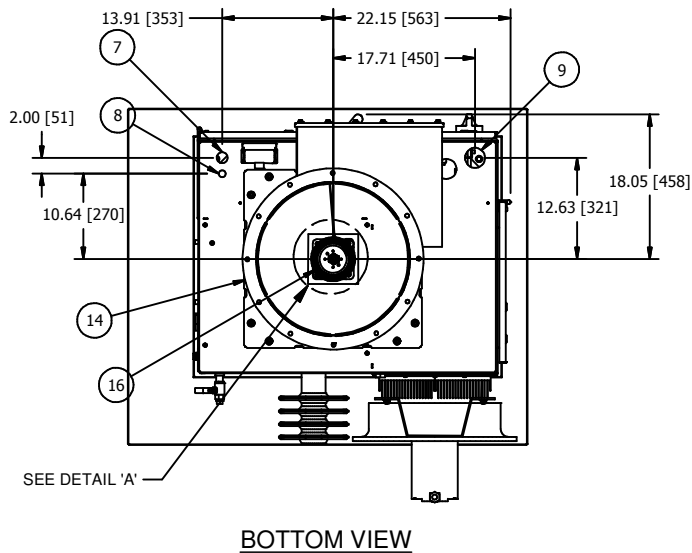

HF ESP, POWERPLUS SERIES 28-35kW UNITS w/BOTTOM EXIT GROUND SWITCH

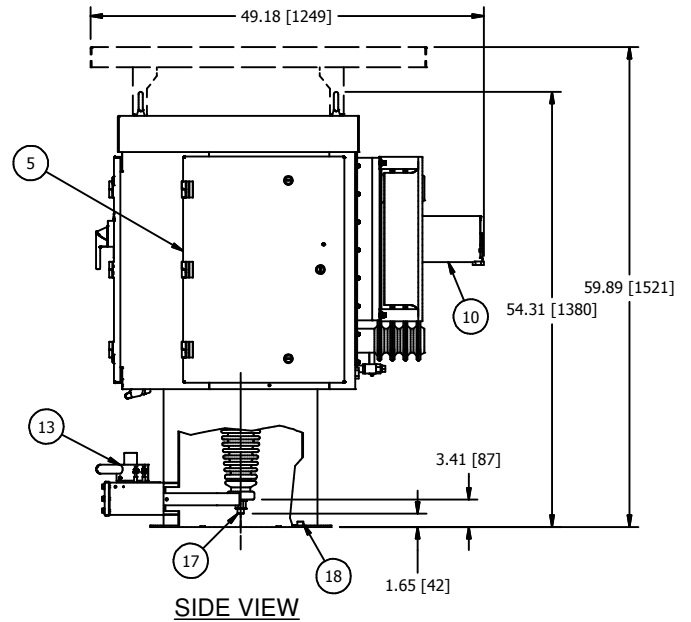

SEE DETAIL 'A'

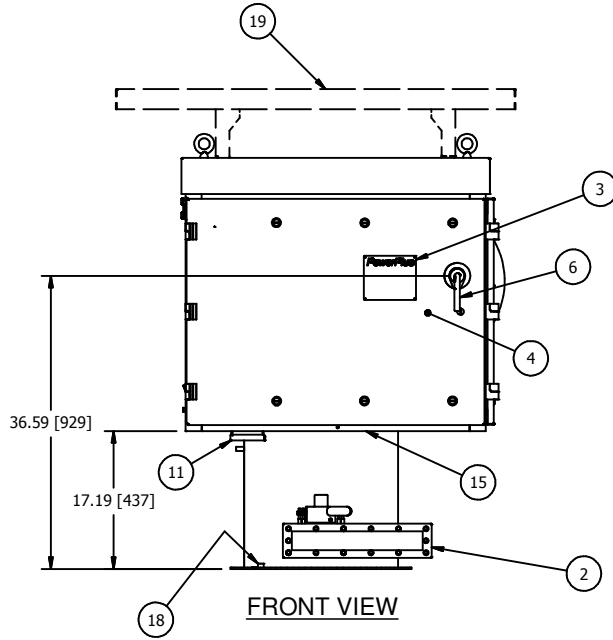
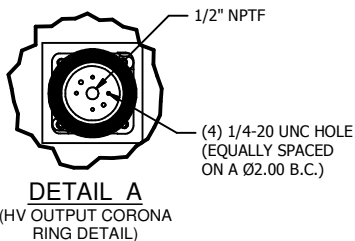

NOTES:

- POWERPLUS AND SWITCH MUST BE MOUNTED ON LEVEL SURFACE OR SHIMMED TO WITHIN 1/8" [3.2] RISE PER 12" [305] RUN.
- COLD ROOF MAY NEED TO BE REINFORCED TO ACCEPT THE WEIGHT OF THE POWERPLUS UNIT.
- MAXIMUM ALLOWABLE DUCT INTERNAL TEMPERATURE: 122°F (50°C). MAXIMUM ALLOWABLE DUCT INTERNAL PRESSURE: 1 PSI (2.04" Hg). THE INSTALLER MUST USE AN ENTRANCE BUSHING IN ROOF TO MEET THESE SPECIFICATIONS.
- POWERPLUS MUST BE GROUNDED TO THE COLD ROOF BY THE END USER. REFER TO DWG B125481 FOR GROUNDING DETAILS.
- MINIMUM CLEARANCE REQUIRED ABOVE FLOOR TO LIFT AND REMOVE THE T/R RIG IS 71". CLEARANCE DOES NOT INCLUDE RIGGING HEIGHT.

APPROX. WEIGHT WITH GROUND SWITCH: 1000bs (454kg).
DIELECTRIC FLUID VOLUME: 29gal (110L).
FINISH: ENAMEL, ASA 61, APPROX. RAL 7042.
TANK AND CONTROL ENCLOSURE RATED NEMA 4/IP56.

- POWERPLUS UNIT
- ROUND BOTTOM EXIT GROUND SWITCH.
- RATINGS NAMEPLATE, ALUMINUM PHOTO ETCHED.
- SWITCHGEAR AND CONTROL SECTION WITH HINGED DOOR. ALLOW 37" [940] OF CLEARANCE FROM THIS FACE FOR DOOR SWING.
- POWER ELECTRONICS SECTION WITH HINGED DOOR. ALLOW 19" [483] OF CLEARANCE FROM THIS FACE FOR DOOR SWING.
- INPUT CIRCUIT BREAKER SWITCH HANDLE WITH INTERLOCK PROVISION INSIDE. FOR ACCEPTABLE INTERLOCKS SEE DWG C140616.
- 1" [25.4] DIA. CONDUIT HOLE FOR 120V CONTROL WIRING.
- 1/2" [12.7] DIA. CONDUIT HOLE FOR LOW VOLTAGE COMMUNICATION AND OPTIONAL TRANSDUCER CONDUIT.
- 2" [51] DIA. CONDUIT HOLE FOR 3 PHASE POWER AND GROUND.
- COOLING FAN FOR IGBT HEATSINK ASSEMBLY.
- EZ SCOPE PORT WITH RJ45 SOCKET FOR KEYPAD DISPLAY CONNECTION AND BNC CONNECTORS FOR MAKING EXTERNAL kV AND mA MEASUREMENTS.
- LIFTING EYES (4 PLACES).
- H.V. SWITCH MECHANISM WITH VIEWING WINDOW AND INTERLOCK PROVISIONS. FOR INTERLOCK AND BOLT EXTENSION INFORMATION SEE DWG A105811.
- BOTTOM EXIT DUCT FLANGE, 22.63" [575] O.D. X 19.00" [483] I.D. WITH (12) 0.50" [12.7] DIA. HOLES EQUALLY SPACED ON A 21.44" [545] DIA. BOLT CIRCLE, (GASKET NOT INCLUDED).
- S.S. GROUND CABLE TO GROUND EACH SECTION, INCLUDING ACCESS COVERS.
- HIGH VOLTAGE SEMI-OUTDOOR BUSHING, SEE DETAIL 'A' FOR DETAILS.
- OPTIONAL METRIC ADAPTER FOR H.V. BUSHING CONNECTION. CONVERTS 1/2" NPT TO M20-1.5. SEE DWG A117570.
- EQUIPMENT SAFETY GROUND TERMINATION, 3/8-16 GROUND BOSS.
- OPTIONAL SUN SHIELD MUST BE SHIPPED SEPARATELY AND INSTALLED IN THE FIELD.

ALL DIMENSIONS IN INCHES [mm]

DATA SHEET: ESP28-35RD-C
REVISION DATE: 10/14/15
APPROVED BY: HH